

Cyclone Direct Acting Solenoid Valves

Catalog VAL-CYC-E

aerospace
climate control
electromechanical
filtration
fluid & gas handling
hydraulics
pneumatics
process control
sealing & shielding



ENGINEERING YOUR SUCCESS.

 **WARNING**

FAILURE OR IMPROPER SELECTION OR IMPROPER USE OF THE PRODUCTS AND/OR SYSTEMS DESCRIBED HEREIN OR RELATED ITEMS CAN CAUSE DEATH, PERSONAL INJURY AND PROPERTY DAMAGE.

This document and other information from Parker Hannifin Corporation, its subsidiaries and authorized distributors provide product and/or system options for further investigation by users having technical expertise. It is important that you analyze all aspects of your application including consequences of any failure, and review the information concerning the product or system in the current product catalog. Due to the variety of operating conditions and applications for these products or systems, the user, through its own analysis and testing, is solely responsible for making the final selection of the products and systems and assuring that all performance, safety and warning requirements of the application are met.

The products described herein, including without limitation, product features, specifications, designs, availability and pricing, are subject to change by Parker Hannifin Corporation and its subsidiaries at any time without notice.

Offer of Sale

The items described in this document are hereby offered for sale by Parker Hannifin Corporation, its subsidiaries or its authorized distributors. This offer and its acceptance are governed by the provisions stated on the separate page of this document entitled "Offer of Sale".

© Copyright 2011 Parker Hannifin Corporation. All Rights Reserved



Parker Hannifin Corporation
Pneumatic Division
Richland, Michigan
www.parker.com/pneumatic

Basic Valve Features2
Model Number Index3
Multi-Purpose Valve Functions3
Direct Acting Solenoid Valves
 2-Way Normally Open General4
 2-Way Normally Closed General.....4
 3-Way Normally Open General5
 3-Way Normally Closed Free Venting & Pipe Exhaust.....5
 3-Way Normally Closed Directional Control.....6
 3-Way Directional Control Multi-Purpose.....6
Dimensions & Technical Information.....7
Service Kits8
Offer of Sale9

- 2 & 3-Way, 2-Position.
- Cv = .02 to .73 depending on orifice structure and flow path.
- Inline or surface mounted.
- Used with inert liquids and gases. (Consult factory for compatibility.)
- 1/8 and 1/4 inch Ports.
- Standard class "F" coil (Class "H" optional) rated for continuous duty in a variety of voltages.
- Grommet or Conduit housings with 18 inch leads.
- Rotatable housings for ease of installation.
- NEMA 4 enclosures available.
- Copper shading ring standard.
- Self compensating seals increase valve life.
- Approved to be CE marked.
- CSA Standard.
- Stainless steel body (standard) Brass (optional).
- Proven extended life reliability.

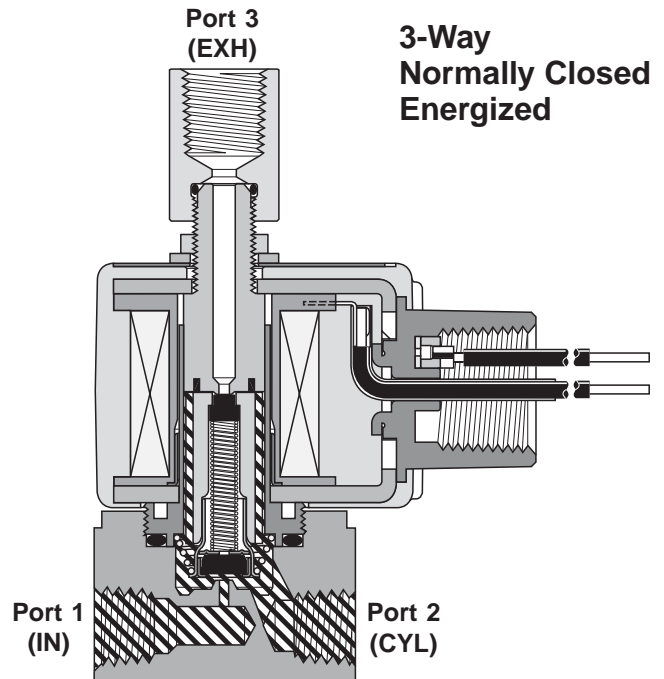
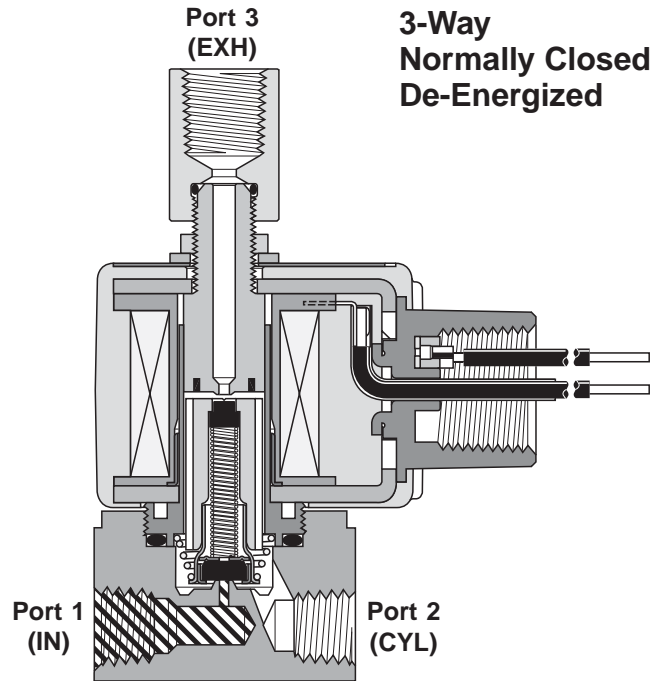

Basic Series 7	Housing Type 5	Valve Type 3	Port Size 1	Orifice 2	Options 0	Seals 1	Coil Class & Hertz 1	Voltage 5	Design Level B
Basic Series 7	Housing Type 4 Conduit 5 Grommet		Port Size 0 1/8" S.S. 1 1/4" S.S. 2 1/8" Brass 3 1/4" Brass		Options 0 None (Std)	Seals 1 Nitrile (Buna) 2 Fluorocarbon		Voltage 2 12 VDC 3 24 VDC 5 120 VAC 6 240 VAC	
		Valve Type 0 2-Way Normally Open 1 2-Way Normally Closed 2 3-Way Normally Open 3 3-Way Normally Closed, Free Vent 4 3-Way Normally Closed, Piped Exhaust 5 3-Way Multi-Purpose 6 3-Way Directional Control		Orifice Diameter Body Stop 0 1/32" 1/32" 1 3/64" 3/64" 1* 1/16" 3/64" 2 3/64" 1/16" 3 1/16" 1/16" 4 3/32" 3/32" 5 1/8" 1/16" 6 1/8" 3/32" 7 5/32" 3/32" 8 3/16" 3/32" 9 7/32" 3/32"			Coil Class Class Hertz 1 F 60 2 F DC 9 H 60 †† 0 H DC ††		

† Used on Valve Type 2, Normally Open, 3-Way valves only.

†† All Valves with Class "H" Coils Contain Fluorocarbon Seals.

EXAMPLE: Solenoid Valve #75312 0115 B

75 Valve w/ Grommet Housing	3 3-Way Normally Closed Free Venting	1 1/4" Ports	2 3/64" body (orifice dia.) 1/16" stop (orifice dia.)	0 Standard (No options)	1 Buna N Seals	1 Class "F" Coil 60 Hz	5 120 Volts	B
---	--	---------------------------	--	--------------------------------------	-----------------------------	-------------------------------------	--------------------------	----------

Multi-Purpose Valve Functions

The basic 3-Way multi-purpose valve can be field converted to perform as any one of the following:

1. 2-Way Normally Open – Plug Port 1 / use Port 2 as the inlet.

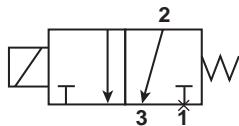

2. 2-Way Normally Closed – Plug Port 3 / use Port 2 as the inlet.

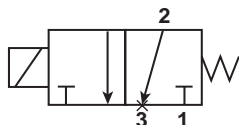

3. 3-Way Normally Open – Use Port 3 as the inlet / use Port 1 as the exhaust / use Port 2 as the working line.

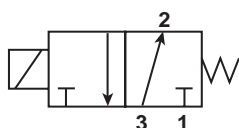

4. 3-Way Normally Closed – Use Port 1 as the inlet / use Port 3 as the exhaust / use Port 2 as the working line.

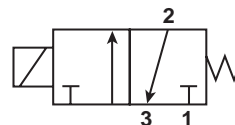

5. Directional Control Valve – Use Port 2 as inlet / use Port 3 as the normally open working line / use Port 1 as the normally closed working line.

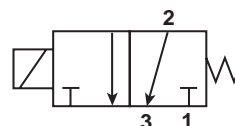

6. Selector Valve – Use Ports 1 and 3 as the inlets / use Port 2 as the working line.

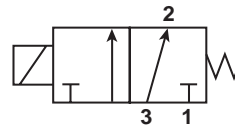

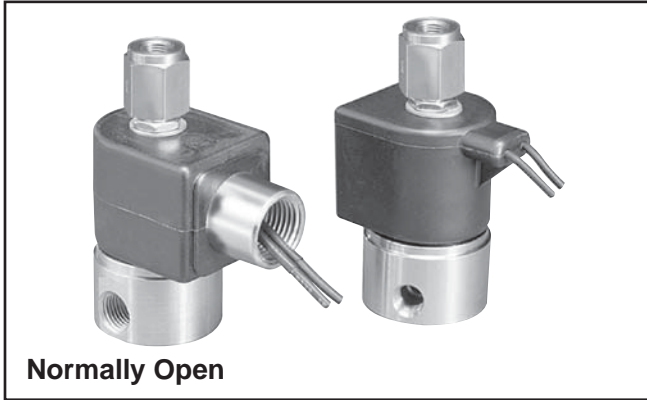

Application

These valves provide on-off control of inert liquids and gases.

Mounting

These valves may be oriented in any position and can be mounted inline or surface mounted using the two #10-32 x 3/8" holes provided in the bottom of the valve body. The solenoid housing rotates for ease of electrical connections.

Operation

De-energized position – Flow is permitted from inlet Port 2 out Port 3 at the top of the valve.

Energized position – Pressure at inlet Port 2 is blocked, shutting off flow to Port 3.

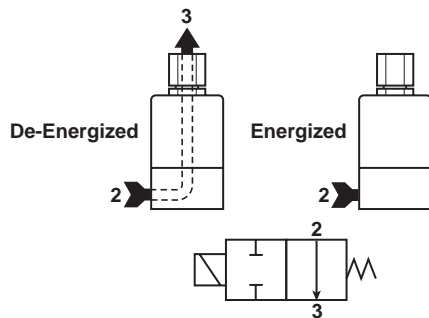

Model Selection (Listed for 120V/60Hz.)*

†M.O.P.D. (PSIG)	Orifice / Cv		Conduit Housing	
	AC & DC	Stop	Cv	1/8" Ports
300	1/32"	.02	74000 0115 B	74010 0115 B
200	3/64"	.06	74001 0115 B	74011 0115 B
150	1/16"	.12	74002 0115 B	74012 0115 B
125	3/32"	.21	74004 0115 B	74014 0115 B

Note: For GROMMET HOUSING change the second digit in the model number from 4 to 5.

* See Valve Model Number System for other voltages.

† (Maximum Operating Pressure Differential)

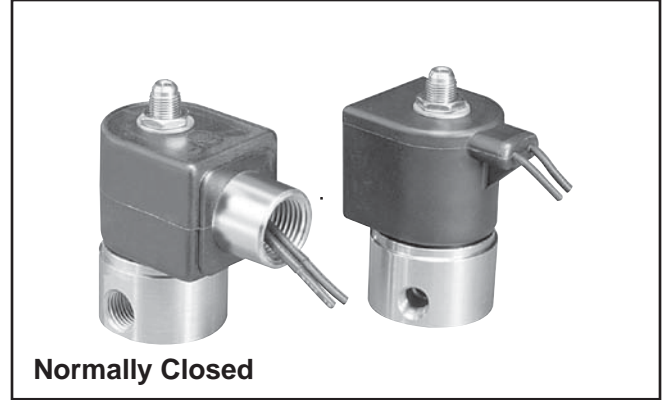

Application

These valves provide on-off control of inert liquids and gases.

Mounting

These valves may be oriented in any position and can be mounted inline or surface mounted using the two #10-32 x 3/8" holes provided in the bottom of the valve body. The solenoid housing rotates for ease of electrical connections.

Operation

De-energized position – Pressure at inlet Port 2 is blocked, preventing flow to Port 1.

Energized position – Flow is permitted from inlet Port 2 through the valve body to Port 1.

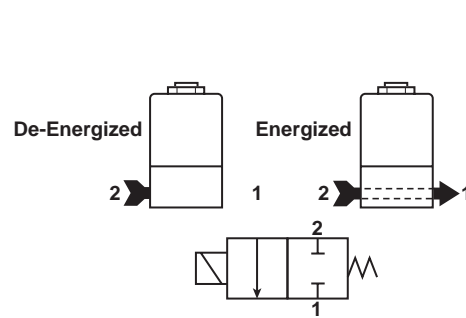

Model Selection (Listed for 120V/60Hz.)*

†M.O.P.D. (PSIG)	Orifice / Cv		Conduit Housing		
	AC	DC	Body	Cv	1/8" Ports
500	500	1/32"	.02	74100 0115 B	74110 0115 B
250	250	3/64"	.06	74101 0115 B	74111 0115 B
200	200	1/16"	.11	74103 0115 B	74113 0115 B
125	125	3/32"	.21	74104 0115 B	74114 0115 B
100	100	1/8"	.34	74105 0115 B	74115 0115 B
75	50	5/32"	.37	74107 0115 B	74117 0115 B
50	25	3/16"	.52	74108 0115 B	74118 0115 B
25	10	7/32"	.62	74109 0115 B	74119 0115 B

Note: For GROMMET HOUSING change the second digit in the model number from 4 to 5.

* See Valve Model Number System for other voltages.

† (Maximum Operating Pressure Differential)

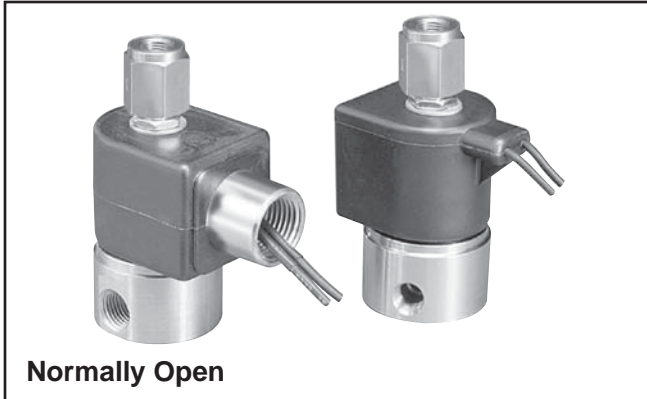

Application

These valves are used to provide pilot signals for larger valves, operate single acting cylinders, or are used in pairs to operate double acting cylinders.

Mounting

These valves may be oriented in any position and can be mounted inline or surface mounted using the two #10-32 x 3/8" holes provided in the bottom of the valve body. The solenoid housing rotates for ease of electrical connections.

Operation

De-energized position – Flow is permitted from inlet Port 3 at the top of the valve out Port 2 in the valve body. Exhaust Port 1 is blocked.

Energized position – Inlet Port 3 at the top of the valve is blocked. Port 2 is exhausted through the valve body to Port 1.

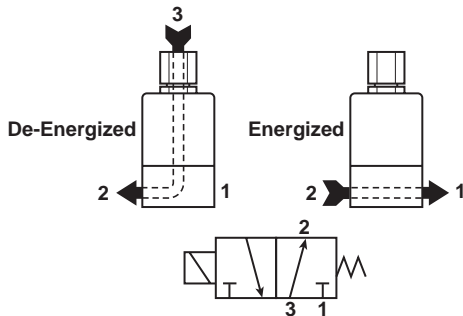

Model Selection (Listed for 120V/60Hz.)*

†M.O.P.D. (PSIG)	Orifice / Cv				Conduit Housing	
	Body	Cv	Stop	Cv	1/8" Ports	1/4" Ports
200	1/32"	.02	1/32"	.02	74200 0115 B	74210 0115 B
150	1/16"	.11	3/64"	.06	74201 0115 B	74211 0115 B
100	1/8"	.34	1/16"	.10	74205 0115 B	74215 0115 B
75	1/8"	.34	3/32"	.18	74206 0115 B	74216 0115 B
50	5/32"	.37	3/32"	.18	74207 0115 B	74217 0115 B
25	3/16"	.52	3/32"	.18	74208 0115 B	74218 0115 B
10	7/32"	.62	3/32"	.18	74209 0115 B	74219 0115 B

Note: For GROMMET HOUSING change the second digit in the model number from 4 to 5.

* See Valve Model Number System for other voltages.

† (Maximum Operating Pressure Differential)

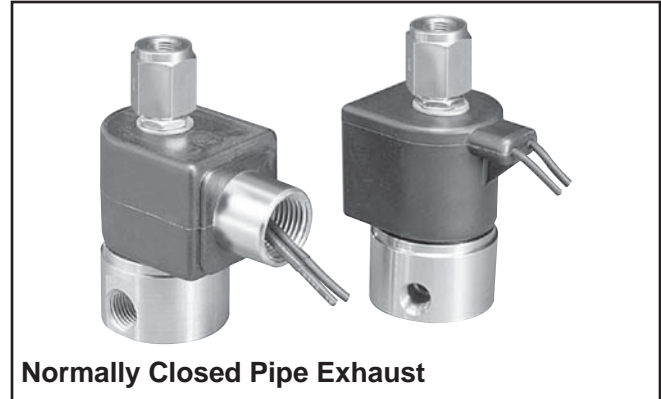

Application

These valves operate similar to 3-Way normally closed, free venting, but are used where the exhaust needs to be piped away from the valve.

Mounting

These valves may be oriented in any position and can be mounted inline or surface mounted using the two #10-32 x 3/8" holes provided in the bottom of the valve body. The solenoid housing rotates for ease of

Operation

De-energized position – Inlet Port 1 is blocked. Port 2 is exhausted out the top of the valve to Port 3.

Energized position – Flow is permitted from inlet Port 1 through the valve body to Port 2. Exhaust Port 3 at the top of the valve is blocked.

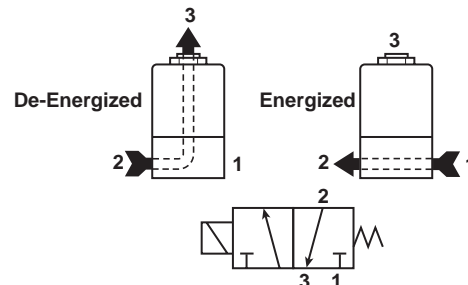

Model Selection (Listed for 120V/60Hz.)*

†M.O.P.D. (PSIG)	Orifice / Cv				Conduit Housing	
	Body	Cv	Stop	Cv	1/8" Ports	1/4" Ports
2	1/32"	.02	1/32"	.02	74400 0115 B	74410 0115 B
175	3/64"	.06	1/16"	.12	74402 0115 B	74412 0115 B
125	1/16"	.10	1/16"	.12	74403 0115 B	74413 0115 B
90	3/32"	.20	3/32"	.21	74404 0115 B	74414 0115 B
65	1/8"	.32	3/32"	.21	74406 0115 B	74416 0115 B
40	5/32"	.42	3/32"	.21	74407 0115 B	74417 0115 B
20	3/16"	.52	3/32"	.21	74408 0115 B	74418 0115 B
10	7/32"	.73	3/32"	.21	74409 0115 B	74419 0115 B

Note: For GROMMET HOUSING change the second digit in the model number from 4 to 5.

* See Valve Model Number System for other voltages.

† (Maximum Operating Pressure Differential)

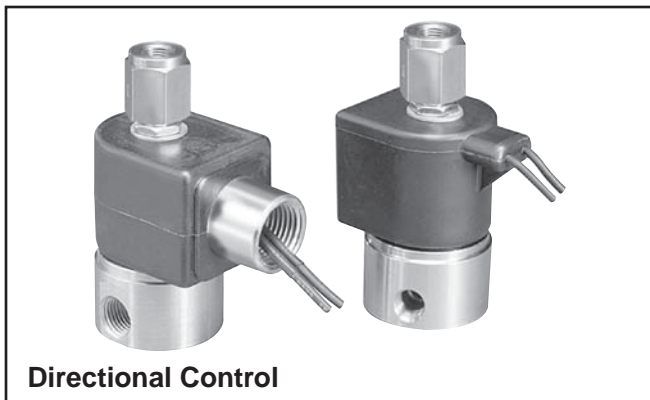

Application

These valves are used to select the directional flow of inert liquids and gases out either of two working ports.

Mounting

These valves may be oriented in any position and can be mounted inline or surface mounted using the two #10-32 x 3/8" holes provided in the bottom of the valve body. The solenoid housing rotates for ease of electrical connections.

Operation

De-energized position – Flow is permitted from inlet Port 2 in the valve body out Port 3 at the top of the valve. Port 1 in the valve body is blocked.

Energized position - Flow is permitted from inlet Port 2 through the valve body to Port 1. Port 3 at the top of the valve is blocked.

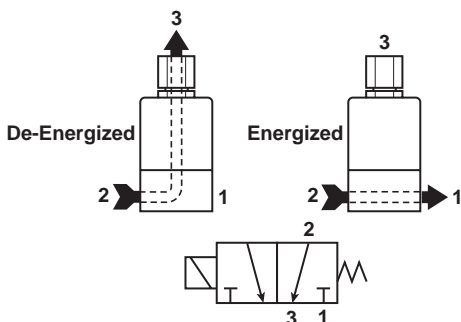

Model Selection (Listed for 120V/60Hz.)*

†M.O.P.D. (PSIG)	Orifice / Cv				Conduit Housing	
	Body	Cv	Stop	Cv	1/8" Ports	1/4" Ports
300	1/32"	.02	1/32"	.02	74600 0115 B	74610 0115 B
200	3/64"	.06	3/64"	.06	74601 0115 B	74611 0115 B
150	1/16"	.11	1/16"	.12	74603 0115 B	74613 0115 B
125	3/32"	.21	3/32"	.21	74604 0115 B	74614 0115 B
100	1/8"	.34	3/32"	.21	74606 0115 B	74616 0115 B
75	5/32"	.37	3/32"	.21	74607 0115 B	74617 0115 B
50	3/16"	.52	3/32"	.21	74608 0115 B	74618 0115 B

Note: For GROMMET HOUSING change the second digit in the model number from 4 to 5.

* See Valve Model Number System for other voltages.

† (Maximum Operating Pressure Differential)

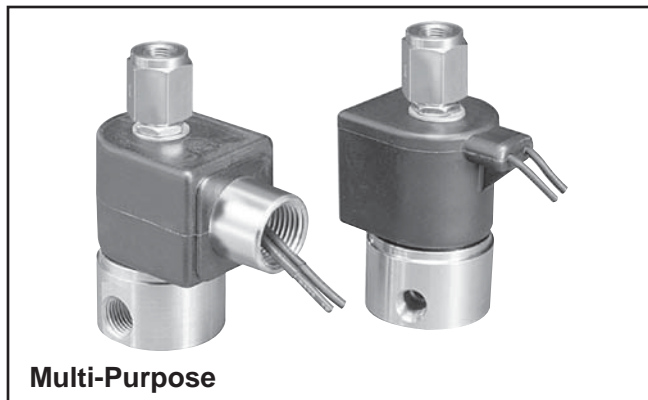

Application

These valves may be used in six different ways (see description on page 3). In the 2-Way configuration, valves provide on-off control of inert liquids and gases. In the 3-Way configuration, valves provide pilot signals to larger valves, operate single acting cylinders, or are used in pairs to operate double acting cylinders.

Mounting

These valves may be oriented in any position and can be mounted inline or surface mounted using the two #10-32 x 3/8" holes provided in the bottom of the valve body. The solenoid housing rotates for ease of electrical connections.

Operation

De-energized position – Port 2 in the valve body is connected to Port 3 at the top of the valve. Port 1 is blocked.

Energized position – Port 2 is connected through the valve body to Port 1. Port 3 at the top of the valve is blocked.

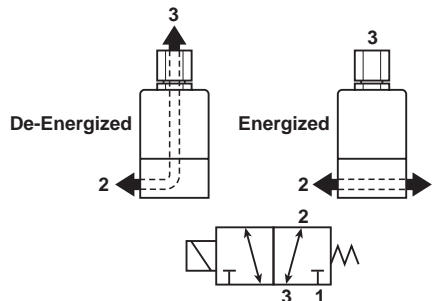

Model Selection (Listed for 120V/60Hz.)*

†M.O.P.D. (PSIG)	Orifice / Cv				Conduit Housing	
	Body	Cv	Stop	Cv	1/8" Ports	1/4" Ports
250	1/32"	.02	1/32"	.02	74500 0115 B	74510 0115 B
150	3/64"	.06	3/64"	.06	74501 0115 B	74511 0115 B
100	1/16"	.10	1/16"	.10	74503 0115 B	74513 0115 B
75	3/32"	.20	3/32"	.18	74504 0115 B	74514 0115 B
50	1/8"	.32	3/32"	.18	74506 0115 B	74516 0115 B
30	5/32"	.42	3/32"	.18	74507 0115 B	74517 0115 B
10	3/16"	.52	3/32"	.18	74508 0115 B	74518 0115 B
10	7/32"	.73	3/32"	.18	74509 0115 B	74519 0115 B

Note: For GROMMET HOUSING change the second digit in the model number from 4 to 5.

* See Valve Model Number System for other voltages.

† (Maximum Operating Pressure Differential)

Operating Pressure

Vacuum to the Maximum Operating Pressure Differential (M.O.P.D.) assigned to the orifice structure chosen from valve selection chart. M.O.P.D. is the maximum allowable difference between pressures recorded at any two working ports of the valve. If the M.O.P.D. is not known, regard the M.O.P.D. as the supply pressure.

Maximum Pressure: up to 500 PSIG

Temperature Range (Ambient)

Continuous Duty

Class "F" Coils -7°C to 52°C (20°F to 125°F)
 Class "H" Coils, Fluorocarbon Seals -7°C to 82°C (20°F to 180°F)

Materials

- Body:** Stainless Steel Type 416F, Brass (optional)
- Internal Components:** Stainless Steel Type 302, 304 & 430F
- Shading Ring:** Copper
- Seals:** Buna N (standard); Fluorocarbon (optional)
- Coil:** Class "F" (standard), Class "H" (optional)
 Epoxy Encapsulated

Service Kits

In addition to the kits configurable from the matrix below, the following kits are also provided.

Kit Number	Description	Included Items
PS3901P	1/8" Connector Kit	A & K
PS3902P	1/4" Connector Kit	A & K
740007100B	Assembly Wrench	Not Shown

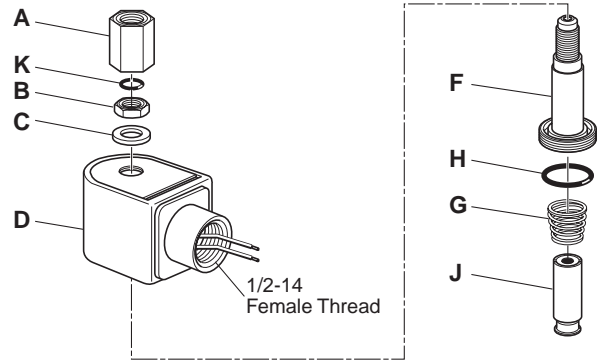

General Purpose

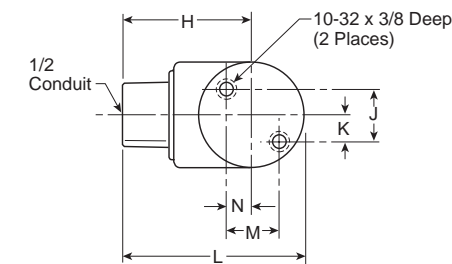
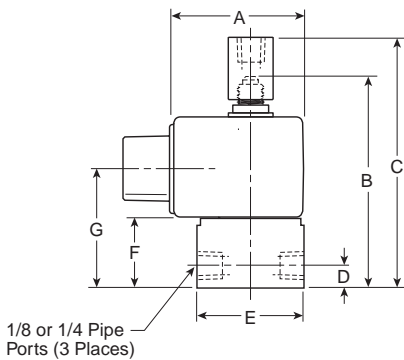

Dimensions:

	inches	mm
A	1.55	39
B	3.12	79
C	3.67	93
D	.34	9
E	1.63	41
F	1.06	27
G	1.83	46
H	1.95	50
J	.88	22
K	.44	11
L	2.76	70
M	.88	22
N	.44	11

Service Index Kit (Standard)

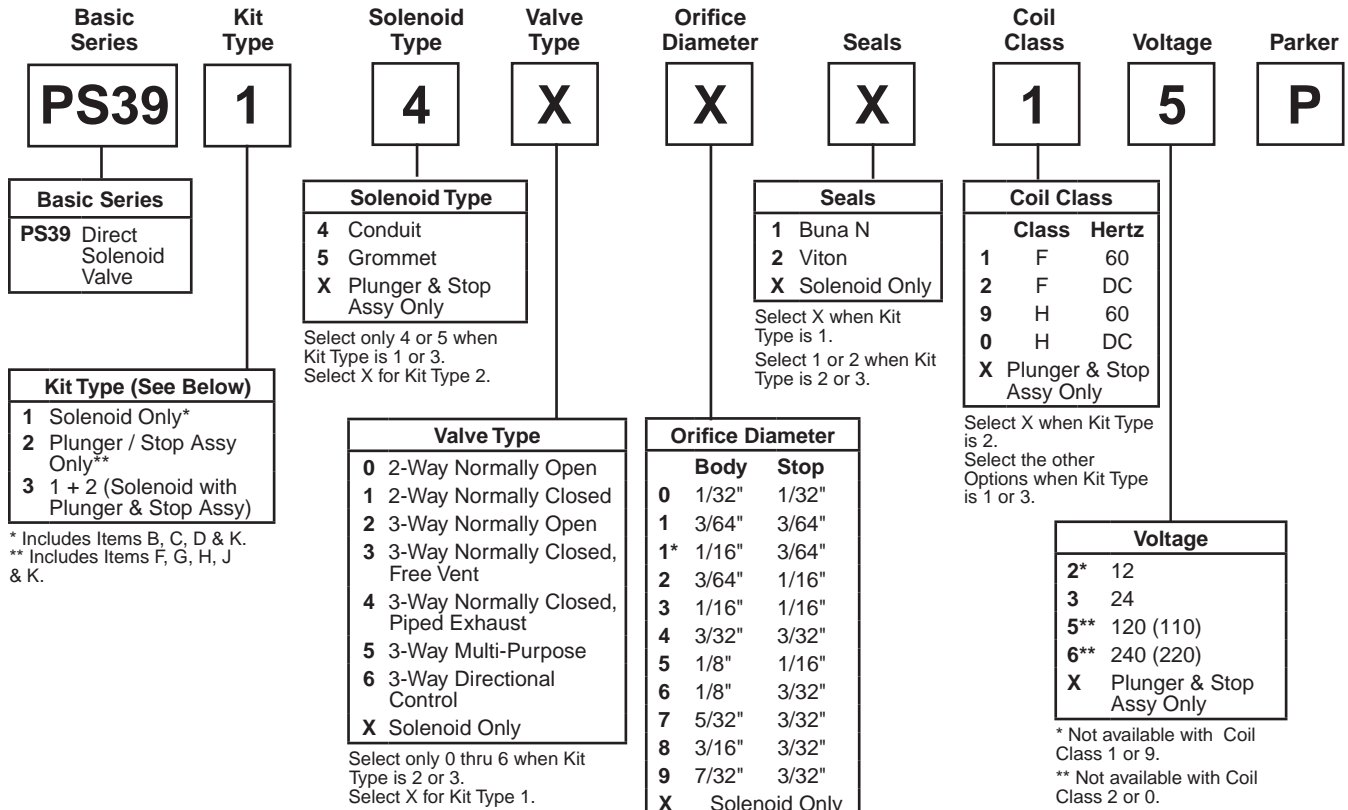

* Includes Items B, C, D & K.
 ** Includes Items F, G, H, J & K.

Engineering Level "B" valves can use Kit Types: 1, 2, or 3.
All other valves ONLY use Kit Type 3.

Example:
 For Valve Model Number 745030115:
The Only Kit Is PS393453115P

Example:
 For Valve Model Number 745030115B:
 The Solenoid Assy. No. Is PS3914XXX15P
 The Plunger Stop Assy. No. Is PS392X531XXP

* Used on Valve Type 2, Normally Open, 3-Way valves only.
 Select X when Kit Type is 1.
 Select 0 thru 9 when Kit Type is 2 or 3.

* Not available with Coil Class 1 or 9.
 ** Not available with Coil Class 2 or 0.
 Select X when Kit Type is 2.
 Select the other Options when Kit Type is 1 or 3.

Safety Guide For Selecting And Using Pneumatic Division Products And Related Accessories

WARNING:

FAILURE OR IMPROPER SELECTION OR IMPROPER USE OF PNEUMATIC DIVISION PRODUCTS, ASSEMBLIES OR RELATED ITEMS ("PRODUCTS") CAN CAUSE DEATH, PERSONAL INJURY, AND PROPERTY DAMAGE. POSSIBLE CONSEQUENCES OF FAILURE OR IMPROPER SELECTION OR IMPROPER USE OF THESE PRODUCTS INCLUDE BUT ARE NOT LIMITED TO:

- Unintended or mistimed cycling or motion of machine members or failure to cycle
- Work pieces or component parts being thrown off at high speeds.
- Failure of a device to function properly for example, failure to clamp or unclamp an associated item or device.
- Explosion
- Suddenly moving or falling objects.
- Release of toxic or otherwise injurious liquids or gasses.

Before selecting or using any of these Products, it is important that you read and follow the instructions below.

1. GENERAL INSTRUCTIONS

- 1.1. Scope:** This safety guide is designed to cover general guidelines on the installation, use, and maintenance of Pneumatic Division Valves, FRLs (Filters, Pressure Regulators, and Lubricators), Vacuum products and related accessory components.
- 1.2. Fail-Safe:** Valves, FRLs, Vacuum products and their related components can and do fail without warning for many reasons. Design all systems and equipment in a fail-safe mode, so that failure of associated valves, FRLs or Vacuum products will not endanger persons or property.
- 1.3. Relevant International Standards:** For a good guide to the application of a broad spectrum of pneumatic fluid power devices see: ISO 4414:1998, Pneumatic Fluid Power – General Rules Relating to Systems. See www.iso.org for ordering information.
- 1.4. Distribution:** Provide a copy of this safety guide to each person that is responsible for selection, installation, or use of Valves, FRLs or Vacuum products. Do not select, or use Parker valves, FRLs or vacuum products without thoroughly reading and understanding this safety guide as well as the specific Parker publications for the products considered or selected.
- 1.5. User Responsibility:** Due to the wide variety of operating conditions and applications for valves, FRLs, and vacuum products Parker and its distributors do not represent or warrant that any particular valve, FRL or vacuum product is suitable for any specific end use system. This safety guide does not analyze all technical parameters that must be considered in selecting a product. The user, through its own analysis and testing, is solely responsible for:
 - Making the final selection of the appropriate valve, FRL, Vacuum component, or accessory.
 - Assuring that all user's performance, endurance, maintenance, safety, and warning requirements are met and that the application presents no health or safety hazards.
 - Complying with all existing warning labels and / or providing all appropriate health and safety warnings on the equipment on which the valves, FRLs or Vacuum products are used; and,
 - Assuring compliance with all applicable government and industry standards.
- 1.6. Safety Devices:** Safety devices should not be removed, or defeated.
- 1.7. Warning Labels:** Warning labels should not be removed, painted over or otherwise obscured.
- 1.8. Additional Questions:** Call the appropriate Parker technical service department if you have any questions or require any additional information. See the Parker publication for the product being considered or used, or call 1-800-CPARKER, or go to www.parker.com, for telephone numbers of the appropriate technical service department.

2. PRODUCT SELECTION INSTRUCTIONS

- 2.1. Flow Rate:** The flow rate requirements of a system are frequently the primary consideration when designing any pneumatic system. System components need to be able to provide adequate flow and pressure for the desired application.
- 2.2. Pressure Rating:** Never exceed the rated pressure of a product. Consult product labeling, Pneumatic Division catalogs or the instruction sheets supplied for maximum pressure ratings.
- 2.3. Temperature Rating:** Never exceed the temperature rating of a product. Excessive heat can shorten the life expectancy of a product and result in complete product failure.
- 2.4. Environment:** Many environmental conditions can affect the integrity and suitability of a product for a given application. Pneumatic Division products are designed for use in general purpose industrial applications. If these products are to be used in unusual circumstances such as direct sunlight and/or corrosive or caustic environments, such use can shorten the useful life and lead to premature failure of a product.
- 2.5. Lubrication and Compressor Carryover:** Some modern synthetic oils can and will attack nitrile seals. If there is any possibility of synthetic oils or greases migrating into the pneumatic components check for compatibility with the seal materials used. Consult the factory or product literature for materials of construction.
- 2.6. Polycarbonate Bowls and Sight Glasses:** To avoid potential polycarbonate bowl failures:
 - Do not locate polycarbonate bowls or sight glasses in areas where they could be subject to direct sunlight, impact blow, or temperatures outside of the rated range.
 - Do not expose or clean polycarbonate bowls with detergents, chlorinated hydro-carbons, ketones, esters or certain alcohols.
 - Do not use polycarbonate bowls or sight glasses in air systems where compressors are lubricated with fire resistant fluids such as phosphate ester and di-ester lubricants.

2.7. Chemical Compatibility: For more information on plastic component chemical compatibility see Pneumatic Division technical bulletins Tec-3, Tec-4, and Tec-5

- 2.8. Product Rupture:** Product rupture can cause death, serious personal injury, and property damage.
- Do not connect pressure regulators or other Pneumatic Division products to bottled gas cylinders.
 - Do not exceed the maximum primary pressure rating of any pressure regulator or any system component.
 - Consult product labeling or product literature for pressure rating limitations.

3. PRODUCT ASSEMBLY AND INSTALLATION INSTRUCTIONS

- 3.1. Component Inspection:** Prior to assembly or installation a careful examination of the valves, FRLs or vacuum products must be performed. All components must be checked for correct style, size, and catalog number. DO NOT use any component that displays any signs of nonconformance.
- 3.2. Installation Instructions:** Parker published Installation Instructions must be followed for installation of Parker valves, FRLs and vacuum components. These instructions are provided with every Parker valve or FRL sold, or by calling 1-800-CPARKER, or at www.parker.com.
- 3.3. Air Supply:** The air supply or control medium supplied to Valves, FRLs and Vacuum components must be moisture-free if ambient temperature can drop below freezing

4. VALVE AND FRL MAINTENANCE AND REPLACEMENT INSTRUCTIONS

- 4.1. Maintenance:** Even with proper selection and installation, valve, FRL and vacuum products service life may be significantly reduced without a continuing maintenance program. The severity of the application, risk potential from a component failure, and experience with any known failures in the application or in similar applications should determine the frequency of inspections and the servicing or replacement of Pneumatic Division products so that products are replaced before any failure occurs. A maintenance program must be established and followed by the user and, at minimum, must include instructions 4.2 through 4.10.
- 4.2. Installation and Service Instructions:** Before attempting to service or replace any worn or damaged parts consult the appropriate Service Bulletin for the valve or FRL in question for the appropriate practices to service the unit in question. These Service and Installation Instructions are provided with every Parker valve and FRL sold, or are available by calling 1-800-CPARKER, or by accessing the Parker web site at www.parker.com.
- 4.3. Lockout / Tagout Procedures:** Be sure to follow all required lockout and tagout procedures when servicing equipment. For more information see: OSHA Standard – 29 CFR, Part 1910.147, Appendix A, The Control of Hazardous Energy – (Lockout / Tagout)
- 4.4. Visual Inspection:** Any of the following conditions requires immediate system shut down and replacement of worn or damaged components:
- Air leakage: Look and listen to see if there are any signs of visual damage to any of the components in the system. Leakage is an indication of worn or damaged components.
 - Damaged or degraded components: Look to see if there are any visible signs of wear or component degradation.
 - Kinked, crushed, or damaged hoses. Kinked hoses can result in restricted air flow and lead to unpredictable system behavior.
 - Any observed improper system or component function: Immediately shut down the system and correct malfunction.
 - Excessive dirt build-up: Dirt and clutter can mask potentially hazardous situations.

Caution: Leak detection solutions should be rinsed off after use.

- 4.5. Routine Maintenance Issues:**
- Remove excessive dirt, grime and clutter from work areas.
 - Make sure all required guards and shields are in place.
- 4.6. Functional Test:** Before initiating automatic operation, operate the system manually to make sure all required functions operate properly and safely.
- 4.7. Service or Replacement Intervals:** It is the user's responsibility to establish appropriate service intervals. Valves, FRLs and vacuum products contain components that age, harden, wear, and otherwise deteriorate over time. Environmental conditions can significantly accelerate this process. Valves, FRLs and vacuum components need to be serviced or replaced on routine intervals. Service intervals need to be established based on:
- Previous performance experiences.
 - Government and / or industrial standards.
 - When failures could result in unacceptable down time, equipment damage or personal injury risk.
- 4.8. Servicing or Replacing of any Worn or Damaged Parts:** To avoid unpredictable system behavior that can cause death, personal injury and property damage:
- Follow all government, state and local safety and servicing practices prior to service including but not limited to all OSHA Lockout Tagout procedures (OSHA Standard – 29 CFR, Part 1910.147, Appendix A, The Control of Hazardous Energy – Lockout / Tagout).
 - Disconnect electrical supply (when necessary) before installation, servicing, or conversion.
 - Disconnect air supply and depressurize all air lines connected to system and Pneumatic Division products before installation, service, or conversion.
 - Installation, servicing, and / or conversion of these products must be performed by knowledgeable personnel who understand how pneumatic products are to be applied.
 - After installation, servicing, or conversions air and electrical supplies (when necessary) should be connected and the product tested for proper function and leakage. If audible leakage is present, or if the product does not operate properly, do not put product or system into use.
 - Warnings and specifications on the product should not be covered or painted over. If masking is not possible, contact your local representative for replacement labels.
- 4.9. Putting Serviced System Back into Operation:** Follow the guidelines above and all relevant Installation and Maintenance Instructions supplied with the valve FRL or vacuum component to insure proper function of the system.

The items described in this document and other documents and descriptions provided by Parker Hannifin Corporation, its subsidiaries and its authorized distributors ("Seller") are hereby offered for sale at prices to be established by Seller. This offer and its acceptance by any customer ("Buyer") shall be governed by all of the following Terms and Conditions. Buyer's order for any item described in its document, when communicated to Seller verbally, or in writing, shall constitute acceptance of this offer. All goods or work described will be referred to as "Products".

1. Terms and Conditions. Seller's willingness to offer Products, or accept an order for Products, to or from Buyer is expressly conditioned on Buyer's assent to these Terms and Conditions and to the terms and conditions found on-line at www.parker.com/saleterms/. Seller objects to any contrary or additional term or condition of Buyer's order or any other document issued by Buyer.

2. Price Adjustments; Payments. Prices stated on the reverse side or preceding pages of this document are valid for 30 days. After 30 days, Seller may change prices to reflect any increase in its costs resulting from state, federal or local legislation, price increases from its suppliers, or any change in the rate, charge, or classification of any carrier. The prices stated on the reverse or preceding pages of this document do not include any sales, use, or other taxes unless so stated specifically. Unless otherwise specified by Seller, all prices are F.O.B. Seller's facility, and payment is due 30 days from the date of invoice. After 30 days, Buyer shall pay interest on any unpaid invoices at the rate of 1.5% per month or the maximum allowable rate under applicable law.

3. Delivery Dates; Title and Risk; Shipment. All delivery dates are approximate and Seller shall not be responsible for any damages resulting from any delay. Regardless of the manner of shipment, title to any products and risk of loss or damage shall pass to Buyer upon tender to the carrier at Seller's facility (i.e., when it's on the truck, it's yours). Unless otherwise stated, Seller may exercise its judgment in choosing the carrier and means of delivery. No deferment of shipment at Buyers' request beyond the respective dates indicated will be made except on terms that will indemnify, defend and hold Seller harmless against all loss and additional expense. Buyer shall be responsible for any additional shipping charges incurred by Seller due to Buyer's changes in shipping, product specifications or in accordance with Section 13, herein.

4. Warranty. Seller warrants that the Products sold hereunder shall be free from defects in material or workmanship for a period of twelve months from the date of delivery to Buyer or 2,000 hours of normal use, whichever occurs first. This warranty is made only to Buyer and does not extend to anyone to whom Products are sold after purchased from Seller. The prices charged for Seller's products are based upon the exclusive limited warranty stated above, and upon the following disclaimer: **DISCLAIMER OF WARRANTY: THIS WARRANTY COMPRISES THE SOLE AND ENTIRE WARRANTY PERTAINING TO PRODUCTS PROVIDED HEREUNDER. SELLER DISCLAIMS ALL OTHER WARRANTIES, EXPRESS AND IMPLIED, INCLUDING MERCHANTABILITY AND FITNESS FOR A PARTICULAR PURPOSE.**

5. Claims; Commencement of Actions. Buyer shall promptly inspect all Products upon delivery. No claims for shortages will be allowed unless reported to the Seller within 10 days of delivery. No other claims against Seller will be allowed unless asserted in writing within 60 days after delivery or, in the case of an alleged breach of warranty, within 30 days after the date within the warranty period on which the defect is or should have been discovered by Buyer. Any action based upon breach of this agreement or upon any other claim arising out of this sale (other than an action by Seller for any amount due to Seller from Buyer) must be commenced within thirteen months from the date of tender of delivery by Seller or, for a cause of action based upon an alleged breach of warranty, within thirteen months from the date within the warranty period on which the defect is or should have been discovered by Buyer.

6. LIMITATION OF LIABILITY. UPON NOTIFICATION, SELLER WILL, AT ITS OPTION, REPAIR OR REPLACE A DEFECTIVE PRODUCT, OR REFUND THE PURCHASE PRICE. **IN NO EVENT SHALL SELLER BE LIABLE TO BUYER FOR ANY SPECIAL, INDIRECT, INCIDENTAL OR CONSEQUENTIAL DAMAGES ARISING OUT OF, OR AS THE RESULT OF, THE SALE, DELIVERY, NON-DELIVERY, SERVICING, USE OR LOSS OF USE OF THE PRODUCTS OR ANY PART THEREOF, OR FOR ANY CHARGES OR EXPENSES OF ANY NATURE INCURRED WITHOUT SELLER'S WRITTEN CONSENT, EVEN IF SELLER HAS BEEN NEGLIGENT, WHETHER IN CONTRACT, TORT OR OTHER LEGAL THEORY. IN NO EVENT SHALL SELLER'S LIABILITY UNDER ANY CLAIM MADE BY BUYER EXCEED THE PURCHASE PRICE OF THE PRODUCTS.**

7. Contingencies. Seller shall not be liable for any default or delay in performance if caused by circumstances beyond the reasonable control of Seller.

8. User Responsibility. The user, through its own analysis and testing, is solely responsible for making the final selection of the system and Product and assuring that all performance, endurance, maintenance, safety and warning requirements of the application are met. The user must analyze all aspects of the application and follow applicable industry standards and Product information. If Seller provides Product or system options, the user is responsible for determining that such data and specifications are suitable and sufficient for all applications and reasonably foreseeable uses of the Products or systems.

9. Loss to Buyer's Property. Any designs, tools, patterns, materials, drawings, confidential information or equipment furnished by Buyer or any other items which become Buyer's property, may be considered obsolete and may be destroyed by Seller after two consecutive years have elapsed without Buyer placing an order for the items which are manufactured using such property. Seller shall not be responsible for any loss or damage to such property while it is in Seller's possession or control.

10. Special Tooling. A tooling charge may be imposed for any special tooling, including without limitation, dies, fixtures, molds and patterns, acquired to manufacture Products. Such special tooling shall be and remain Seller's property notwithstanding payment of any charges by Buyer. In no event will Buyer acquire any interest in apparatus belonging to Seller which is utilized in the manufacture of the Products, even if such apparatus has been specially converted or adapted for such manufacture and notwithstanding any charges paid by Buyer. Unless otherwise agreed, Seller shall have the right to alter, discard or otherwise dispose of any special tooling or other property in its sole discretion at any time.

11. Buyer's Obligation; Rights of Seller. To secure payment of all sums due or otherwise, Seller shall retain a security interest in the goods delivered and this agreement shall be deemed a Security Agreement under the Uniform Commercial Code. Buyer authorizes Seller as its attorney to execute and file on Buyer's behalf all documents Seller deems necessary to perfect its security interest. Seller shall have a security interest in, and lien upon, any property of Buyer in Seller's possession as security for the payment of any amounts owed to Seller by Buyer.

12. Improper use and Indemnity. Buyer shall indemnify, defend, and hold Seller harmless from any claim, liability, damages, lawsuits, and costs (including attorney fees), whether for personal injury, property damage, patent, trademark or copyright infringement or any other claim, brought by or incurred by Buyer, Buyer's employees, or any other person, arising out of: (a) improper selection, improper application or other misuse of Products purchased by Buyer from Seller; (b) any act or omission, negligent or otherwise, of Buyer; (c) Seller's use of patterns, plans, drawings, or specifications furnished by Buyer to manufacture Product; or (d) Buyer's failure to comply with these terms and conditions. Seller shall not indemnify Buyer under any circumstance except as otherwise provided.

13. Cancellations and Changes. Orders shall not be subject to cancellation or change by Buyer for any reason, except with Seller's written consent and upon terms that will indemnify, defend and hold Seller harmless against all direct, incidental and consequential loss or damage. Seller may change product features, specifications, designs and availability with notice to Buyer.

14. Limitation on Assignment. Buyer may not assign its rights or obligations under this agreement without the prior written consent of Seller.

15. Entire Agreement. This agreement contains the entire agreement between the Buyer and Seller and constitutes the final, complete and exclusive expression of the terms of the agreement. All prior or contemporaneous written or oral agreements or negotiations with respect to the subject matter are herein merged.

16. Waiver and Severability. Failure to enforce any provision of this agreement will not waive that provision nor will any such failure prejudice Seller's right to enforce that provision in the future. Invalidation of any provision of this agreement by legislation or other rule of law shall not invalidate any other provision herein. The remaining provisions of this agreement will remain in full force and effect.

17. Termination. This agreement may be terminated by Seller for any reason and at any time by giving Buyer thirty (30) days written notice of termination. In addition, Seller may by written notice immediately terminate this agreement for the following: (a) Buyer commits a breach of any provision of this agreement (b) the appointment of a trustee, receiver or custodian for all or any part of Buyer's property (b) the filing of a petition for relief in bankruptcy of the other Party on its own behalf, or by a third party (c) an assignment for the benefit of creditors, or (d) the dissolution or liquidation of the Buyer.

18. Governing Law. This agreement and the sale and delivery of all Products hereunder shall be deemed to have taken place in and shall be governed and construed in accordance with the laws of the State of Ohio, as applicable to contracts executed and wholly performed therein and without regard to conflicts of laws principles. Buyer irrevocably agrees and consents to the exclusive jurisdiction and venue of the courts of Cuyahoga County, Ohio with respect to any dispute, controversy or claim arising out of or relating to this agreement. Disputes between the parties shall not be settled by arbitration unless, after a dispute has arisen, both parties expressly agree in writing to arbitrate the dispute.

19. Indemnity for Infringement of Intellectual Property Rights. Seller shall have no liability for infringement of any patents, trademarks, copyrights, trade dress, trade secrets or similar rights except as provided in this Section. Seller will defend and indemnify Buyer against allegations of infringement of U.S. patents, U.S. trademarks, copyrights, trade dress and trade secrets ("Intellectual Property Rights"). Seller will defend at its expense and will pay the cost of any settlement or damages awarded in an action brought against Buyer based on an allegation that a Product sold pursuant to this Agreement infringes the Intellectual Property Rights of a third party. Seller's obligation to defend and indemnify Buyer is contingent on Buyer notifying Seller within ten (10) days after Buyer becomes aware of such allegations of infringement, and Seller having sole control over the defense of any allegations or actions including all negotiations for settlement or compromise. If a Product is subject to a claim that it infringes the Intellectual Property Rights of a third party, Seller may, at its sole expense and option, procure for Buyer the right to continue using the Product, replace or modify the Product so as to make it noninfringing, or offer to accept return of the Product and return the purchase price less a reasonable allowance for depreciation. Notwithstanding the foregoing, Seller shall have no liability for claims of infringement based on information provided by Buyer, or directed to Products delivered hereunder for which the designs are specified in whole or part by Buyer, or infringements resulting from the modification, combination or use in a system of any Product sold hereunder. The foregoing provisions of this Section shall constitute Seller's sole and exclusive liability and Buyer's sole and exclusive remedy for infringement of Intellectual Property Rights.

20. Taxes. Unless otherwise indicated, all prices and charges are exclusive of excise, sales, use, property, occupational or like taxes which may be imposed by any taxing authority upon the manufacture, sale or delivery of Products.

21. Equal Opportunity Clause. For the performance of government contracts and where dollar value of the Products exceed \$10,000, the equal employment opportunity clauses in Executive Order 11246, VEVRRA, and 41 C.F.R. §§ 60-1.4(a), 60-741.5(a), and 60-250.4, are hereby incorporated.

Parker Hannifin Corporation
Pneumatic Division
8676 E. M89
P.O. Box 901
Richland, MI 49083 USA
Tel: 269 629 5000
Fax: 269 629 5385

Applications Engineering
Phone: 877 321 4PDN Option #2
E-mail: pdnapps@parker.com
Customer Support
Phone: 877 321 4PDN Option #1
E-mail: pdncustsvc@parker.com
Web site: www.parker.com/pneumatics

