

Tru-Seal Pipe Thread Sealing Nuts

Catalog M8456-2

January, 2011

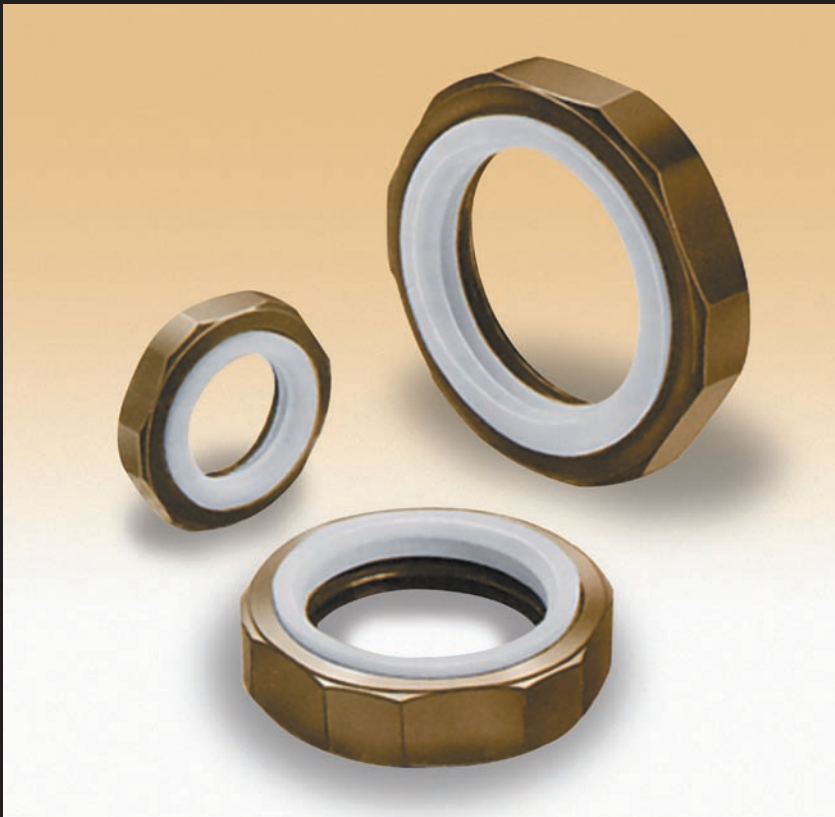

Durable, Leakproof Seal



The Effective Solution for Pipe Thread Leaks

Applications

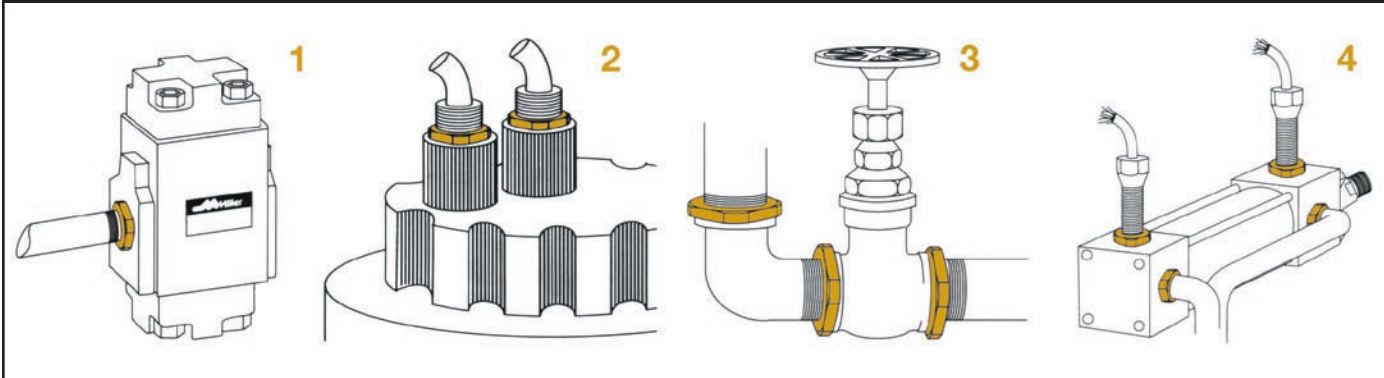

The Miller Tru-Seal is the original sealing locknut for threaded pipe connections. Tru-Seal can be found throughout the world preventing leaks and saving money. On pipe sizes up to 3", the Tru-Seal is available in pipe thread or straight thread in yellow zinc dichromate finished steel or stainless steel. Here are a few typical Tru-Seal Applications:

- 1. Hydraulic Valves**—Use Tru-Seals to prevent leaks in hydraulic systems. Shown here at a valve port, the Tru-Seal is effective up to 10,000 psi on 1/8" thru 1/2" pipe sizes, 5000 psi on 3/4" thru 1 1/4" pipe sizes, and 3000 psi on 1 1/2" and larger pipe sizes. The PTFE insert, impervious to virtually all fluids, recedes into the port to achieve the leakproof seal.
- 2. Fuel Pump**—The Tru-Seal can be used to seal flammable liquids. At any threaded connections, the Tru-Seals

will seal under severe corrosion, vibration and pressure conditions, as well as temperatures from -100°F to 500°F.

3. Piping Systems—Miller Tru-Seals save time in assembly and disassembly of piping. Position the component and use the Tru-Seal to tighten down the connection (illustrated in diagram below). PTFE tape and pipe dope can shred or crumble and contaminate a system—the Tru-Seal is especially useful in these operations. Tru-Seals are found in many gas, water, steam vacuum and chemical piping systems today, as well as fluid power.

4. Cylinder Ports—A natural fit in every cylinder operation, the Tru-Seal is great insurance against costly leaks when mounting valves, switches, or piping. The Tru-Seal's rounded corner design reduces the danger of over torquing these components.

Installation

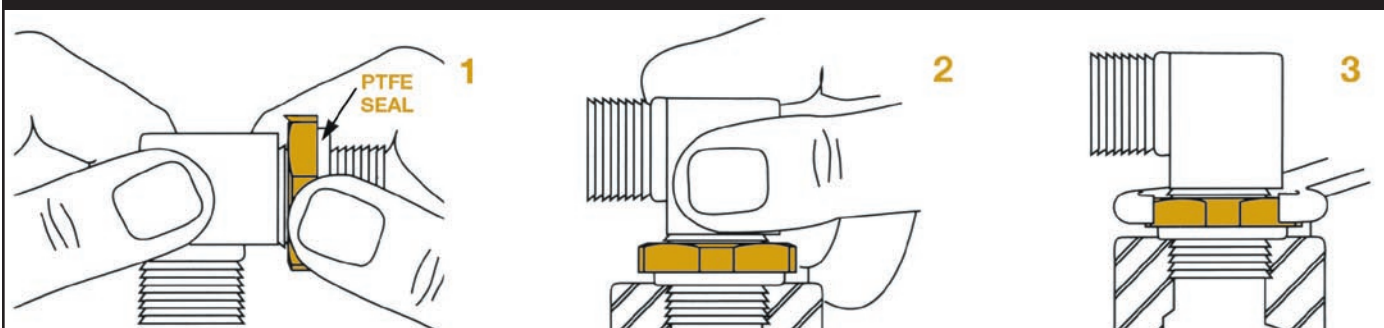

1. Thread Tru-Seal onto pipe or fitting until about four and one-half threads protrude beyond PTFE Seal.
2. Thread pipe or fitting a minimum of three full threads into port. Point in desired direction.
3. Using light to medium torque, tighten down Tru-Seal against port to complete leakproof assembly.

Part Numbers

SERIES 350—YELLOW ZINC DICHROMATE FINISH STEEL • PIPE THREAD SIZE N.P.T. (INCHES)

SIZE	1/8-27	1/4-18	3/8-18	1/2-14	3/4-14	1-11 1/2	1 1/4-11 1/2	1 1/2-11 1/2	2-11 1/2	2 1/2-8	3-8
PART #	TSE01-13	TSE01-25	TSE01-38	TSE01-50	TSE01-75	TSE01-100	TSE01-125	TSE01-150	TSE01-200	TSE01-250	TSE01-300

SERIES 350—303 STAINLESS STEEL • PIPE THREAD SIZE N.P.T. (INCHES)

SIZE	1/8-27	1/4-18	3/8-18	1/2-14	3/4-14	1-11 1/2	1 1/4-11 1/2	1 1/2-11 1/2	2-11 1/2		
PART #	TSE02-13	TSE02-25	TSE02-38	TSE02-50	TSE02-75	TSE02-100	TSE02-125	TSE02-150	TSE02-200		

SERIES 350—YELLOW ZINC DICHROMATE FINISH STEEL • STRAIGHT THREAD SIZE (INCHES)

SIZE	5/16-24	3/8-24	7/16-20	1/2-20	9/16-18	3/4-16	7/8-14	1 1/16-12	1 5/16-12	1 5/8-12	1 7/8-12	2 1/2-12
PART #	TSE11-31-24	TSE11-38-24	TSE11-44-20	TSE11-50-20	TSE11-56-18	TSE11-75-16	TSE11-88-14	TSE21-106-12	TSE21-131-12	TSE21-163-12	TSE21-188-12	TSE21-250-12

Dimensions

Pipe Thread N.P.T. (Inches)	Across Flats (Inches)	Across Corners (Inches)	Thickness (Inches)	Straight Thread (Inches)	Across Flats (Inches)	Across Corners (Inches)	Thickness (Inches)
1/8-27	5/8	.658	5/32	5/16-24	1/2	.527	11/64
1/4-18	3/4	.789	17/64	3/8-24	9/16	.592	11/64
3/8-18	7/8	.920	17/64	7/16-20	5/8	.658	3/16
1/2-14	1 1/8	1.184	17/64	1/2-20	11/16	.723	3/16
3/4-14	1 5/16	1.381	17/64	9/16-18	3/4	.789	15/64
1-11 1/2	1 5/8	1.710	23/64	3/4-16	15/16	.986	17/64
1 1/4-11 1/2	2	2.104	23/64	7/8-14	1 1/8	1.184	19/64
1 1/2-11 1/2	2 1/4	2.367	3/8	1 1/16-12	1 5/16	1.381	5/16
2-11 1/2	2 3/4	2.892	13/32	1 5/16-12	1 5/8	1.710	13/32
2 1/2-8	3 1/4	3.417	17/32	1 5/8-12	1 15/16	2.038	25/64
3-8	4	4.200	35/64	1 7/8-12	2 3/16	2.300	13/32
				2 1/2-12	2 7/8	3.023	29/64

Miller Fluid Power

500 South Wolf Road
Des Plaines, IL 60016 USA
Tel.: (847) 298-2400
Fax: (800) 892-1008
E-mail: MFPCylmktg@parker.com
Website: www.millerfluidpower.com

Miller Fluid Power

8485 Parkhill Drive
Milton, Ontario
Canada L9T 5E9
Tel.: (905) 693-3000
Fax: (905) 876-1958

All specifications and information subject
to change without notice or prior obligation.

M8456-2

