

Features

Network Connectivity

Offering

Valve series	P2M	P2H IO-Link	P2H Ethernet	PCH	Turck BL67
Moduflex	X				
H Series Micro	X				X
H Series ISO		X	X	X	X

Protocol	P2M	P2H IO-Link	P2H Ethernet	PCH	Turck BL67
IO-Link	X	X		X	
DeviceNet					X
EtherNet/IP™	X		X	X	X
PROFIBUS-DP					X
PROFINET	X		X	X	X
Modbus/TCP	X		X	X	X
EtherCAT	X		X	X	
PowerLink	X		X		
CANopen					X

Options	P2M	P2H IO-Link	P2H Ethernet	PCH	Turck BL67
24 Solenoid control	X*	X			X
32 Solenoid control			X	X	X
Digital inputs / outputs				X	X
Analog inputs / outputs					X
Class A IO-Link master module				X	X
Class B IO-Link Master module				X	
Short circuit protection on inputs				X	X
Current sensing outputs				X	X
DeviceNet subnet					X
Power over DeviceNet / CANopen					X
CANopen expansion					X

* Only 19 usable when used with Moduflex Valve

P2M Network Nodes (shown on H Micro & Moduflex)



Moduflex

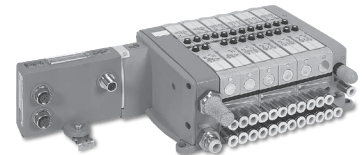

H Micro

P2H Network Node: IO-Link (shown on H Series ISO)

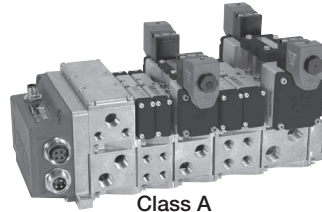

Class A

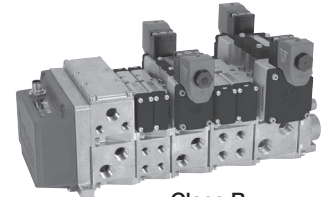

Class B

P2H Network Node: Industrial Ethernet (shown on H Series ISO)

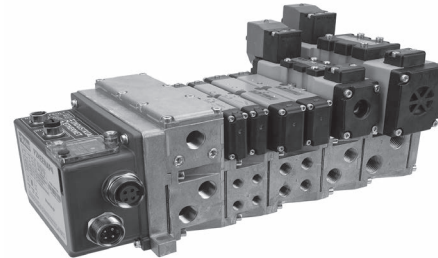

PCH Network Portal (shown on H Series ISO)

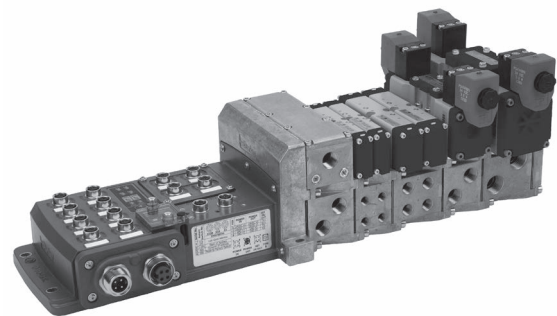

Turck Network Portal (shown on H Series ISO)

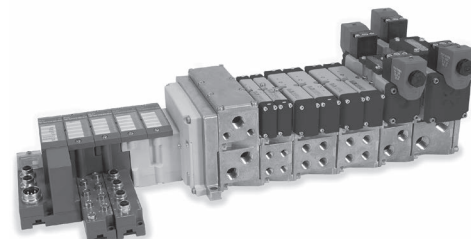

D

Subbase & Manual Valves

H Series Micro

Moduflex Series

H Series ISO

Network Connectivity

DX ISOMAX Series

Valvair II Series



For inventory, lead times, and kit lookup, visit www.pdnplu.com

Industrial Ethernet

Parker's extensive Network Connectivity portfolio can help lower cost of I/O in any control architecture.

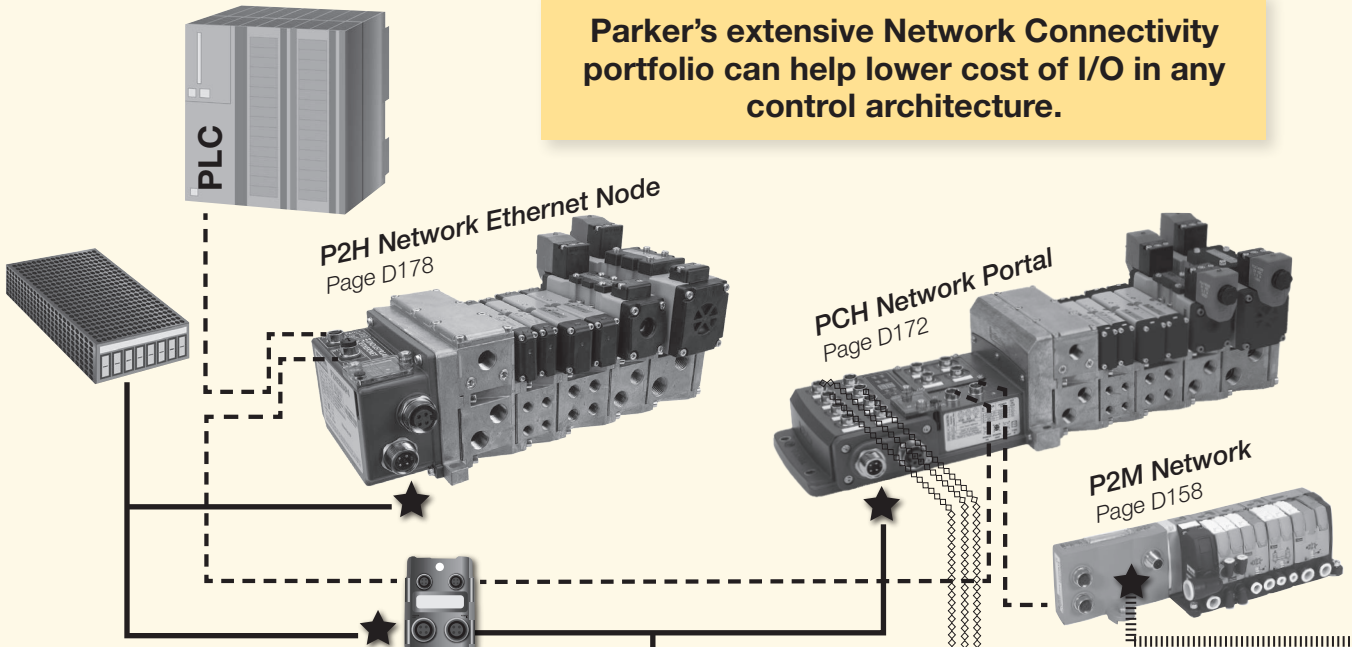

IO-Link

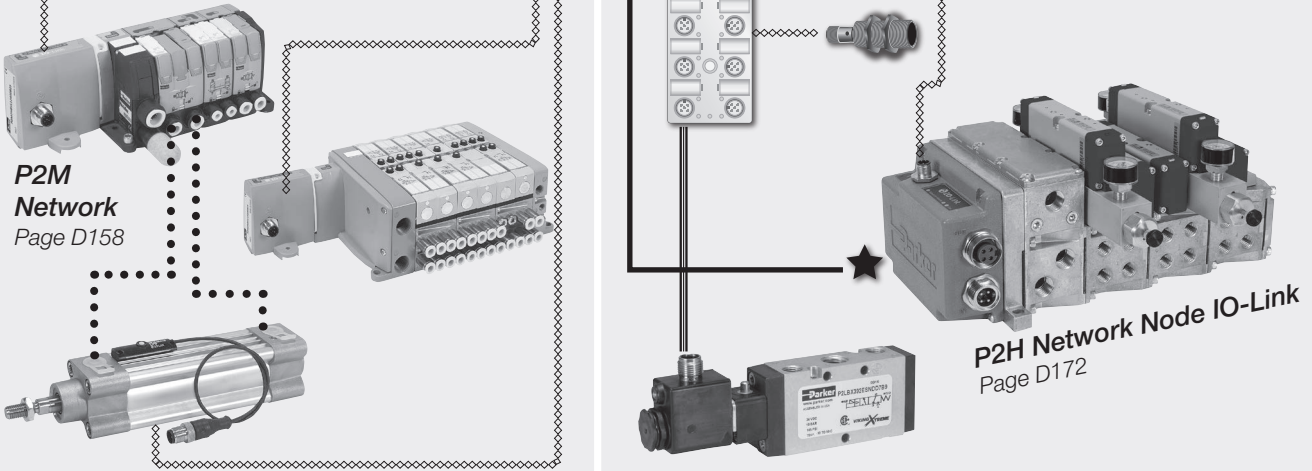

Network to Remote IO-Link Master
 Reduce cabinet size by using a de-centralized "on-machine" IO-Link Master

- * Control all local I/O with IO-Link Masters
 - Discrete I/O
 - "Smart" I/O
 - P2M IO-Link Class B & CPS pictured
[see www.parker.com/pdn/CPS](http://www.parker.com/pdn/CPS)
 and www.parker.com/pdn/P2M_IOL

Node Expansion Using IO-Link

- Reduce node count by adding an IO-Link Master module onto Turck Network manifold
- * 20m max length for I/O-Link cables
- * Control all "smart I/O" on 1 node
- * Reduce cost of secondary valve manifold
 - P2H IO-Link Class A pictured
 see www.parker.com/pdn/P2H_IOL

D

Subbase & Manual Valves

H Series Micro

Modulflex Series

H Series ISO

Network Connectivity

DX ISOMAX Series

Valvair-II Series



For inventory, lead times, and kit lookup, visit www.pdnplu.com

Features

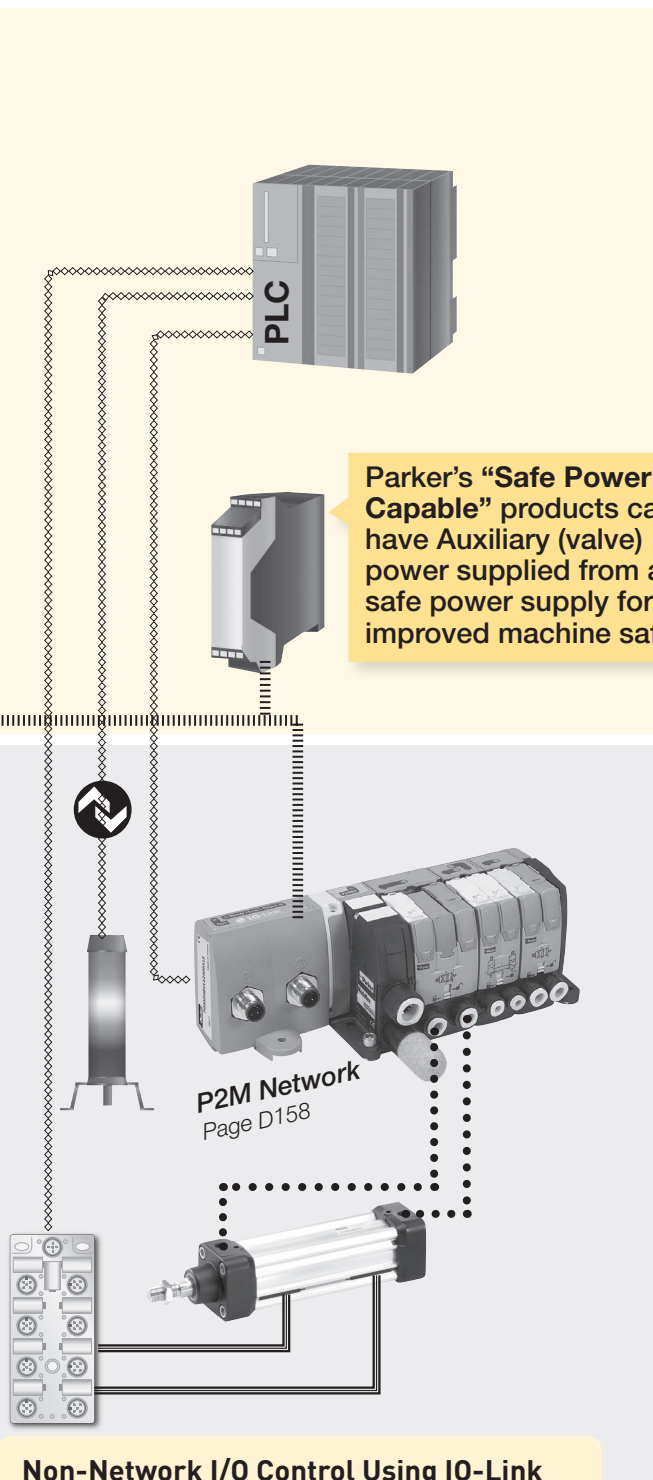

---	Industrial Network
.....	IO-Link
====	Discrete Wired Input / Output
—★	24 VDC Power
.....★	24 VDC SAFE Power
.....	Pneumatic

Parker's "Safe Power Capable" products can have Auxiliary (valve) power supplied from a safe power supply for improved machine safety.

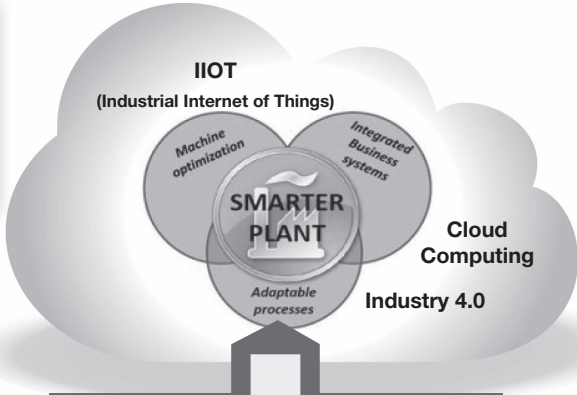

IO-Link is another step towards the smarter plant by lowering the cost for gathering component level prognostics and diagnostics.

Out of Tolerance Warnings

- * Voltage
- * Temperature

Error Descriptors

- * Solenoid short circuit
- * IO-Link communication error cycle count for each valve

Non-Network I/O Control Using IO-Link
Use PLC with integrated IO-Link Master for machines with smaller I/O counts

- * 20m max length for I/O-Link cables
- * Control all local I/O with IO-Link
 - Discrete I/O
 - "Smart" I/O
 - P2M IO-Link Class A pictured

- THIS IS EASIER** → Faster installation than discrete wiring
Standard IP67 M12 cable
- THIS IS SAVINGS** → Fewer network nodes
Easy expandability
- THIS IS VALUE** → Easy access diagnostics
Prognostics to prevent downtime



For inventory, lead times, and kit lookup, visit www.pdnplu.com

D153

Parker Hannifin Corporation
Pneumatic Division
Richland, Michigan
www.parker.com/pneumatics

D	Subbase & Manual Valves
H Series Micro	H Series ISO
Moduflex Series	Network Connectivity
DX ISOMAX Series	Valvair II Series

System Overview - Discrete Wiring

- Up to 24 solenoids per manifold (19 when used with Moduflex Valve)
- Discretely wired solenoids - optimized for PLCs with onboard inputs and outputs
- 25-Pin D-Sub, 19-Pin Brad Harrison or M23, or 12-Pin M23 connectors available

Centralized Application

Valves Inside Control Cabinet

- Valves located near machine control
- Applications with caustic wash down, hazardous areas, or extreme temperatures

Disadvantages

- Difficult to troubleshoot
- Difficult to maintain
- Expensive bulkhead fittings
- Long wiring time in cabinet

De-centralized Application

Valves Outside Control Cabinet

- Valves located near application - ready for machine mounting
- IP65 rating suitable for dusty and wet environments

Disadvantages

- Difficult to troubleshoot
- Difficult to maintain
- Long wiring time in cabinet
- Long wiring time in junction box

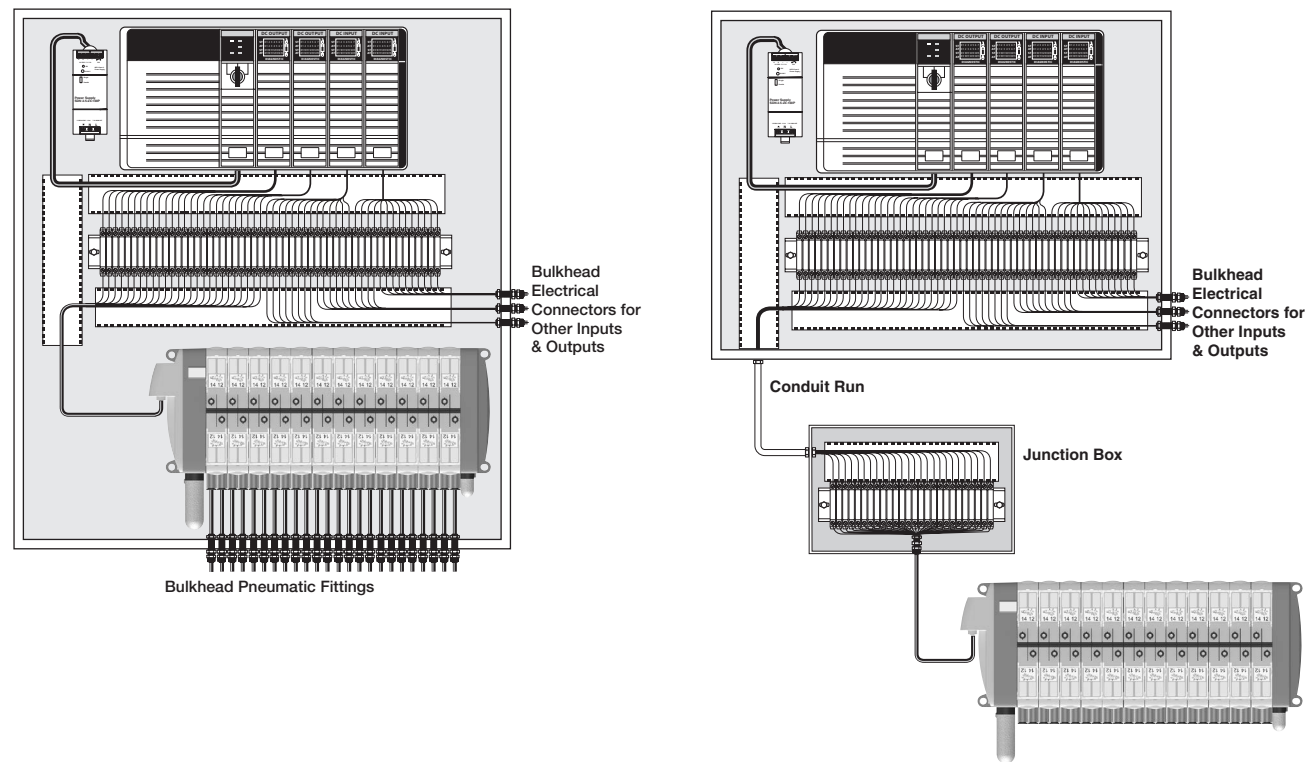

D	Subbase & Manual
Valves	H Series Micro
Moduflex Series	H Series ISO
Network Connectivity	DX ISOMAX Series
Valvair II Series	



For inventory, lead times, and kit lookup, visit www.pdnplu.com

Introduction to Control Systems

System Overview - P2M Network Node

- Up to 24 solenoids per manifold (19 when used with Moduflex Valve)
- Optimized for PLCs with network capability
- Routinely used on medium sized machines
- Connectivity to Moduflex, H Series Micro and H Series ISO valves

Centralized Application

Valves Inside Control Cabinet

- Valves located near machine control
- Applications with caustic wash down, hazardous areas, or extreme temperatures
- Additional inputs and outputs are not directly attached to valve manifold

Advantages

- Highest degree of environmental protection
- One location for all control devices
- Small size requires minimal cabinet space
- Eliminates terminal strips and wire ways for valves
- Greatly reduces wiring time
- Eliminates junction boxes for valves
- Eliminates conduit runs for valves

De-centralized Application

H Series Micro Outside Control Cabinet

- Valves located near application - ready for machine mounting
- IP65 rating suitable for dusty and wet environments
- Additional inputs and outputs are not directly attached to valve manifold

Advantages

- Smallest control cabinet
- Reduces tubing length and improves pneumatic response time
- Eliminates pneumatic bulk fittings on control cabinet
- Many network nodes can be attached to the network with little incremental cost – valve manifolds, inputs, outputs and other devices
- Eliminates terminal strips and wire ways for valves
- Greatly reduces wiring time
- Eliminates junction boxes for valves
- Eliminates conduit runs for valves

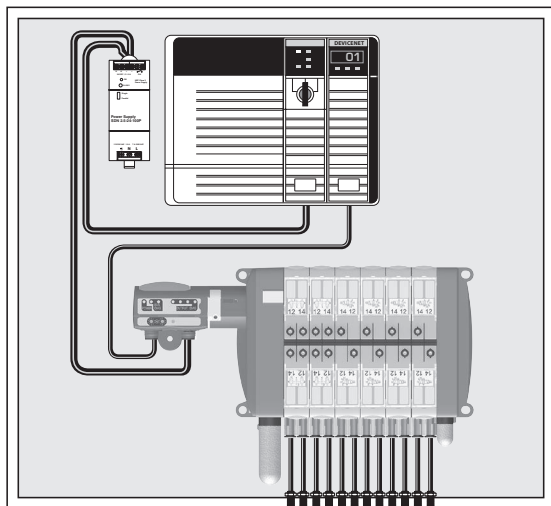

Bulkhead Pneumatic Fittings

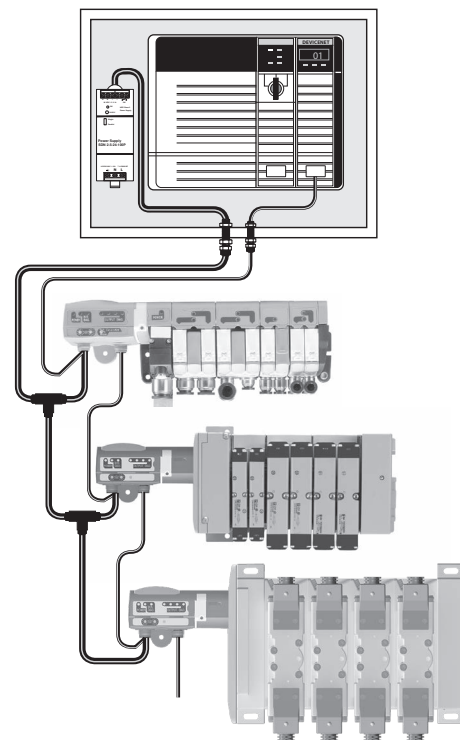

For inventory, lead times, and kit lookup, visit www.pdnplu.com

Introduction to Control Systems

System Overview - Turck Network Portal

General Product Features

- Turck Network Portal with up to 256 inputs / outputs and up to 16 or 32 solenoids per manifold
- Digital inputs / outputs, IO-Link Class A Master analog inputs / outputs, serial interface, counter modules, and RFID modules available
- Connectivity to H Series Micro and H Series ISO valve series

Advantages

- Handle all I/O from one node; eliminate PLC input / output cards
- Optimized for PLC's with network capability
- Eliminates junction boxes, terminal strips, and conduit runs for all inputs and outputs, greatly reducing wiring time

Centralized Application

Valves Inside Control Cabinet

- Valves located near machine control
- Applications with caustic wash down, hazardous areas, or extreme temperatures

Advantages

- Highest degree of environmental protection
- One location for all control devices
- Small size requires minimal cabinet space

De-centralized Application

Valves Outside Control Cabinet

- Valves located near application - ready for machine mounting
- IP65 rating suitable for dusty and wet environments

Advantages

- Smallest control cabinet
- Reduces tubing length and improves response time
- Eliminates pneumatic bulk fittings on control cabinet

D

Subbase & Manual
Valves

H Series
Micro

Modulflex
Series

H Series
ISO

Network
Connectivity

DX ISOMAX
Series

Valvair II
Series

EtherNet/IP™



Modbus/TCP™

DeviceNet™



CANopen

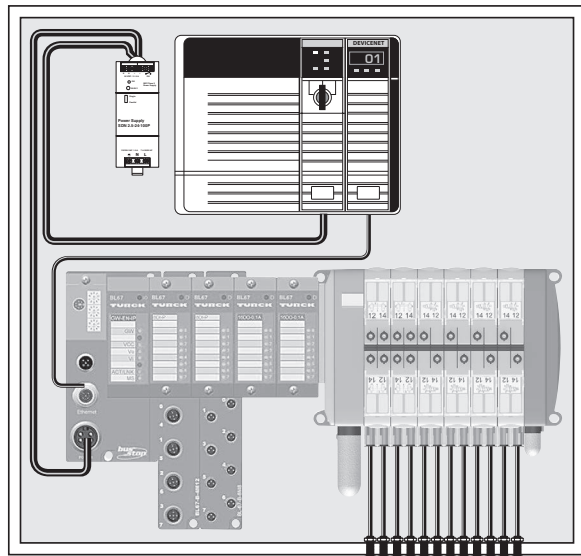

Bulkhead Pneumatic Fittings

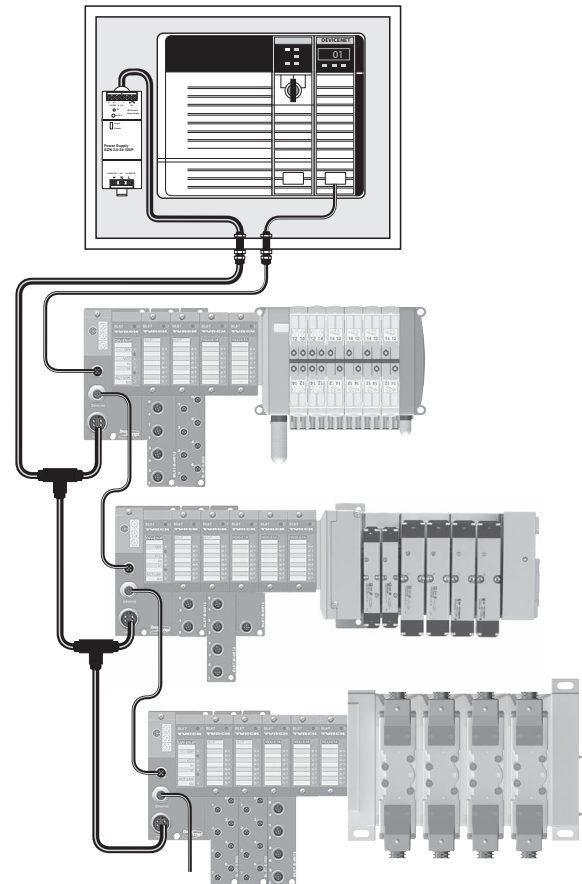

For inventory, lead times, and kit lookup, visit www.pdnplu.com

Introduction to Control Systems

System Overview - Turck Network Portal with CANopen Expansion

General Product Features

- Turck Network Portal with up to 256 inputs / outputs and up to 16 or 32 solenoids per manifold
- Digital inputs / outputs, IO-Link Class A Master analog inputs / outputs, serial interface, counter modules, and RFID modules available
- Connectivity to H Series Micro and H Series ISO valves

CANopen Expansion Features

- Using a CANopen interface module, a CANopen subnet is created within the Turck Network Portal, controlling an additional 64 inputs, outputs, or solenoids
- The CANopen subnet is independent of the main network, and is not visible to the master PLC
- Additional P2M CANopen modules can be attached to the CANopen subnet to provide a connection for 16 solenoids each
- Other 3rd party CANopen devices can also be used on this network, within the 64 bit CANopen expansion limit

System Advantages

- Handle all I/O from one node; eliminate PLC input / output cards
- Optimized for PLC's with network capability
- Several CANopen nodes can be attached to the network – valve manifolds, inputs, outputs or other devices
- CANopen expansion allows additional devices to be attached to the system without a CANopen scanner card
- Eliminates junction boxes, terminal strips, and conduit runs for all inputs and outputs, greatly reducing wiring time

Centralized Application

Valves Inside Control Cabinet

- Valves located near machine control
- Applications with caustic wash down, hazardous areas, or extreme temperatures

Advantages

- Highest degree of environmental protection
- One location for all control devices
- Small size requires minimal cabinet space

De-centralized Application

Valves Outside Control Cabinet

- Valves located near application - ready for machine mounting
- IP65 rating suitable for dusty and wet environments

Advantages

- Smallest control cabinet
- Reduces tubing length and improves response time
- Eliminates pneumatic bulk fittings on control cabinet

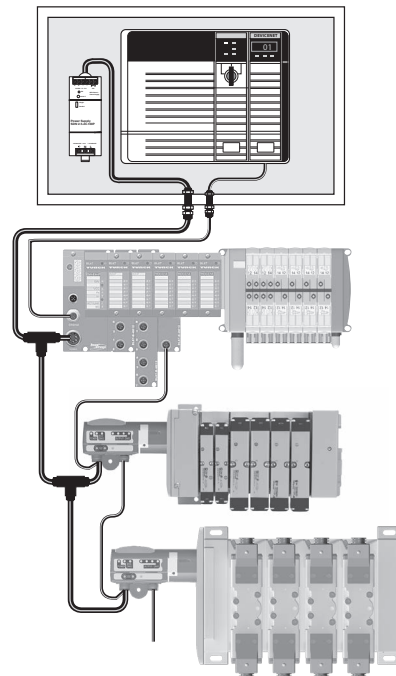
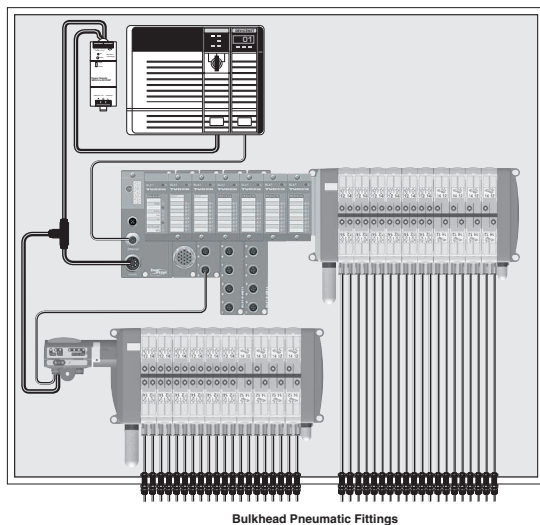
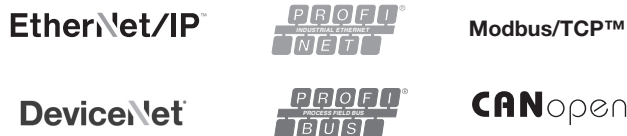

For inventory, lead times, and kit lookup, visit www.pdnplu.com

D157

Parker Hannifin Corporation
Pneumatic Division
Richland, Michigan
www.parker.com/pneumatics

D	Subbase & Manual Valves
H Series Micro	Modulflex Series
H Series ISO	Network Connectivity
DX ISOMAX Series	Valvair II Series

Introduction to Control Systems

System Overview - Turck Network Portal with BL Remote DeviceNet Subnet

General Product Features

- Turck Network Portal with up to 256 inputs / outputs and up to 16 or 32 solenoids per manifold
- Digital inputs / outputs, IO-Link Class A Master analog inputs / outputs, serial interface, counter modules, and RFID modules available
- Connectivity to H Series Micro and H Series ISO valves

BL Remote DeviceNet Subnet Features

- With BL remote DeviceNet subnet functionality, each communication module has its own DeviceNet master which provides a connection for 63 DeviceNet nodes with additional inputs, outputs, and solenoid control
- BL remote DeviceNet subnet is independent of the main network, and is not visible to the master PLC
- P2M DeviceNet modules can be attached to the subnet to provide a connection for 16 solenoids each
- Turck DeviceNet modules can be attached to the subnet to provide a connection for 16 or 32 solenoids each and inputs and outputs up to the 256 input and output limitation

System Advantages

- Handle all I/O from one node; eliminate PLC input / output cards
- Optimized for PLC's with network capability
- Many DeviceNet nodes can be attached to the network – valve manifolds, inputs, outputs or other devices
- Eliminates junction boxes, terminal strips, and conduit runs for all inputs and outputs, greatly reducing wiring time

Centralized Application

Valves Inside Control Cabinet

- Valves located near machine control
- Applications with caustic wash down, hazardous areas or extreme temperatures

Advantages

- Highest degree of environmental protection
- One location for all control devices
- Small size requires minimal cabinet space

De-centralized Application

Valves Outside Control Cabinet

- Valves located near application - ready for machine mounting
- IP65 rating suitable for dusty and wet environments

Advantages

- Smallest control cabinet
- Reduces tubing length and improves response time
- Eliminates pneumatic bulk fittings on control cabinet

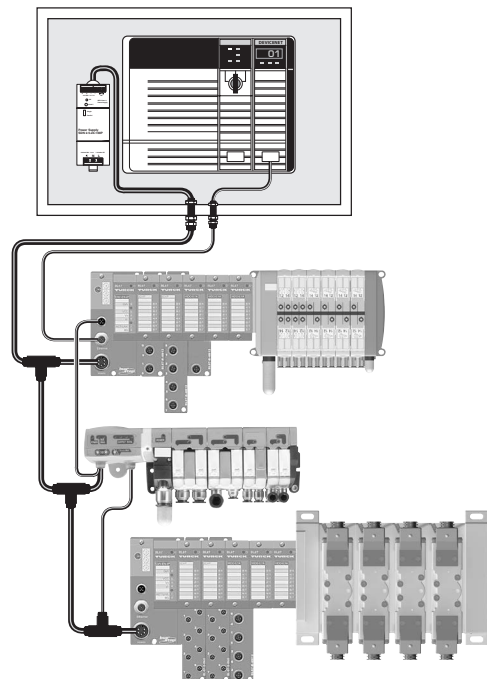
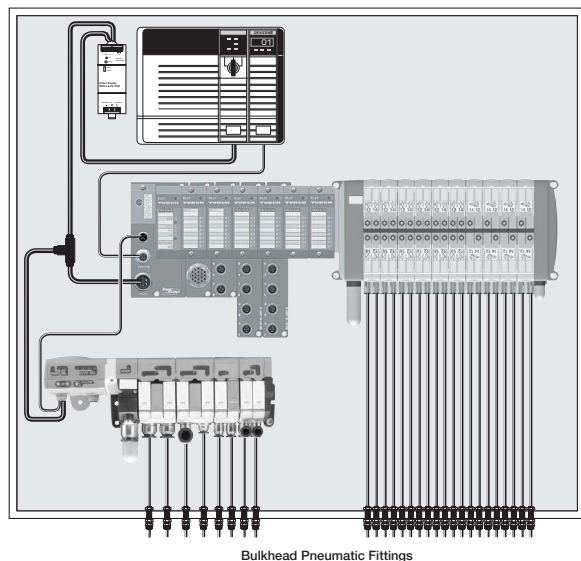

D
 Subbase & Manual Valves
 H Series Micro
 Modulflex Series
 H Series ISO
 Network Connectivity
 DX ISOMAX Series
 Valvair II Series



For inventory, lead times, and kit lookup, visit www.pdnplu.com

Introduction to Control Systems

System Overview - Turck Network Portal with Stand Alone Control using CoDeSys

General Product Features

- Turck Network Portal with up to 256 inputs / outputs and 32 solenoids per manifold
- Digital inputs / outputs, analog inputs / outputs, serial interface, counter modules, and RFID modules available
- Connectivity to H Series Micro and H Series ISO valves

Stand Alone Control Features

- Communication modules equipped with standalone control – programmed according to IEC61131-3 with CoDeSys
- 512KB program memory with 32 bit RISC processor
- Run 1000 instructions in less than 1 ms
- Optimized for PLC’s with network capability or standalone controllers that need to interface with other devices

System Advantages

- Handle all I/O and control with one system; eliminate the PLC when used as the main controller for smaller machines
- Reduces programming and bandwidth requirements on large machines with a master PLC controller by handling local I/O and interfacing with the PLC over the network
- Eliminates junction boxes, terminal strips, and conduit runs for all inputs and outputs, greatly reducing wiring time

Centralized Application Valves

Inside Control Cabinet

- Valves attached to the machine control
- Applications with caustic wash down, hazardous areas, or extreme temperatures

Advantages

- Highest degree of environmental protection
- One location for all control devices

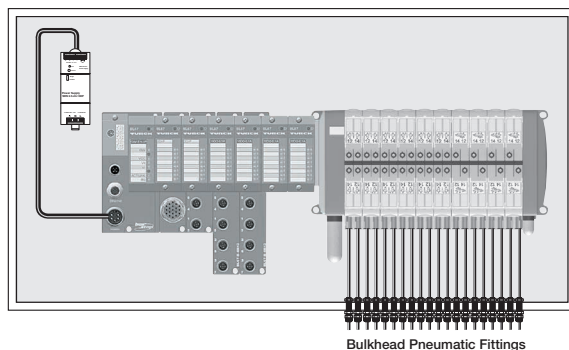

De-centralized Application

Valves Outside Control Cabinet

- Valves and machine control located near application - ready for machine mounting
- IP65 rating suitable for dusty and wet environments

Advantages

- No control cabinet needed when used as the main controller
- Reduces tubing length and improves response time
- Eliminates pneumatic bulk fittings on control cabinet

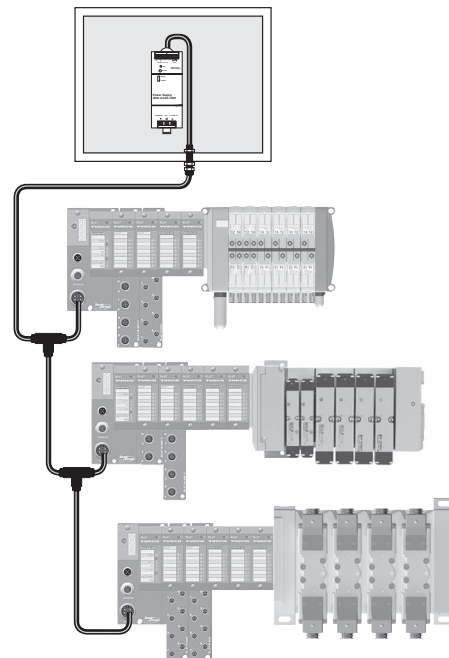

D

Subbase & Manual
Valves

H Series
Micro

Modulflex
Series

H Series
ISO

Network
Connectivity

DXISOMAX
Series

Valvair II
Series



For inventory, lead times, and kit
lookup, visit www.pdnplu.com

D160

Parker Hannifin Corporation
Pneumatic Division
Richland, Michigan
www.parker.com/pneumatics

Features

P2M Network Nodes

P2M communication modules directly attach to the Moduflex valve series as well as the P2M endplates of the H Series Micro. It offers a compact and low cost network solution.

Features

- Small, compact product design
- IO-Link Class A & Class B nodes
- Ethernet Communications
 - EtherNet/IP™
 - Profinet
 - EtherCat
 - Powerlink
 - ModbusTCP
- Channel-level diagnostics (LED and Electronic)
- Horizontal and vertical mounting without derating
- 5g vibration
- Quick-disconnects for I/O and network connectivity
- Built-in panel grounding
- CE certification



D

Subbase & Manual Valves

H Series Micro

Moduflex Series

H Series ISO

Network Connectivity

DX ISOMAX Series

Valvair II Series



For inventory, lead times, and kit lookup, visit www.pdnplu.com

D161

Parker Hannifin Corporation
Pneumatic Division
Richland, Michigan
www.parker.com/pneumatics

Features

P2M Network Nodes

P2M communication module attaches directly to the end plate. It offers a compact and low cost network solution.

Features

- Small, compact product design
- IO-Link Class A & Class B nodes
- Broad protocol offering
- Built-in panel grounding
- CE certification

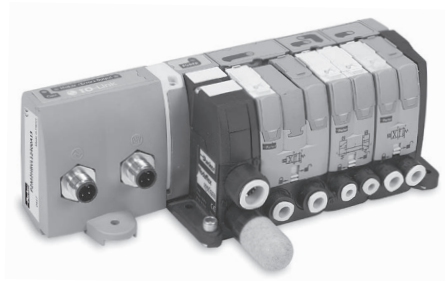

P2M2HBVL12400A13
(Class A IO-Link)

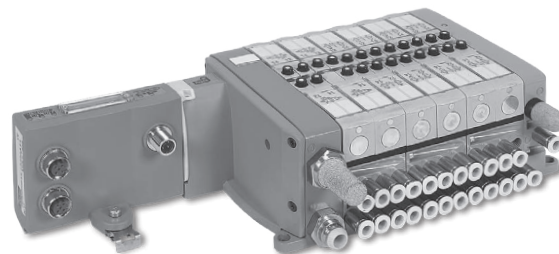

P2M2HBVE12400
(EtherNet/IP™)





D

Subbase & Manual Valves

	Industrial Ethernet Protocol	Maximum Addresses †	Part number
	EtherNet/IP™ (Safe Power Capable)	24 †	P2M2HBVE12400
	PROFINET (Safe Power Capable)	24 †	P2M2HBVN12400
	EtherCAT (Safe Power Capable)	24 †	P2M2HBVT12400
	Modbus/TCP (Safe Power Capable)	24 †	P2M2HBVM12400
	PowerLink (Safe Power Capable)	24 †	P2M2HBVW12400

H Series Micro

	IO-Link class	IO-Link	Aux. power	Aux. power pinout	Maximum addresses †	Part number	
						Standard	Safe power capable *
	Class A	3 Pins	3 Pins	1 & 3	24 †	P2M2HBVL12400A13	P2M2HBVL12400A13-SPC
		3 Pins	3 Pins	4 & 3	24 †	P2M2HBVL12400A43	P2M2HBVL12400A43-SPC
		3 Pins	5 Pins	4 & 2	24 †	P2M2HBVL12400A42	P2M2HBVL12400A42-SPC
	Class B	5 Pins		2 & 5	24 †	P2M2HBVL12400B25	P2M2HBVL12400B25-SPC

* Safe Power Capable (-SPC) version is suitable for connection to an OSSD (test pulsed) SAFE output source.

† If using with Modflex valves, maximum solenoid addresses limit is 19.

Further details: www.parker.com/pdn/P2M_IOL

 Most popular.

DX ISOMAX Series

Valvair II Series



For inventory, lead times, and kit lookup, visit www.pdnplu.com

P2M Industrial Ethernet Node

The P2M Industrial Ethernet 24 DO node allows a very simple and cost efficient connection to the most popular Industrial Ethernet networks.

Designed with isolated auxiliary power, it can easily be adapted to all power supply architectures and follow any required machine directives as Safe Power Capable.

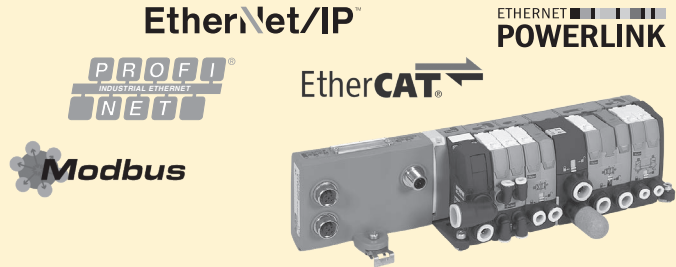

Simple Product Set-Up



The P2M Industrial Ethernet Node offers IP addressing through 3 rotary switches located on the top side.

The 3 rotary switches also allow for Factory Reset, IP address storage, and DHCP addressing.

If supported by the protocol used, the IP address can be modified through the embedded web page.

For an application requiring a regular disconnection / reconnection of communication & power, PROFINET and EtherNet/IP™ protocols allow respectively a Fast Start-Up (FSU) and Quick Connect mode. This mode can be enabled or disabled.

Topology / Integrated Ethernet Switch

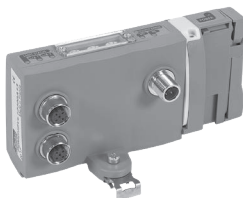

The P2M Industrial Ethernet 24 DO Node offers 2 Ethernet ports allowing a line topology without external switch. The Ring topology can also be supported (enable/disable) for PROFINET, EtherNet/IP™ and Modbus TCP/IP.

The integrated Ethernet switch supports Class C services allowing use in an isochronous real time (IRT) structure.

Easy Diagnostics – Local LEDs, Process (cyclic) data, Parameter (acyclic) data

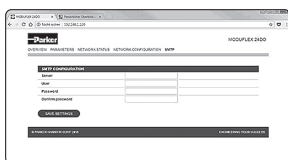

The P2M Industrial Ethernet 24 DO Node offers local diagnostics through 7 LED's located on the visible top side, showing:

- Logic status
- Ethernet activity on both ports
- Standard status due to protocol
- Output error / Auxiliary power

This local information as well as configuration and predictive maintenance diagnostics (Power monitoring, Solenoid cycle counting, etc) are available via both Process Data (cyclic) and Parameter Data (acyclic) via the PLC through the network and also easily viewable from the embedded web page.

When the PLC is NOT in control, the web page allows the user to force ON/OFF the solenoids state. This function has password protection.

Safe Power Capable

Auxiliary power of P2M Industrial Ethernet 24 DO Node can be supplied from a safe output device following machinery directives. This includes:

- Output Signal Switch Device (OSSD) test pulse compatible
- Galvanic isolation between 0 VDC Logic and Auxiliary power
- PP or PM cabling modes

For more details, refer to the user manuals located at www.parker.com/pdn/P2M_IE



For inventory, lead times, and kit lookup, visit www.pdnplu.com

D163

Parker Hannifin Corporation
 Pneumatic Division
 Richland, Michigan
www.parker.com/pneumatics

D

Subbase & Manual Valves

H Series Micro

Modulflex Series

H Series ISO

Network Connectivity

DX ISOMAX Series

Valvair II Series

P2M Industrial Ethernet Connections & Configuration

Ethernet ports and Auxiliary power connection

Ethernet ports: 2 x Standard Female M12 D-Coded – 5 pins
 Auxiliary Power: Standard Male M12 A-Coded – 4 pins

Configuration file

The configuration files (.EDS, .GDS, etc) can be download from the product web page.

Add on Instructions & Function Blocks

Add on Instructions & Function Blocks to assist in the configuration and programming of the P2M Node are available on the product web page – www.parker.com/pdn/P2M_IE

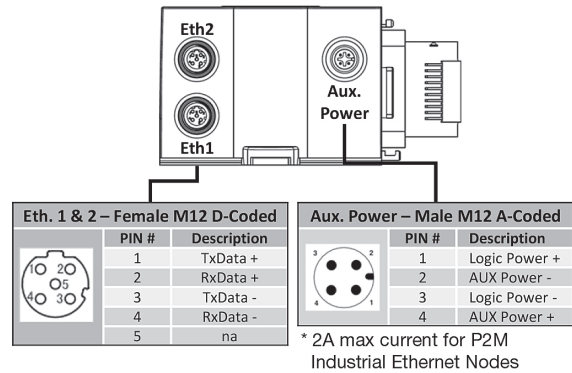

IP Address Setting

Can be done via Rotary Switches, DHCP, Web page, Ipconfig Tool or TCP/IP Interface Object, depending on protocol:

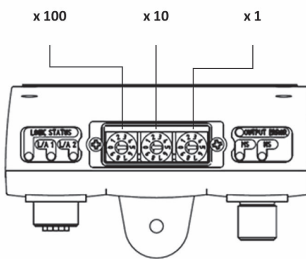

Description	EtherNet/IP™ Profinet IO Modbus TCP/IP	Ethernet PowerLink	EtherCAT
IP-Address setting stored into the NV-memory of the P2M node	000	000	N/A
IP-Address setting determined by the 3 rotary switches:			
• IP Address: 192.168.1.xxx	001 – 254	001 – 239	N/A
• Subnet Mask: 255.255.255.0			
• Default Gateway for 001: 192.168.1.2			
• Default Gateway for 002 - 254: 192.168.1.1			
The device will obtains its address via DHCP	888	N/A	N/A
Reset to factory status	999	999	999
Invalid, the module will not start	All others	All others	All others

P2M Industrial Ethernet Valve Control

All P2M Industrial Ethernet Modules can easily connect to and control pneumatic valves sizes ranging from 0.18 Cv to 6.0 Cv utilizing the Moduflex, H Micro, or H ISO valve series including the new H ISO Universal manifold which can mix ISO sizes 15407 (sizes 02 & 01) and 5599 (sizes 1 & 2) without transition plates.

P2M on Moduflex



P2M on H Series Micro

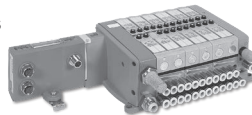

P2M Industrial Ethernet Node Output (Solenoid) data mapping - shown on Moduflex valve series

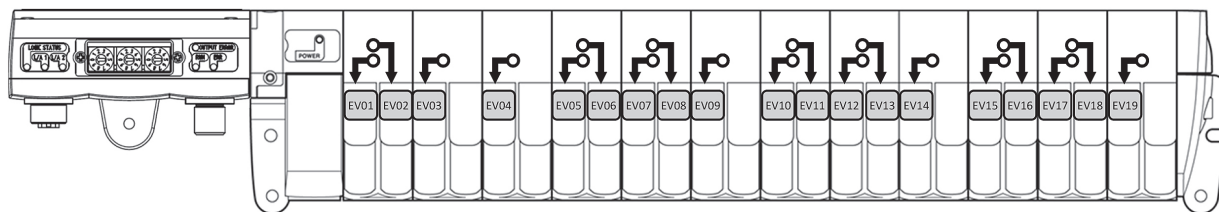

	7 3	2 0
Byte 0	EV08 EV01	
Byte 1	EV16 EV09	
Byte 2*	EV24 EV20	EV19 EV17

* Byte 2 / Bits 3 to 7 are only available when connected to H Series Micro or H Series ISO valve manifolds. The Moduflex valve series is limited to 19.

Process (Cyclic) Diagnostic through network via ADI #9 – “Module Error Input”

Easy to access diagnostic data transmitted to the PLC as Application Device Instance (ADI) #9

- Voltage warning, short circuit condition, module error, etc
- For more details refer to user manual on product web page – www.parker.com/pdn/P2M_IE

ADI	Instance name	Data type	Access
#9	Module error input	Unit 16	Read
Byte 0	Diag 7 Diag 0		
Byte 1	Reserved		



For inventory, lead times, and kit lookup, visit www.pdnplu.com

D
 Subbase & Manual Valves
 H Series Micro
 Moduflex Series
 H Series ISO
 Network Connectivity
 DX ISOMAX Series
 Valvair II Series

Valve Island V Series with Industrial Ethernet connection

EtherNet/IP™

EtherCAT®

The P2M Industrial Ethernet Lite node 24DO allows a very simple and cost efficient connection to the most popular Industrial Ethernet networks.

In its compact IP40 version equipped with two RJ45 Ethernet ports, it saves size in cabinet applications and offers an easy connection to the network in a line topology.

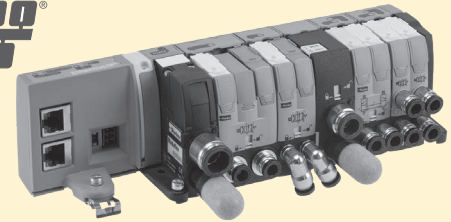

Industrial Ethernet Protocol	Part Number
Profinet IO	P2M2HBVE12400RJ
EtherNet/IP™	P2M2HBVN12400RJ
EtherCAT	P2M2HBVT12400RJ

Product Set-Up

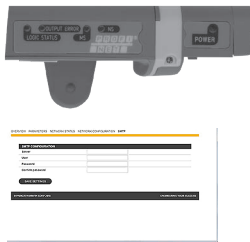

The P2M Lite Node 24DO is by default in DHCP mode. The module must be assigned to a static IP-Address in order to be controlled via the network.

The Network Configuration settings can be done through the embedded web server of the node as well as "IPconfig", "TIA Portal" or similar methods.

For an application requiring a regular disconnection / reconnection of the node, Profinet and EtherNet/IP™ protocols allow respectively a Fast Start-Up (FSU) and Quick Connect mode. This mode can be enable or disable .

Technology / Integrated Ethernet Switch



The P2M Industrial Ethernet Lite node 24DO offers 2 RJ45 ports allowing a line topology without external switch. The Ring topology can also be supported (enable/disable) for Profinet and EtherNet/IP™.

The integrated Ethernet switch support Class C Services allowing used in an isochronous real time (IRT) structure.

Diagnostic

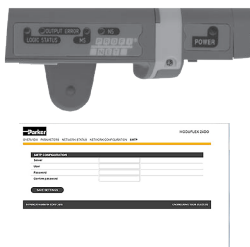

The P2M Industrial Ethernet Lite node 24DO offers a local diagnostic through 5 LED's located on the visible top side and 4 additional on both Ethernet connectors showing:

- Logic status
- Ethernet activity on both ports
- Standard Status due to protocol
- Output error / Power Supply

This local information as well as trouble shooting and predictive maintenance diagnostics (Power monitoring, Life cycle counting, ...) are available in PLC through the network and reported on imbedded web page.

When PLC is in "STOP", the web page allows to force ON/OFF solenoids state. This function has a password protection.

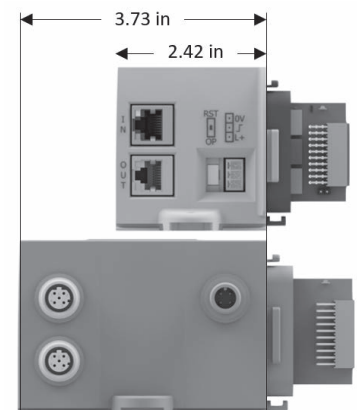

Save 1.31 inches with P2M Lite Node compared to P2M Ethernet Node



For inventory, lead times, and kit lookup, visit www.pdnplu.com

D165

Parker Hannifin Corporation
 Pneumatic Division
 Richland, Michigan
www.parker.com/pneumatics

D

Subbase & Manual Valves

H Series Micro

Modulflex Series

H Series ISO

Network Connectivity

DX ISOMAX Series

Valvair II Series

Industrial Ethernet Lite Node Connections and Diagnostic Functions

Ethernet and Power Connections

Network Communication Ports:

2 x Standard RJ45 Female connectors

Usage of standard manufactured cables available from your usual electrical supplier is recommended.

Power Supply:

Standard 3-Pin Male Connector - 3,81 mm pitch

Working mode selector:

DIP-switch

Configuration Files

The configuration files can be download from the product web page: www.parker.com/pde/P2M_IE

IP Address Setting

For both Profinet IO and EtherNet/IP™ protocols, the P2M Lite 24DO Node is by default in DHCP mode. The module must be assigned to a static IP-Address in order to be controlled via network. Please, refer to the user manual for IP-Address assignment process.

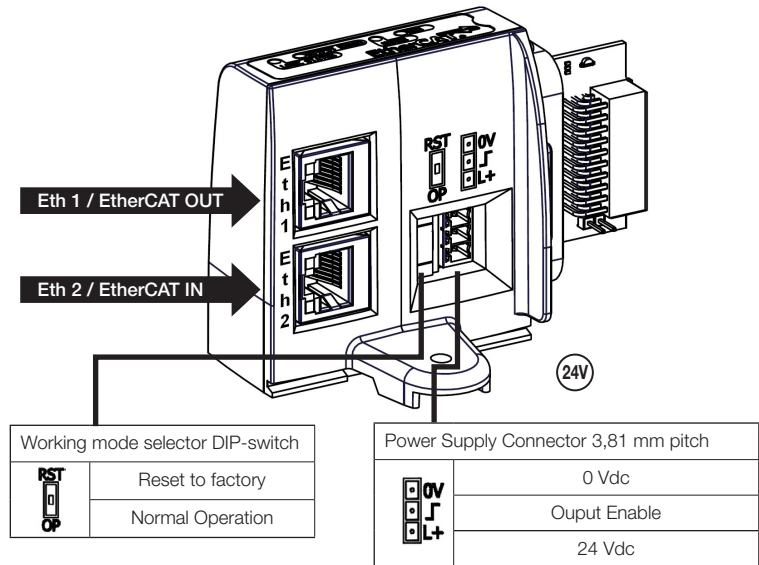

Local and Network Diagnostic Functions

Local Diagnostic

The P2M Lite 24DO node offers a local diagnostic via 9 LED's. Please refer to user manual with interpretation table.

Network Diagnostic

The P2M Lite 24DO Node offers additional useful module status information:

- Pilot overload or short circuit
- Power Voltage out of tolerance
- Cycle counter for every pilot
- Module temperature

For detailed technical information on the P2M Lite 24DO Node and a complete interpretation of node's diagnostic functionalities, please refer to the User Manual available from the product web page:

www.parker.com/pde/P2M_IE

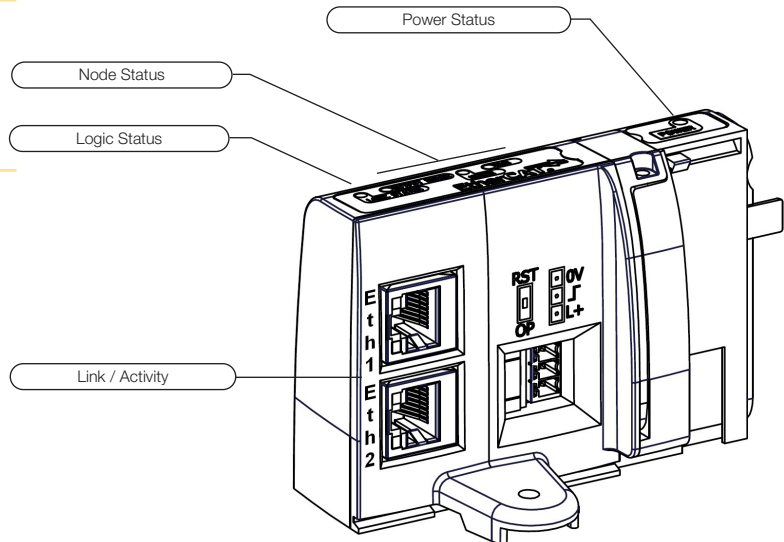

EtherNet/IP™



EtherCAT®

D
 Subbase & Manual Valves
 H Series Micro
 Modulflex Series
 H Series ISO
 Network Connectivity
 DX ISOMAX Series
 Valvair II Series



For inventory, lead times, and kit lookup, visit www.pdnplu.com

D166

Parker Hannifin Corporation
 Pneumatic Division
 Richland, Michigan
www.parker.com/pneumatics

Valve Island V Series with IO-Link connection

The P2M Moduflex IO-Link 24 DO node allows a very simple and cost efficient connection to any IO-Link master, centralised into the PLC or decentralised through an industrial Ethernet network.

Designed in both Class A and Class B versions with an isolated auxiliary power, it can easily be adapted to all power supply architectures and follow machine directives.

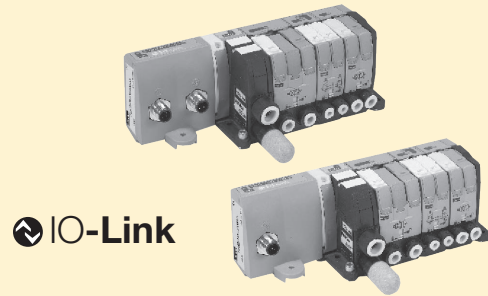

“V” Series Valve Island - P2M head module for IO-Link

Electrical Module for 24 outputs
 (The last 5 outputs of this 24 DO module can not be used with Moduflex Valve)



M12 A coded Connector connection

Description	IO-Link class	IO-Link	Aux. power	Aux. power pinout	Weight (g)	Part number	
						Standard	Safe power capable
Class A P2M IO-Link communication module	Class A	3 Pin's	3 Pin's	1 & 3	160	P2M2HBVL12400A13	P2M2HBVL12400A13-SPC
				4 & 3	160	P2M2HBVL12400A43	P2M2HBVL12400A43-SPC
				4 & 2	160	P2M2HBVL12400A42	P2M2HBVL12400A42-SPC
Class B	Class B	5 Pin's		2 & 5	140	P2M2HBVL12400B25	P2M2HBVL12400B25-SPC
Power & communication cable						RKC 4.5T*-RSC 4.5T/S1587	

IODD file can be downloaded from IODD Finder or the Moduflex web site:
<https://ioddfinder.io-link.com> or www.parker.com/pdn/io-link

Where * = 1, 2, 3, 4, 5, 10, 20 meter standard lengths

P2M Class A Module with Independent Auxiliary Power Supply

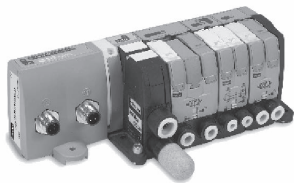

The P2M IO-Link Class A module can handle a Moduflex valve manifold having up to 19 solenoid outputs, or H Series Micro / ISO up to 24 solenoid outputs.

Thanks to its 2 x M12 A coded male connectors, the P2M node can be connected to any IO-Link Class A master and separately receive its auxiliary power supply for valves from an independent source.

The P2M IO-Link Class A module exists in 3 versions with the auxiliary power M12 connector pin out adapted to any sourcing through a standard M12 cable:

- P2M2HBVL12400A13 version: 24VDC / 0VDC on pins 1 & 3 – Standard version
- P2M2HBVL12400A43 version: 24VDC / 0VDC on pins 4 & 3 – Compatible with Siemens wiring
- P2M2HBVL12400A42 version: 24VDC / 0VDC on pins 4 & 2 – Compatible with Rockwell wiring and Turck wiring

P2M Class B Module

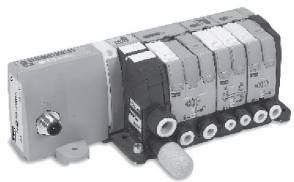

The P2M IO-Link Class B module can handle a Moduflex valve manifold having up to 19 solenoid outputs, or H Series Micro / ISO up to 24 solenoid outputs.

Thanks to its single M12 A coded male connectors, P2M node can be connected to any IO-Link Class B master receiving its auxiliary power supply for valves on pins 2 & 5 from the only cable simplifying the connection.

- P2M2HBVL12400B25 version: 24VDC / 0VDC on pins 2 & 5

Valve Series

Check the total maximum solenoid current consumption against the limit of the power supply and P2M module (standard version 4A, SPC version 2A).



Moduflex Valve
 Cv: .18 - 0.80
 19 Solenoids
 42mA per Sol.

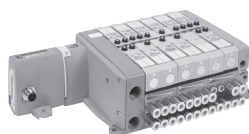

H Micro
 Cv: 0.35
 24 Solenoids
 42mA per Sol.



For inventory, lead times, and kit lookup, visit www.pdnplu.com

D167

Parker Hannifin Corporation
 Pneumatic Division
 Richland, Michigan
www.parker.com/pneumatics

D

Subbase & Manual Valves

H Series Micro

Moduflex Series

H Series ISO

Network Connectivity

DX ISOMAX Series

Valvair II Series

IO-Link Module Connection and Diagnostic Functions



IO-Link Module Connection

Standard male M12 – type A

Usage of standard manufactured cables available from your usual electrical supplier is recommended.

Note: Auxiliary power for solenoids can be wired allowing the user to turn outputs off while the communications remains on.

Configuration

IODD file can be downloaded from IODD Finder or the P2M web site:

<https://ioddfinder.io-link.com>
www.parker.com/pdn/P2M_IOL

Class B

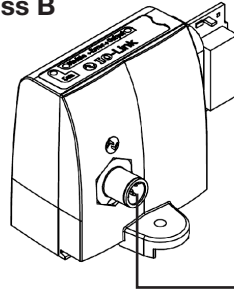

Class A

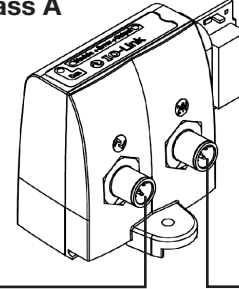

Legend

Symbol	Description
L+	IO-Link power supply "+"
L-	IO-Link power supply "-"
C/Q	IO-Link communication
Aux +	Auxiliary power supply 24 VDC
Aux -	Auxiliary power supply 0 VDC

M12 pin's	Class A		
	3 pin's		5 pin's
	P2M...A13	P2M...A43	P2M...A42
1	Aux +	Not used	Not used
2	-	-	Aux -
3	Aux -	Aux -	Not used
4	n.c.	Aux +	Aux +
5	-	-	Not used

Auxiliary Power Supply Compatibility

The P2M IO-Link Node can be powered from a 24VDC auxiliary source in PP or PM mode as grounds are isolated.

The P2M Safe Power Capable (-SPC) versions can be connected from a SAFE OSSD test pulsed power source.

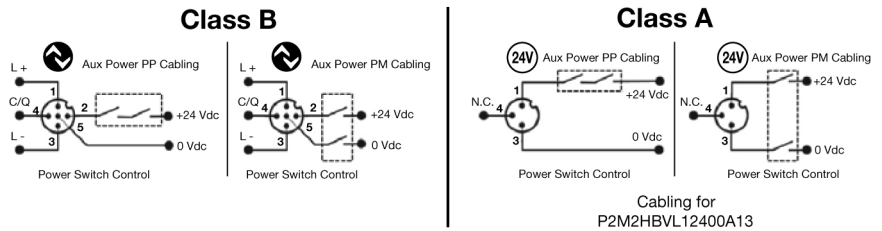

IO-Link Module Diagnostic Functions

The P2M IO-Link module offers additional useful module status information:

- Solenoid overload or short circuit
- Auxiliary voltage out of tolerance
- Cycle counter for each solenoid
- Module temperature

For more information on product technical information and module diagnostic functionalities, please refer to the user manual available from the product web page:

www.parker.com/pdn/P2M_IOL

COM Green LED			Module - Error Red LED			Error - Output Red LED			POWER Green LED		
LED Status	Description	Solving	LED Status	Description	Solving	LED Status	Description	Solving	LED Status	Description	Solving
OFF	IO-Link L+ / L- not powered	Check connection	OFF	Standard mode	NA	OFF	Standard mode	NA	OFF	AUX power failure	Check Auxiliary Power Supply
ON	IOL L+ / L- powered IO mode	Set IO-Link mode in IO-Link master	ON	24 VDC AUX power missing or any active malfunction	Check power supply or change module	ON	Any driver error (overload, over temperature, etc.)	Fix solenoid issue then acknowledge error	ON	Standard	NA
Blinking	IO-Link communication active	NA							Blinking	Aux Power is out of range, alarm level	Check Auxiliary Power Supply

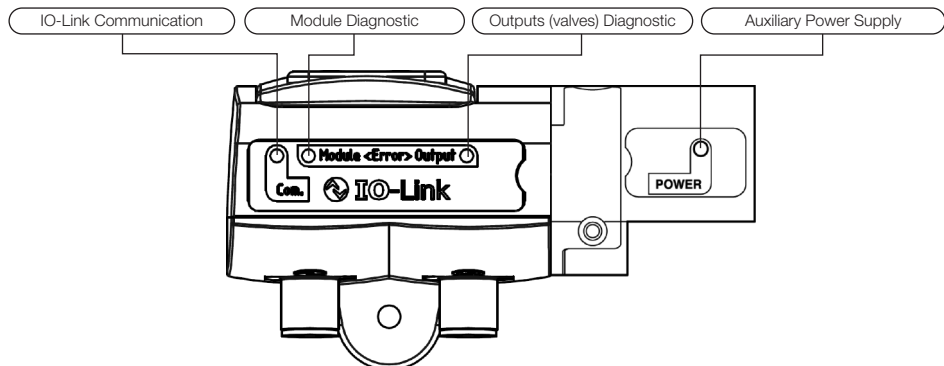

D
Subbase & Manual Valves
H Series Micro
Modulflex Series
H Series ISO
Network Connectivity
DX ISOMAX Series
Valvair II Series



For inventory, lead times, and kit lookup, visit www.pdnplu.com

D168

Parker Hannifin Corporation
 Pneumatic Division
 Richland, Michigan
www.parker.com/pneumatics

Input Data

One byte of diagnostic input data is transferred from P2M IO-Link to the IO-Link Master.

Process input data

7	6	5	4	3	2	1	0
Output driver SPI error	Output driver channel error	Polyfuse tripped	Temperature warning	SPI error	AUX voltage error	AUX voltage warning	Acknowledge Required

Output Data

Three bytes of process data are received by P2M IO-Link from the IO-Link Master for control of solenoids.

Process output data (Byte 0)

7	6	5	4	3	2	1	0
EV8	EV7	EV6	EV5	EV4	EV3	EV2	EV1

Process output data (Byte 1)

7	6	5	4	3	2	1	0
EV16	EV15	EV14	EV13	EV12	EV11	EV10	EV9

Process output data (Byte 2)

7	6	5	4	3	2	1	0
EV24	EV23	EV22	EV21	EV20	EV19	EV18	EV17

Solenoid Pilots Addressing and Process Mapping

P2M IO-Link node addressing used with Moduflex Valve System

The P2M IO-Link node, when used with Moduflex Valve System can handle up to 19 pilot solenoid valves. Addressing will be done as shown below.

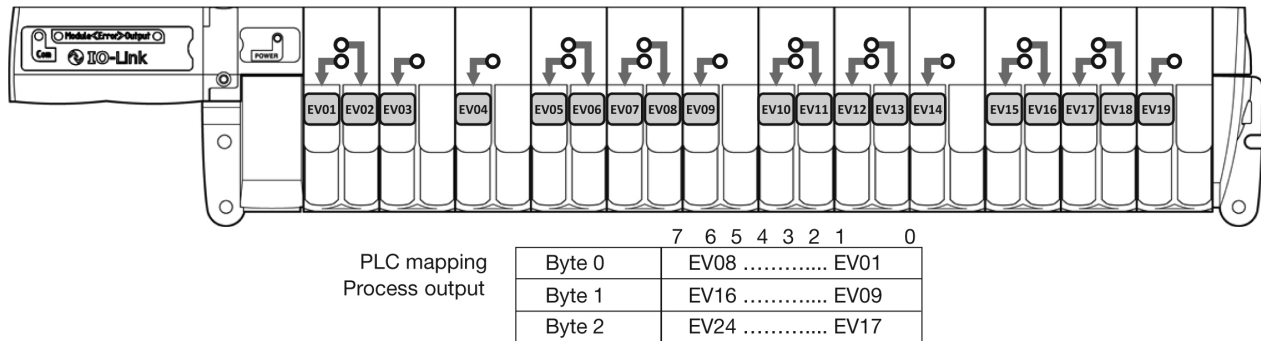

P2M IO-Link Module Electrical Specifications

IO-Link power supply	According to IO-Link standard V1.1.2
Speed communication	Com 2 – 38 kBd
Auxiliary power supply	20.4 VDC to 26.4 VDC
Current limit per channel	150 mA
Max current limit	4 A
Polarity inversion	YES
Short circuit protection	YES
Operating temperature	0°C to 55°C
Storage temperature	-25°C to 70°C
Shock according to IEC	60068-2-27:2008
Vibration according to IEC	60068-2-6:2007
EMC according to IEC	61000-4-2 up to -4-6

Network Diagnostic Through Process Mapping:

The P2M IO-Link module offers diagnostic data transmitted to the PLC through the master:

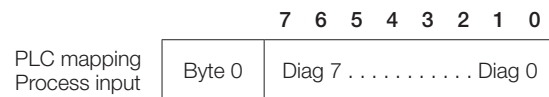

Diag bit	Error message	Detail
Diag 0.....	Fail-safe status	Acknowledgement required
Diag 1.....	Auxiliary voltage warning.....	Check auxiliary power
Diag 2.....	Auxiliary voltage failure.....	Check auxiliary power
Diag 3.....	Module failure	Module HS. must be replaced
Diag 4.....	Module over-temperature	
Diag 5.....	Module over-load	
Diag 6.....	Pilot solenoid(s) short circuit.....	Solenoid must be replaced
Diag 7.....	Outputs stage failure	

For further details, refer to the user manual: can be downloaded from www.parker.com/pdn/P2M_IOL



For inventory, lead times, and kit lookup, visit www.pdnplu.com

Solenoid Pilot Diagnostic Common to All P2M Nodes

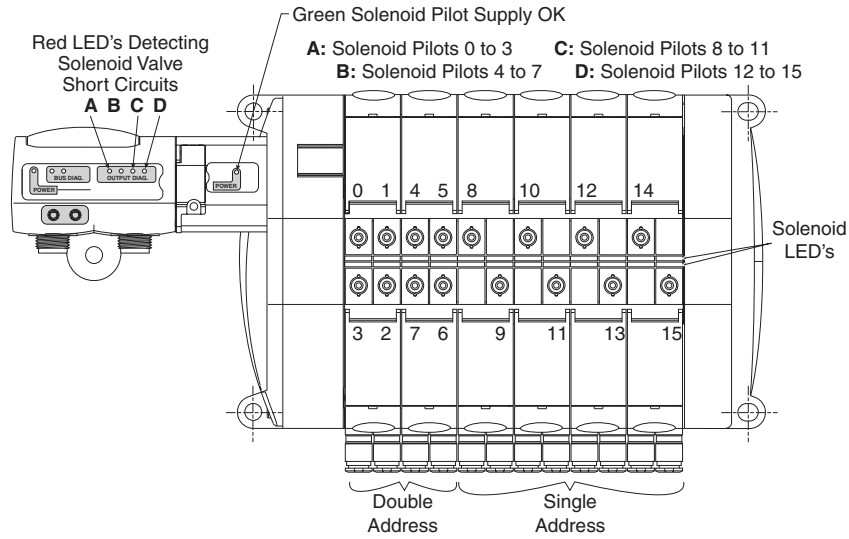

Inside the communication module, solenoid valve control is protected against short-circuits with the following visual indication provided:

- The red LEDs with code, shown above, detect solenoid valve short-circuits
- Supply is OK when the solenoid pilot power supply indicator is green

D
Subbase & Manual Valves
H Series Micro
Modulflex Series
H Series ISO
Network Connectivity
DX ISOMAX Series
Valvair II Series



For inventory, lead times, and kit lookup, visit www.pdnplu.com

Features

P2H IO-Link Node 24 DO

The P2H Network Node is available with IO-Link connectivity for the industries first connection of ISO valves (5599 & 15407) to the low cost IO-Link network.

Features

- Compact, robust product design
- Weld splatter resistant housing material
- Simple connection to IO-Link Class A or Class B masters
- Industries first power in & out capability for Class A version
- Industries first 7/8" power connectors on Class A version
- IO-Link connection to new H Series ISO Universal Manifold, capable of mixing valve sizes from 0.5 Cv – 3 Cv
- Safe Power Capable for supplying valve power from a safety device (ie. safe relay)
- Diagnostics made SIMPLE! Useful diagnostic flags in process (cyclic) data for easy access and use for preventative maintenance
- Certified to IP65 ingress protection
- CE certification

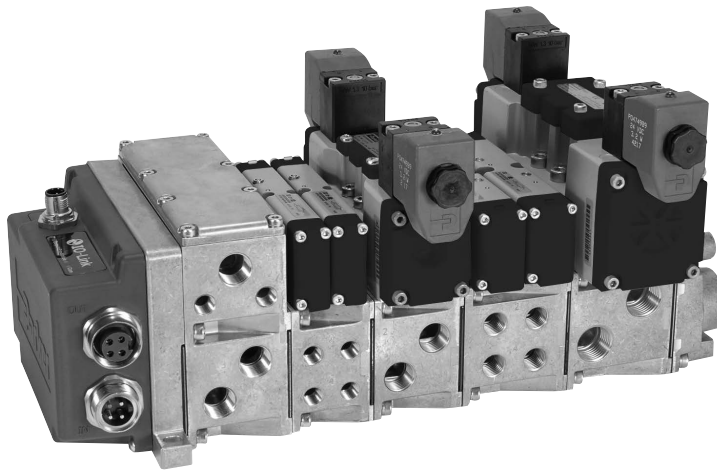

Class A Node

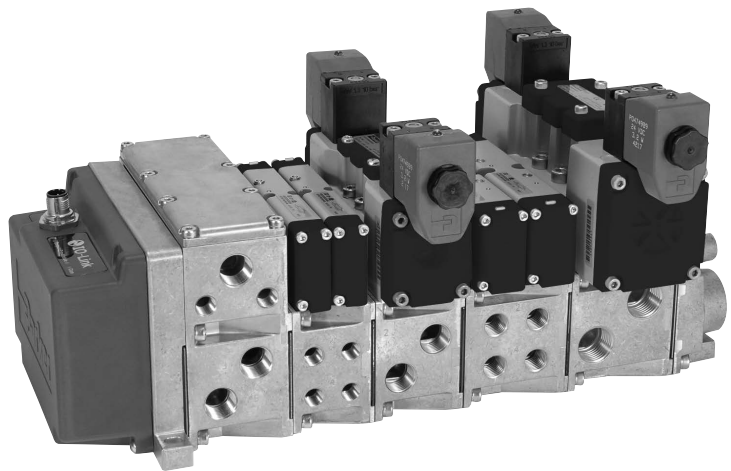

Class B Node

D

Subbase & Manual Valves

H Series Micro

Moduflex Series

H Series ISO

Network Connectivity

DX ISOMAX Series

Valvair II Series



For inventory, lead times, and kit lookup, visit www.pdnplu.com

D171

Parker Hannifin Corporation
Pneumatic Division
Richland, Michigan
www.parker.com/pneumatics

Features

Overview - P2H IO-Link Node 24 DO

Designed to integrate directly with all H Series ISO valve sizes, the P2H IO-Link Network Node provides a compact, robust and cost efficient solution for IO-Link capability. The P2H IO-Link network node is offered as an end plate kit on the H Series valve for five sizes (HB, HA, H1, H2 and H3). The P2H node is suitable for use on a valve manifold with up to 24 solenoid outputs.

Connection Types and Power:

Class A Node

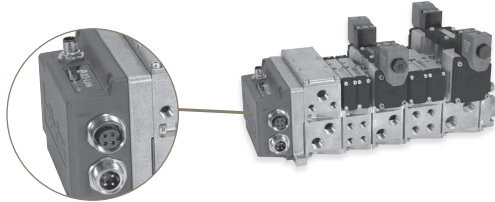

The Class A node has (1) 3 pin M12 connector for communication and logic power from any class A IO-Link master, and (2) 7/8" connectors for auxiliary valve power IN and OUT.

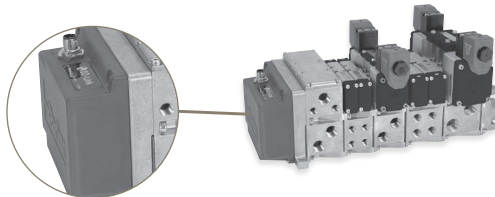

Class B Node



The Class B node has (1) 5 pin M12 connector to connect IO-Link for communication to a Class B IO-Link master, logic power and auxiliary power for the valve solenoids (up to the limit of the Class B node output*).

*It is recommended to use the Class A node with auxiliary power if the Class B master cannot provide enough power.

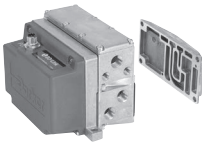
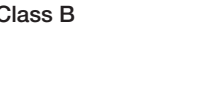
Left and Right Hand End Plate

	IO-Link class / type	Current	HB, HA, H1, H2 Valves		H3 Valves	
			NPT port	BSPP port	NPT port	BSPP port
 Class B	P2H IO-Link Class B, standard version, 24 address	3.2A max	PSHU20N200P	PSHU20N201P	PS4220N20DP	PS4220N21DP
 Class B	P2H IO-Link Class B, Safe Power Capable, 24 address	2.0A max	PSHU20S200P	PSHU20S201P	PS4220S20DP	PS4220S21DP
 Class A	P2H IO-Link Class A, 4-pin Safe Power Capable, 24 address	3.2A max	PSHU20S400P	PSHU20S401P	PS4220S40DP	PS4220S41DP
 Class A	P2H IO-Link Class A, 5-pin Safe Power Capable, 24 address	3.2A max	PSHU20S500P	PSHU20S501P	PS4220S50DP	PS4220S51DP

www.parker.com/pdn/P2H_IOL

Description	Standard version	- Safe power capable versions
IO-Link power supply	According to IO-Link standard V1.1.2	
Speed communication	Com 2 – 38 kBd	
Auxiliary power supply	voltage	20,4 VDC to 26,4 VDC
	OSSD compatibility	No Yes
Short circuit protection	Yes	
Operating temperature	0°C to +55°C	
Shock	According to IEC 60068-2-27:2008	
Vibration	According to IEC 60068-2-6:2007	
EMC	According to EN 55011 & EN 61000-4-2 to -4-6	
Ingress protection	Certified to IP65	

D
 Subbase & Manual Valves
 H Series Micro Series
 Modulflex Series
 H Series ISO
 Network Connectivity
 DX ISOMAX Series
 Valvair II Series



For inventory, lead times, and kit lookup, visit www.pdnplu.com

P2H IO-Link Node 24 DO – Connections and LED Diagnostics

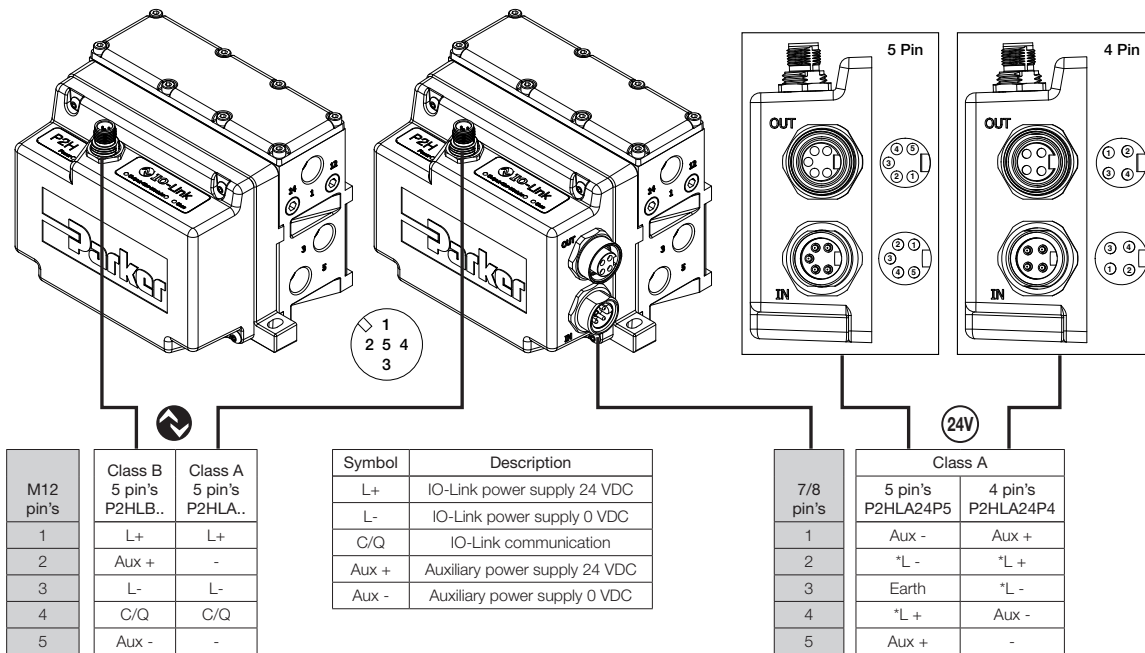

Note:

*7/8" logic power has no connection to internal P2H unit but does carryover to OUT 7/8" connector (for jumper logic power only). Logic power for P2H unit will be supplied from M12 (pin 1 & 3)

Local diagnostic through LED:

The P2H IO-Link Node offers a local diagnostic through 4 LED's status with interpretation described in the table below:

Power Green LED			Output<Err> Red LED			<Err>Module Red LED			Com Green LED		
LED Status	Description	Solving	LED Status	Description	Solving	LED Status	Description	Solving	LED Status	Description	Solving
OFF	Auxiliary power failure < 18V or > 28.5V	Check auxiliary power supply	OFF	Standard mode (No error active)	N/A	OFF	Standard mode (No error active)	N/A	OFF	IO-Link L+ / L- line not powered	Check IO-Link power supply from IO-Link Master (pin's 1 & 3)
ON	Standard mode (auxiliary power within normal range 20.4V* to 26.4V*)	N/A	ON	Any outputs driver error (auxiliary power error, overload, short circuit, over temperature, ...)	If auxiliary power OK (see Power LED status), check error messages and related troubleshooting	ON	24 VDC auxiliary power missing or any active malfunction	Check Auxiliary power supply. If auxiliary power supply OK, module must be replaced	ON	IO-Link L+ / L- line powered IO-Link master port set as SIO mode	Set IO-Link master channel in IO-Link mode
Blinking	Auxiliary power out of range (warning level*)	Check auxiliary power supply, check/reset adjusted values							Blinking	IO-Link communication active	N/A

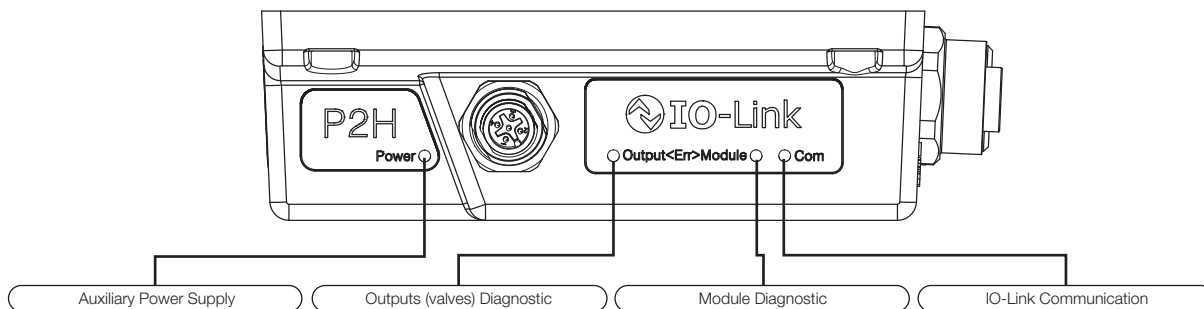

P2H IO-Link Node 24 DO – Connections and LED Diagnostics

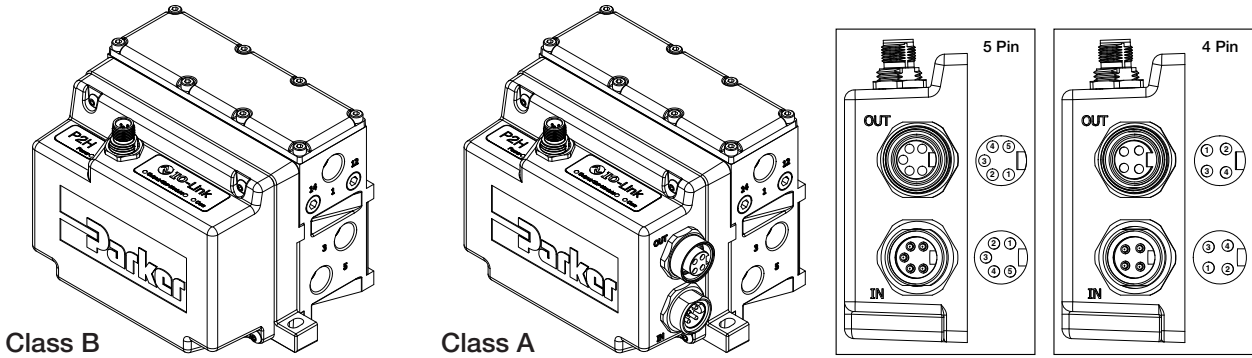

Class B

Class A



P2H IO-Link 24DO Node connection to SAFE Power PP / PM mode for valve control

The P2H IO-Link 24DO node can be powered from a SAFE 24 VDC auxiliary source in PP or PM mode as grounds are isolated. Auxiliary power for solenoids can be wired allowing the functionality to turn outputs OFF while communications remain active.

Class A – 5 Pin

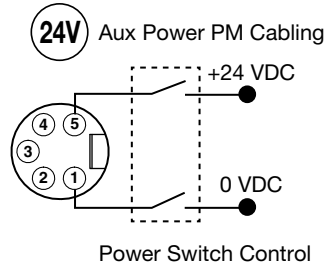
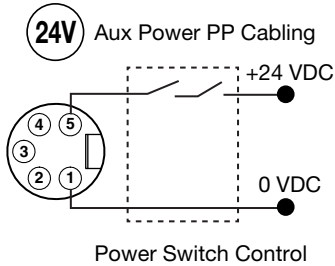

Pin Number	Address
1	AUX-
2	*L-
3	Earth
4	*L+
5	AUX+

Class A – 4 Pin

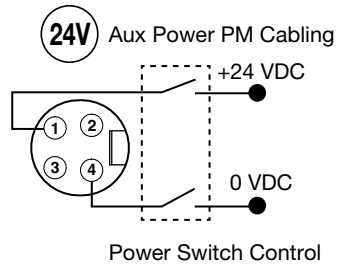
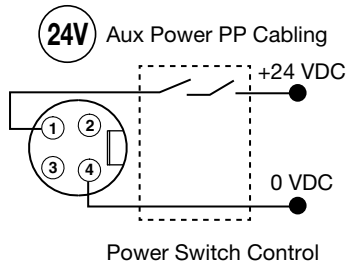

Pin Number	Address
1	AUX+
2	*L+
3	*L-
4	AUX-

Class B

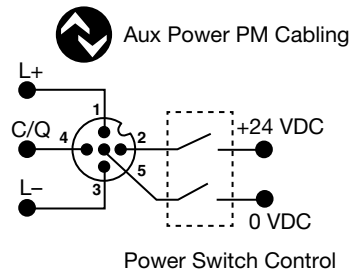
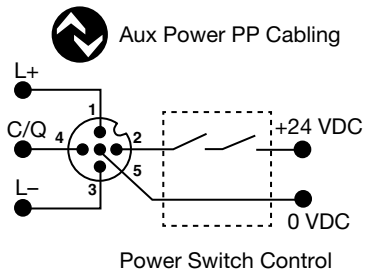

Pin Number	Address
1	L+
2	AUX+
3	L-
4	C/Q
5	AUX-

* 7/8" logic power has no connection to internal P2H unit but does carryover to OUT 7/8" connector (for jumper logic power only). Logic power for P2H unit will be supplied from M12 (pin 1 & 3).

D
 Subbase & Manual Valves
 H Series Micro
 Moduteflex Series
 H Series ISO
 Network Connectivity
 DX ISOMAX Series
 Valvair II Series



For inventory, lead times, and kit lookup, visit www.pdnplu.com

P2H IO-Link Node 24 DO – Input / Output Data Mapping

Input Data

One byte of diagnostic input data is transferred from Moduflex to the IO-Link Master.

Process Input Data

7	6	5	4	3	2	1	0
Output driver SPI error	Output driver channel error	Polyfuse tripped	Temperature warning	SPI error	Aux voltage error	Aux voltage warning	Acknowledge required

Diag bit	Error Message	Detail
Diag 0	Fail-safe status	Acknowledgment required
Diag 1	Auxiliary voltage warning	Auxiliary voltage out of range, check auxiliary power line
Diag 2	Auxiliary voltage failure	Auxiliary voltage out of order, check auxiliary power source
Diag 3	Module failure	Switch OFF / ON auxiliary power, if error message persists, replace the module
Diag 4	Module over-temperature	Switch OFF / ON auxiliary power, if error message persists, replace the module
Diag 5	Module over-load	Check overall pilot solenoid valves, if error message persists, replace the module
Diag 6	Pilot solenoid(s) short circuit	Check faulty pilot solenoid valve(s), replace if necessary
Diag 7	Outputs stage not available	Auxiliary power is OFF

Output Data

Three bytes of process data are received by Moduflex from the IO-Link Master for control of solenoids.

Process Output Data (Byte 0)

7	6	5	4	3	2	1	0
EV8	EV7	EV6	EV5	EV4	EV3	EV2	EV1

Process Output Data (Byte 1)

7	6	5	4	3	2	1	0
EV16	EV15	EV14	EV13	EV12	EV11	EV10	EV9

Process Output Data (Byte 2)

7	6	5	4	3	2	1	0
EV24	EV23	EV22	EV21	EV20	EV19	EV18	EV17

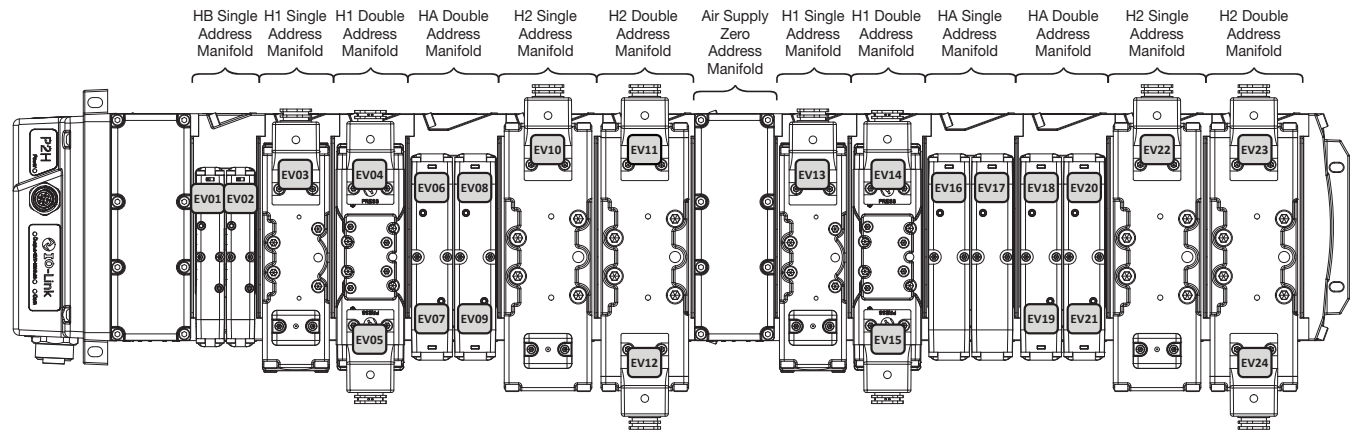

PLC Process outputs data mapping

Byte 0	7 0 EV08 EV01
Byte 1	EV16 EV09
Byte 2	EV24 EV17

Configuration IODD File

IODD file can be downloaded from IODD Finder or the P2H IO-Link web site:

- <https://ioddfinder.io-link.com>
- www.parker.com/pdn/P2H_IOL



For inventory, lead times, and kit lookup, visit www.pdnplu.com

D175

Parker Hannifin Corporation
 Pneumatic Division
 Richland, Michigan
www.parker.com/pneumatics

D

Subbase & Manual Valves

H Series Micro

Moduflex Series

H Series ISO

Network Connectivity

DX ISOMAX Series

Valvair II Series

Features

P2H Ethernet Node 32 DO

The P2H Ethernet Node has been designed to be connected to a many popular Ethernet Networks. It can be used with Parker’s H-Universal ISO 15407-2 (size 02 & 01) and 5599-2 (sizes 1, 2 & 3) valve series. It can control up to 32 pilot solenoid addresses with different power configuration options available and provides local visual and remote diagnostics through the Network. Designed for industrial environments, the P2H Ethernet Node is constructed of PBT material, which is glass-filled and offers weld splatter resistance, UV stability and has significant flame-retardant properties making it suitable for the durability required in industrial applications with high heat and welding applications.

Features

Industrial Ethernet Protocols:

- EtherNet/IP
- Profinet
- EtherCAT
- Modbus TCP
- Powerlink

Power Options:

- Power IN/OUT Connection
- 7/8 4 pin
- 7/8 5 pin
- L- Code M12 5 pin
- Safe Power Capable
- OSSD Compatible

Environment:

- IP65
- Weld Spatter Resistant
- Weld Noise Immune

Diagnostics:

- PLC
- Web Interface
- Network Specific LED’s

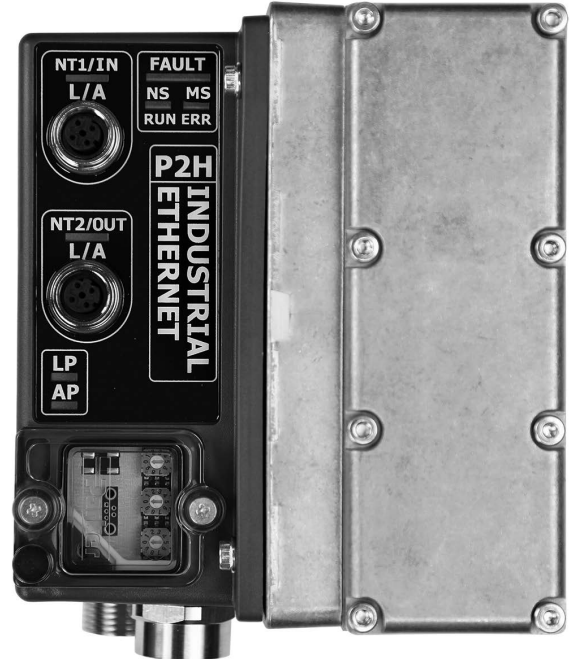
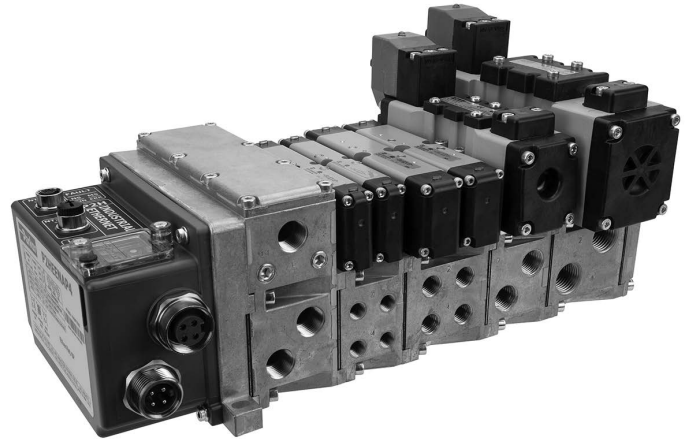

D	Subbase & Manual Valves	H Series Micro	Modulflex Series	H Series ISO	Network Connectivity	DX ISOMAX Series	Valvair-II Series
---	-------------------------	----------------	------------------	--------------	----------------------	------------------	-------------------



For inventory, lead times, and kit lookup, visit www.pdnplu.com

D176

Parker Hannifin Corporation
 Pneumatic Division
 Richland, Michigan
www.parker.com/pneumatics

Ordering Information

P2H Ethernet Node 32 DO - Popular Module Combinations

- Listed below are popular module configurations
- For full model number structure, please refer to next page

EtherNet/IP™

Popular Part Number Configurations				
Pilot Type	Thread Type	Power Source for Output 25-32	Power Connector	End Plate Part Number
Internal	NPT	Aux Power	7/8" 4-pin power IN/OUT with 1 safe power capable zone	PSHU20P200PE000A-P4
Internal	NPT	Logic Power Isolated from Aux Power	7/8" 4-pin power IN/OUT with 1 safe power capable zone	PSHU20P200PE000L-P4
Internal	NPT	Aux Power	7/8" 5-pin power IN/OUT with 1 safe power capable zone	PSHU20P200PE000A-P5
Internal	NPT	Logic Power Isolated from Aux Power	7/8" 5-pin power IN/OUT with 1 safe power capable zone	PSHU20P200PE000L-P5
Internal	NPT	Aux Power	M12 L-Coded, 5-pin power IN/OUT with 1 safe power capable zone	PSHU20P200PE000A-L5
Internal	NPT	Logic Power Isolated from Aux Power	M12 L-Coded, 5-pin power IN/OUT with 1 safe power capable zone	PSHU20P200PE000L-L5



Popular Part Number Configurations				
Pilot Type	Thread Type	Power Source for Output 25-32	Power Connector	End Plate Part Number
Internal	NPT	Aux Power	7/8" 4-pin power IN/OUT with 1 safe power capable zone	PSHU20P200PN000A-P4
Internal	NPT	Logic Power Isolated from Aux Power	7/8" 4-pin power IN/OUT with 1 safe power capable zone	PSHU20P200PN000L-P4
Internal	NPT	Aux Power	7/8" 5-pin power IN/OUT with 1 safe power capable zone	PSHU20P200PN000A-P5
Internal	NPT	Logic Power Isolated from Aux Power	7/8" 5-pin power IN/OUT with 1 safe power capable zone	PSHU20P200PN000L-P5
Internal	NPT	Aux Power	M12 L-Coded, 5-pin power IN/OUT with 1 safe power capable zone	PSHU20P200PN000A-L5
Internal	NPT	Logic Power Isolated from Aux Power	M12 L-Coded, 5-pin power IN/OUT with 1 safe power capable zone	PSHU20P200PN000L-L5

EtherCAT®

Popular Part Number Configurations				
Pilot Type	Thread Type	Power Source for Output 25-32	Power Connector	End Plate Part Number
Internal	NPT	Aux Power	7/8" 4-pin power IN/OUT with 1 safe power capable zone	PSHU20P200PT000A-P4
Internal	NPT	Logic Power Isolated from Aux Power	7/8" 4-pin power IN/OUT with 1 safe power capable zone	PSHU20P200PT000L-P4
Internal	NPT	Aux Power	7/8" 5-pin power IN/OUT with 1 safe power capable zone	PSHU20P200PT000A-P5
Internal	NPT	Logic Power Isolated from Aux Power	7/8" 5-pin power IN/OUT with 1 safe power capable zone	PSHU20P200PT000L-P5
Internal	NPT	Aux Power	M12 L-Coded, 5-pin power IN/OUT with 1 safe power capable zone	PSHU20P200PT000A-L5
Internal	NPT	Logic Power Isolated from Aux Power	M12 L-Coded, 5-pin power IN/OUT with 1 safe power capable zone	PSHU20P200PT000L-L5



For inventory, lead times, and kit lookup, visit www.pdnplu.com

D177

Parker Hannifin Corporation
Pneumatic Division
Richland, Michigan
www.parker.com/pneumatics

D

Subbase & Manual Valves

H Series Micro

Modulflex Series

H Series ISO

Network Connectivity

DX ISOMAX Series

Valvair II Series

Ordering Information

P2H Ethernet Node 32 DO - Overview

Designed to integrate directly with all H Series ISO valve sizes, the P2H Ethernet Network Node provides a compact, robust and cost-efficient solution for industrial ethernet connectivity to a PLC or other controls device that supports industrial ethernet protocols. The P2H Ethernet Network Node is offered as an end plate kit on the H Series valve for five sizes (HB, HA, H1, H2 and H3). The P2H Ethernet Network Node is suitable for use on a valve manifold with up to 32 solenoid outputs. P2H Ethernet Node connects to a network with two standard M12 D-coded connections. These two connections function as a switch to enable the network to be connected to another network device.

Power connectors are available in three styles:

- 7/8 4-pin
- 7/8 5-pin
- M12 L-Code 5-pin

The power connectors are arranged in an IN/OUT design, and this allows the flexibility to connect power to another down stream device, instead of running two separate cables from a power supply. Each power connector can supply up to 12 A of current on both Logic and Auxiliary power pins. All power connections support (OSSD) test pulsing if the P2H Ethernet Node is connected to a safety rated output device that uses test pulses to detect faults in a safety system.

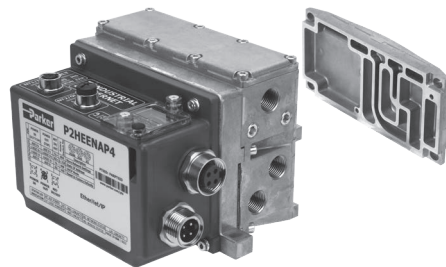

PSHU20 P2 0 0 P E 000 A - P4

Valve Type	
Plug-in (Internal pilot)	PSHU20
Plug-in (External pilot)	PSHU2X

Thread Type	
NPT	0
BSPP "G"	1

Network Connections	
EtherNet/IP™	E
EtherCAT	T
PROFINET	N
Modbus TCP	M
Powerlink	W

Power Connector	
7/8 4-pin Power IN/OUT with 1 Safe Power Capable Zone	P4
7/8 5-pin Power IN/OUT with 1 Safe Power Capable Zone	P5
M12 L-Code 5-pin IN/OUT with 1 Safe Power Capable Zone	L5

Right Hand End Plate Type / Thread Size	
Low profile (no ports)	0
1/2 Exhaust and Inlet Port	1
3/4 Exhaust and Inlet Port	2
H3 Transition Plate and End Plate (electrical pass through for plug-in valves only)	3
H3 Transition Plate and End Plate (expansion to 25th address for plug-in valves only)	4

Expansion Module / Power Source	
Power Source for Output 25-32: AUX Power	A
Power Source for Output 25-32: Logic Power	L

D

Subbase & Manual Valves

H Series Micro

Modulflex Series

H Series ISO

Network Connectivity

DX ISOMAX Series

Valvair-II Series



For inventory, lead times, and kit lookup, visit www.pdnplu.com

P2H Ethernet Node 32 DO - Expansion Module

Note: An optional intermediate air supply module must be installed to the manifold for expansion from 25 – 32 solenoids, 24 to 31 addresses.

PSHU115A E 1 P

Mounting Style / Port Size	
Intermediate Air Supply, NPT / Internal Pilot	PSHU115A
Intermediate Air Supply, BSPP / Internal Pilot	PSHU115B*
Intermediate Air Supply, NPT / External Pilot	PSHU115C
Intermediate Air Supply, BSPP / External Pilot	PSHU115D*

* BSPP conforms to ISO 1179-1 w 228-1 threads.

Gasket Options	
1	1,3,5 Ports Open And Pilots Open
2	1,3,5 Ports Closed And Pilots Open
3	1 Closed, 3,5 Ports Open And Pilots Open
4	1 Port Open, 3,5 Ports Closed And Pilots Open
5	1,3,5 Ports Open And Pilots Closed
6	1,3,5 Ports Closed And Pilots Closed
7	1 Closed, 3,5 Ports Open And Pilots Closed
8	1 Port Open, 3,5 Ports Closed And Pilots Closed

Circuit Board Address Configuration	
E	With Electrical Expansion To 24th Address



Intermediate air supply module shown

Address Numbers

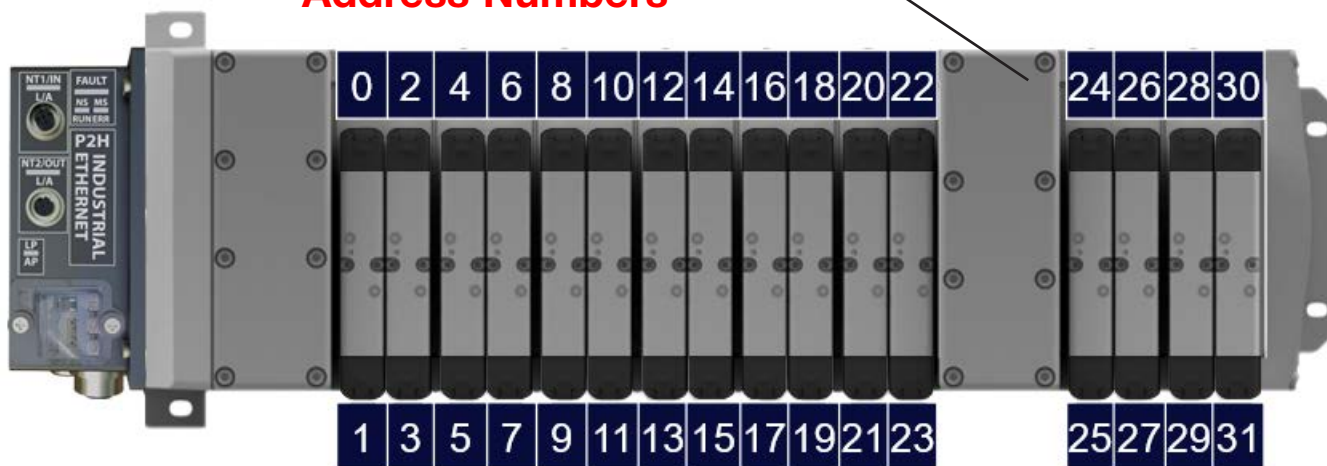

D
Subbase & Manual Valves
H Series Micro
Modulflex Series
H Series ISO
Network Connectivity
DX ISOMAX Series
Valvair II Series

Ordering Information

P2H Ethernet Node 32 DO - Network Interface

The P2H Node 32DO allows connection to an industrial Ethernet Network via two M-12 D-Coded connectors (NT1 and NT2). An embedded switch allows for daisy-chaining ethernet communications. The connectors pin assignments are as follows:

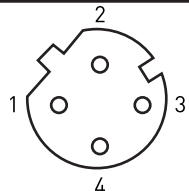
M12, D-coded, Female	Pin No.	Function
	1	Tx+
	2	Rx+
	3	Tx-
	4	Rx-

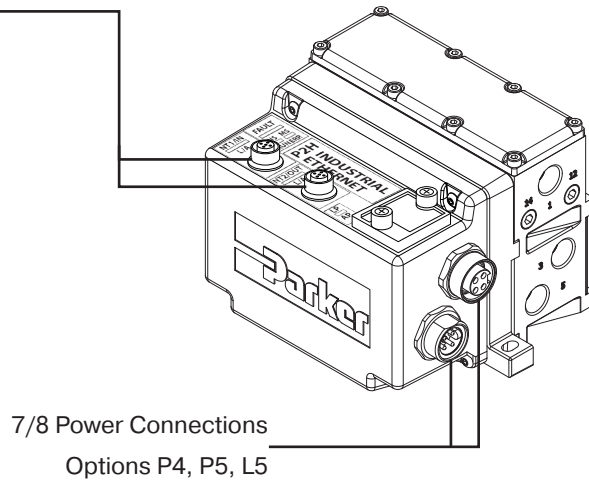

D

Industrial Ethernet Options



Network Connections	
EtherNet/IP™	E
EtherCAT	T
PROFINET	N
Modbus TCP	M
Powerlink	W

Subbase & Manual Valves
 H Series Micro
 Modulflex Series
 H Series ISO
 Network Connectivity
 DX ISOMAX Series
 Valvair II Series



For inventory, lead times, and kit lookup, visit www.pdnplu.com

D180

Parker Hannifin Corporation
 Pneumatic Division
 Richland, Michigan
www.parker.com/pneumatics

P2H Ethernet Node 32 DO - Power Options

- The P2H Ethernet Network Node has 3 available power connectors
- There are two power schemes that can be achieved detailed below
- H ISO Universal manifold valves draw power from the AUX power pins of the power connector

Consumption @ 24 VDC

AUX power max consumption	12A
Logic power max consumption	12A

Left over power that is not used by the P2H Ethernet Node can be passed on to other devices in the system through the power OUT connector



Power Connector *	
7/8 4-pin power in/out with 1 safe power capable zone	P4
7/8 5-pin power in/out with 1 safe power capable zone	P5
M12 L-Code 5-Pin in/out with 1 Safe Power Capable zone	L5

Power Connection Layout

The following three types of power connectors are available based on the end user's requirement. Current considerations should be used in the power connection selection process. Each power connection type can support a maximum of 12 A of current on each channel (VAUX and VLOG). When daisy chaining power is used, care must be taken in knowing the downstream current draw in order not to overload the maximum current rating of the pins.

	P4 - 7/8", 4-pin	P5 - 7/8", 5-pin	L5 - L-Coded, M12																																																			
TOP CONNECTOR	Power OUT	Power OUT	Power OUT																																																			
	<table border="1"> <thead> <tr> <th>Pin</th> <th>Function</th> <th>Description</th> </tr> </thead> <tbody> <tr> <td>1</td> <td>+ 24 V</td> <td>V2 (VAUX)</td> </tr> <tr> <td>2</td> <td>+ 24 V</td> <td>V1 (VLOG)</td> </tr> <tr> <td>3</td> <td>0 V</td> <td>GND V1 (VLOG)</td> </tr> <tr> <td>4</td> <td>0 V</td> <td>GND V2 (VAUX)</td> </tr> </tbody> </table>	Pin	Function	Description	1	+ 24 V	V2 (VAUX)	2	+ 24 V	V1 (VLOG)	3	0 V	GND V1 (VLOG)	4	0 V	GND V2 (VAUX)	<table border="1"> <thead> <tr> <th>Pin</th> <th>Function</th> <th>Description</th> </tr> </thead> <tbody> <tr> <td>1</td> <td>0 V</td> <td>GND V2 (VAUX)</td> </tr> <tr> <td>2</td> <td>0 V</td> <td>GND V1 (VLOG)</td> </tr> <tr> <td>3</td> <td>PE</td> <td>Protective Earth</td> </tr> <tr> <td>4</td> <td>+ 24 V</td> <td>V1 (VLOG)</td> </tr> <tr> <td>5</td> <td>+ 24 V</td> <td>V2 (VAUX)</td> </tr> </tbody> </table>	Pin	Function	Description	1	0 V	GND V2 (VAUX)	2	0 V	GND V1 (VLOG)	3	PE	Protective Earth	4	+ 24 V	V1 (VLOG)	5	+ 24 V	V2 (VAUX)	<table border="1"> <thead> <tr> <th>Pin</th> <th>Function</th> <th>Description</th> </tr> </thead> <tbody> <tr> <td>1</td> <td>+ 24 V</td> <td>V1 (VLOG)</td> </tr> <tr> <td>2</td> <td>0 V</td> <td>GND V2 (VAUX)</td> </tr> <tr> <td>3</td> <td>0 V</td> <td>GND V1 (VLOG)</td> </tr> <tr> <td>4</td> <td>+ 24 V</td> <td>V2 (VAUX)</td> </tr> <tr> <td>5</td> <td>PE</td> <td>Protective Earth</td> </tr> </tbody> </table>	Pin	Function	Description	1	+ 24 V	V1 (VLOG)	2	0 V	GND V2 (VAUX)	3	0 V	GND V1 (VLOG)	4	+ 24 V	V2 (VAUX)	5	PE	Protective Earth
	Pin	Function	Description																																																			
	1	+ 24 V	V2 (VAUX)																																																			
2	+ 24 V	V1 (VLOG)																																																				
3	0 V	GND V1 (VLOG)																																																				
4	0 V	GND V2 (VAUX)																																																				
Pin	Function	Description																																																				
1	0 V	GND V2 (VAUX)																																																				
2	0 V	GND V1 (VLOG)																																																				
3	PE	Protective Earth																																																				
4	+ 24 V	V1 (VLOG)																																																				
5	+ 24 V	V2 (VAUX)																																																				
Pin	Function	Description																																																				
1	+ 24 V	V1 (VLOG)																																																				
2	0 V	GND V2 (VAUX)																																																				
3	0 V	GND V1 (VLOG)																																																				
4	+ 24 V	V2 (VAUX)																																																				
5	PE	Protective Earth																																																				
BOTTOM CONNECTOR	Power IN	Power IN	Power IN																																																			
	<table border="1"> <thead> <tr> <th>Pin</th> <th>Function</th> <th>Description</th> </tr> </thead> <tbody> <tr> <td>1</td> <td>+ 24 V</td> <td>V2 (VAUX)</td> </tr> <tr> <td>2</td> <td>+ 24 V</td> <td>V1 (VLOG)</td> </tr> <tr> <td>3</td> <td>0 V</td> <td>GND V1 (VLOG)</td> </tr> <tr> <td>4</td> <td>0 V</td> <td>GND V2 (VAUX)</td> </tr> </tbody> </table>	Pin	Function	Description	1	+ 24 V	V2 (VAUX)	2	+ 24 V	V1 (VLOG)	3	0 V	GND V1 (VLOG)	4	0 V	GND V2 (VAUX)	<table border="1"> <thead> <tr> <th>Pin</th> <th>Function</th> <th>Description</th> </tr> </thead> <tbody> <tr> <td>1</td> <td>0 V</td> <td>GND V2 (VAUX)</td> </tr> <tr> <td>2</td> <td>0 V</td> <td>GND V1 (VLOG)</td> </tr> <tr> <td>3</td> <td>PE</td> <td>Protective Earth</td> </tr> <tr> <td>4</td> <td>+ 24 V</td> <td>V1 (VLOG)</td> </tr> <tr> <td>5</td> <td>+ 24 V</td> <td>V2 (VAUX)</td> </tr> </tbody> </table>	Pin	Function	Description	1	0 V	GND V2 (VAUX)	2	0 V	GND V1 (VLOG)	3	PE	Protective Earth	4	+ 24 V	V1 (VLOG)	5	+ 24 V	V2 (VAUX)	<table border="1"> <thead> <tr> <th>Pin</th> <th>Function</th> <th>Description</th> </tr> </thead> <tbody> <tr> <td>1</td> <td>+ 24 V</td> <td>V1 (VLOG)</td> </tr> <tr> <td>2</td> <td>0 V</td> <td>GND V2 (VAUX)</td> </tr> <tr> <td>3</td> <td>0 V</td> <td>GND V1 (VLOG)</td> </tr> <tr> <td>4</td> <td>+ 24 V</td> <td>V2 (VAUX)</td> </tr> <tr> <td>5</td> <td>PE</td> <td>Protective Earth</td> </tr> </tbody> </table>	Pin	Function	Description	1	+ 24 V	V1 (VLOG)	2	0 V	GND V2 (VAUX)	3	0 V	GND V1 (VLOG)	4	+ 24 V	V2 (VAUX)	5	PE	Protective Earth
	Pin	Function	Description																																																			
	1	+ 24 V	V2 (VAUX)																																																			
2	+ 24 V	V1 (VLOG)																																																				
3	0 V	GND V1 (VLOG)																																																				
4	0 V	GND V2 (VAUX)																																																				
Pin	Function	Description																																																				
1	0 V	GND V2 (VAUX)																																																				
2	0 V	GND V1 (VLOG)																																																				
3	PE	Protective Earth																																																				
4	+ 24 V	V1 (VLOG)																																																				
5	+ 24 V	V2 (VAUX)																																																				
Pin	Function	Description																																																				
1	+ 24 V	V1 (VLOG)																																																				
2	0 V	GND V2 (VAUX)																																																				
3	0 V	GND V1 (VLOG)																																																				
4	+ 24 V	V2 (VAUX)																																																				
5	PE	Protective Earth																																																				

*PE – Protective Earth



For inventory, lead times, and kit lookup, visit www.pdnplu.com

D181

Parker Hannifin Corporation
 Pneumatic Division
 Richland, Michigan
www.parker.com/pneumatics

D

Subbase & Manual Valves

H Series Micro

Moduflex Series

H Series ISO

Network Connectivity

DX ISOMAX Series

Valvair II Series

Ordering Information

P2H Ethernet Node 32 DO - Power Scheme 1 Option "A"

- All 32 addresses are controlled in the same power zone
- Safety zoning is possible for valve solenoids and, with the H ISO Universal valves, pneumatic pressure
- Power zone is safe power capable

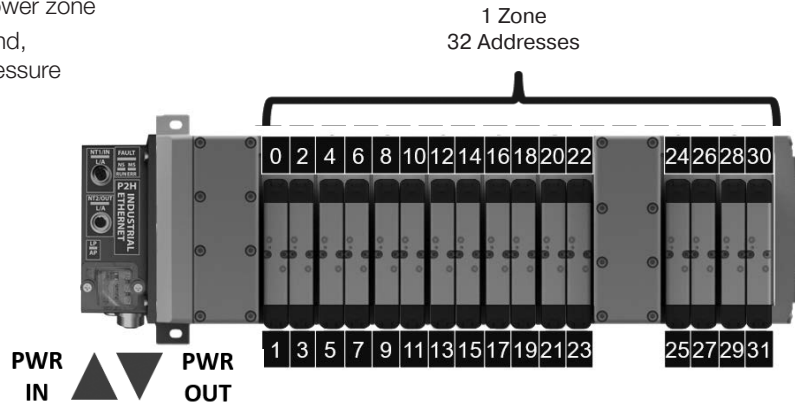

Power Scheme 2 Option "L"

- The 1st 24 addresses are supplied by axillary voltage power. The last 8 addresses are supplied by the logic voltage power.
- Each zone has an isolated safe ground pin so each can be powered by a SAFE 24 VDC auxiliary source in PP or PM mode. **NOTE:** You can treat each zone as a separate power zone/safe zone. Be aware that the last 8 addresses will be supplied by logic power. If power is shut down to this zone the P2H Ethernet module loses power and communication. This may cause extra time to reconnect to the network when power is restored.

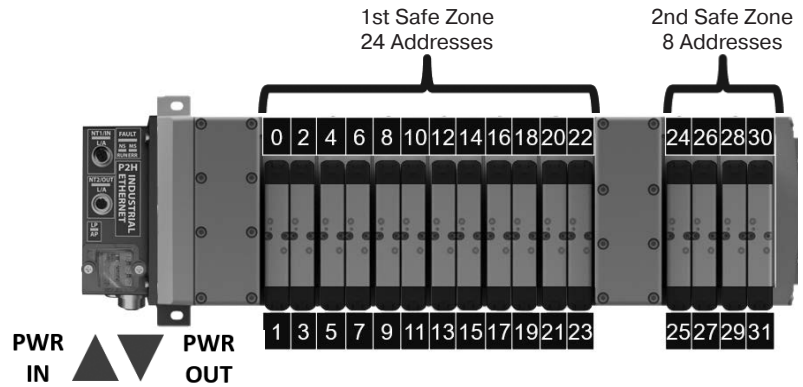

Industrial Ethernet Options

XXXXXX P2 X X P X 000 A - XX

Expansion Module / Power Source	
Power Source for Output 25-32: AUX Power	A
Power Source for Output 25-32: Logic Power	L

D	Subbase & Manual Valves
H Series Micro	Modulflex Series
H Series ISO	Network Connectivity
DX ISOMAX Series	Valvair-II Series



For inventory, lead times, and kit lookup, visit www.pdnplu.com

D182

Parker Hannifin Corporation
Pneumatic Division
Richland, Michigan
www.parker.com/pneumatics

P2H Ethernet Node 32 DO - Safe Power Connectivity



P2H Ethernet Node connection to SAFE Power PP / PM mode for valve control

The P2H Ethernet Node 32DO Auxiliary Power for valves can be supplied from an OSSD (Output Signal Switching Device) 24 VDC safe output power source in PP (plus plus) or PM (plus minus) configurations. The connection diagram below represents power option "A". For power option "L" valve driver number 4 power would be supplied from the logic pins of the connection selected (please reference the power pinout diagram).

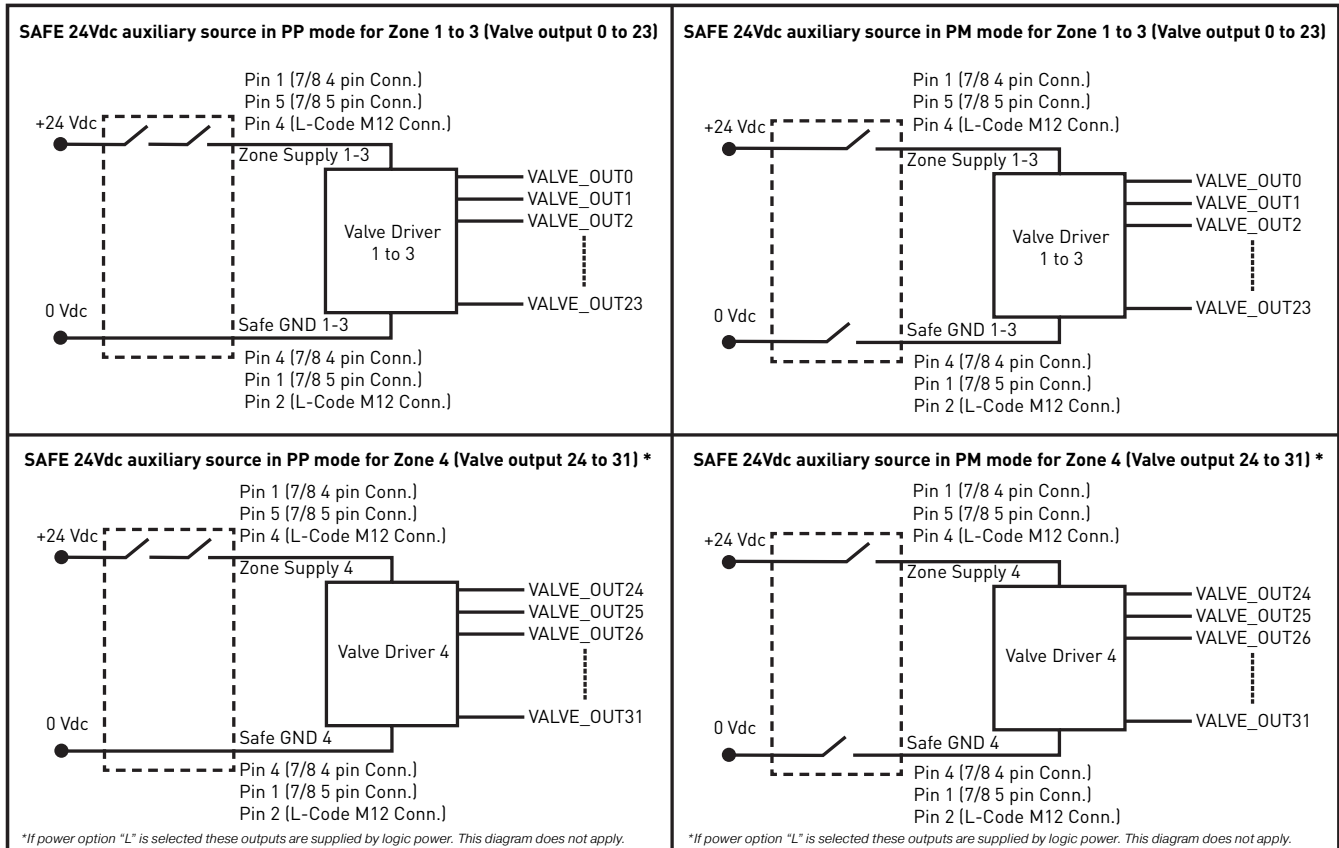

Note: Please check max. power available from the source. Refer to the ["Auxiliary power consumption calculation"](#) section.

* 7/8" logic power has no connection to internal P2H unit but does carryover to OUT 7/8" connector (for jumper logic power only). Logic power for P2H unit will be supplied from M12 (pin 1 & 3).



For inventory, lead times, and kit lookup, visit www.pdnplu.com

P2H Ethernet Node 32 DO - Auxiliary Power Consumption Calculation

The P2H Node 32DO auxiliary power consumption calculation depends on the combination of the valves selected and the number of coils used. The table below can be used for power consumption calculation by valve type and the number of each type used. Take note that there are two types of coils for sizes 1,2,3. An energy efficient coil and standard coil.

Valve Range	Number of Pilots Simultaneously powered	Power	Total
H ISO - 15407-2 - Sizes 02 & 01	_____	x 40 mA	= _____ mA
H ISO - 5599-2 - Sizes 1, 2 & 3 (Energy Efficiency Coils) *	_____	x 54 mA	= _____ mA
H ISO - 5599-2 - Sizes 1, 2 & 3 (Standard Coils) **	_____	x 133 mA	= _____ mA
		Total :	_____ mA

* F9 Valve Voltage Code

** B9 Valve Voltage Code

Power Supply Diagnostics

Power Supply Diagnostics through LED

The P2H Node 32DO monitors the logic and auxiliary power supply voltages and manages two levels of diagnostics: warning and error range. Status is indicated via LEDs located on the device. The range limits can be modified through parameter data. To restore default value (factory setting), refer to "Factory Reset Section" in the manual.

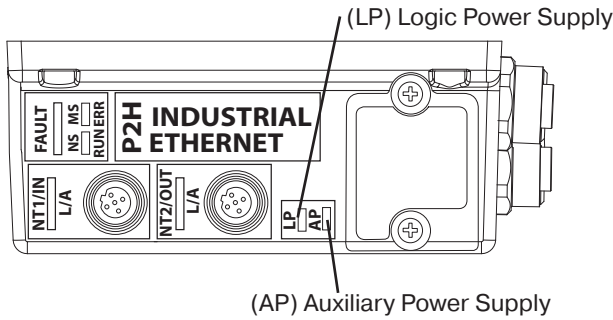

LP and AP (Green / Yellow) LEDs		
LED Status	Description	Troubleshooting
OFF	Logic and/or Aux lines not powered	Check power supply (see Power Supply section for pin assignments)
ON (Green)	Voltage in normal range	N/A
ON (Red)	Voltage in error range (too low or too high)	Check power supply (see Power Supply section for pin assignments)
Blinking (Red)	Voltage in warning range (out of normal range, not in error range)	Check power supply (see Power Supply section for pin assignments)
Blinking (Yellow)	Invalid rotary switch setting	Check rotary switch setting
Blinking (Red / Yellow)	Firmware version error or Completed "Reset to Factory" procedure	If switches setting different from "999" and no "Reset to Factory" performed via webpage, then contact technical support

LED function details:

- "Logic power" or "Aux power" error is active from 9.6 to 19.4 VDC or above 28.5 VDC
- When "Logic power error" or "Aux power error" is active, LED is solid red

Power Supply Diagnostics through Network and Process Data Mapping

Diagnostics are available in Process Input data (byte 0) to indicate whether Logic and Auxiliary voltages are within range. There is a warning range (normal operation with fault indication) and an error range (module enters Failsafe state).

The default warning range is set as 20.4 VDC < power supply < 26.4 VDC. These limits can be modified via acyclic data, objects # 11 and # 12. The error range is set as 19.4 VDC < power supply < 28.5 VDC. These limits cannot be modified.

The voltage measured by the module, both Logic and Auxiliary, can be accessed via acyclic data, in Object #4. The displayed value is in mV.

D
Subbase & Manual Valves
H Series Micro
Modulflex Series
H Series ISO
Network Connectivity
DX ISOMAX Series
Valvair II Series



For inventory, lead times, and kit lookup, visit www.pdnplu.com

P2H Ethernet Node 32 DO - Process Data mapping - Inputs

The following tables describes the input mapping for P2H Ethernet Node. The byte mapping order varies by protocol please reference the manual for specific byte order arrangement.

Channel Error – Input Mapping

Byte #	Input Bits								Description
	7	6	5	4	3	2	1	0	
1	EV07	EV06	EV05	EV04	EV03	EV02	EV01	EV00	Valve Error Data EVxx = Output on Valve range is 0 to 31
2	EV15	EV14	EV13	EV12	EV11	EV10	EV9	EV08	
3	EV23	EV22	EV21	EV20	EV19	EV18	EV17	EV16	
4	EV31	EV30	EV29	EV28	EV27	EV26	EV25	EV24	

Module Info Flags - Input Mapping

Byte #	Module Info Flags			
	Output Bits	Error Name	Error Description	
1	0	Heartbeat not toggling AUX 1	Heartbeat is currently not toggling	
	1	Heartbeat not toggling AUX 2		
	2	SPI COM Error AUX 1	Error in SPI Communication between AUX and Logic. Outputs are switched off	
	3	SPI COM Error AUX 2		
	4	SPI COM Lost AUX 1		
	1	5	SPI COM Lost AUX 2	Communication not possible. Outputs are switched off
		6	Output Interconnect Error	
7		SPI NP40 Error		
2	0	NP40 Version Error	Comm Module Version error. Outputs are switched off	
	1-7	Reserved	These bits will be always set as 0	

Module Error Input – Input Mapping

Byte #	Module Error Input		
	Output Bits	Error Name	Error Description
1	0	AUX Voltage Warning	Set if Auxiliary Voltage in warning range. Module keeps normal operation
	1	AUX Voltage Error	Auxiliary Voltage in Error range. Outputs are switched OFF
	2	Logic Voltage Warning	Set if Logic voltage is out of range for warning.
	3	Logic Voltage Error	Set if Logic voltage is out of range for error. Outputs are switched OFF
	4	Temperature Warning	Set if a temperature increase above warning levels is detected by the output drivers
	5	Output Driver Channel Error	Set if a major fault is detected at the output stage – solenoid short circuit. Outputs are switched OFF
	6	Module Error	Set if an internal communication error is active
2	7	Auxiliary Power Not Available	Auxiliary Power is off
	0 - 7	Reserved	These bits will be always set as 0

D
 Subbase & Manual Valves
 H Series Micro
 Moduflex Series
 H Series ISO
 Network Connectivity
 DX ISOMAX Series
 Valvair II Series



For inventory, lead times, and kit lookup, visit www.pdnplu.com

D185

Parker Hannifin Corporation
 Pneumatic Division
 Richland, Michigan
www.parker.com/pneumatics

P2H Ethernet Node 32 DO - Process Data mapping - Outputs

The following tables describes the input mapping for P2H Ethernet Node. The byte mapping order varies by protocol please reference the manual for specific byte order arrangement.

System Command – Output Mapping

Byte #	System Command Module								Description
	Output Bits								
	7	6	5	4	3	2	1	0	
1	System Command Value								One Byte that accepts the system command value see table below for values

Command Value	Command Name	Description
0X02	Store Switching Cycle Counters	When this command is executed, the current values of the switching cycle counters are stored into EEPROM. This command is intended to be used before powering off the device.
0X03	Store Diagnostic Log	When this command is executed, the diagnostic log is stored to the EEPROM.
0X04	Delete Diagnostic Log	Removes all diagnostic log entries in EEPROM (required by webpage).

Solenoids – Output Mapping

Byte #	Solenoid Module								Description
	Output Bits								
	7	6	5	4	3	2	1	0	
1	EV07	EV06	EV05	EV04	EV03	EV02	EV01	EV00	Valve Output Data EVxx -> Output on Valve range is 0 to 31
2	EV15	EV14	EV13	EV12	EV11	EV10	EV9	EV08	
3	EV23	EV22	EV21	EV20	EV19	EV18	EV17	EV16	
4	EV31	EV30	EV29	EV28	EV27	EV26	EV25	EV24	

D
Subbase & Manual Valves
H Series Micro
Modulflex Series
H Series ISO
Network Connectivity
DX ISOMAX Series
Valvair II Series



For inventory, lead times, and kit lookup, visit www.pdnplu.com

P2H Ethernet Node 32 DO - Solenoid Addressing

- The P2H Ethernet Network Node can support up to 32 addresses as shown
- Addresses 25-31 can be accessed using an Intermediate Air Supply with Electric Expansion
- Each address is one solenoid

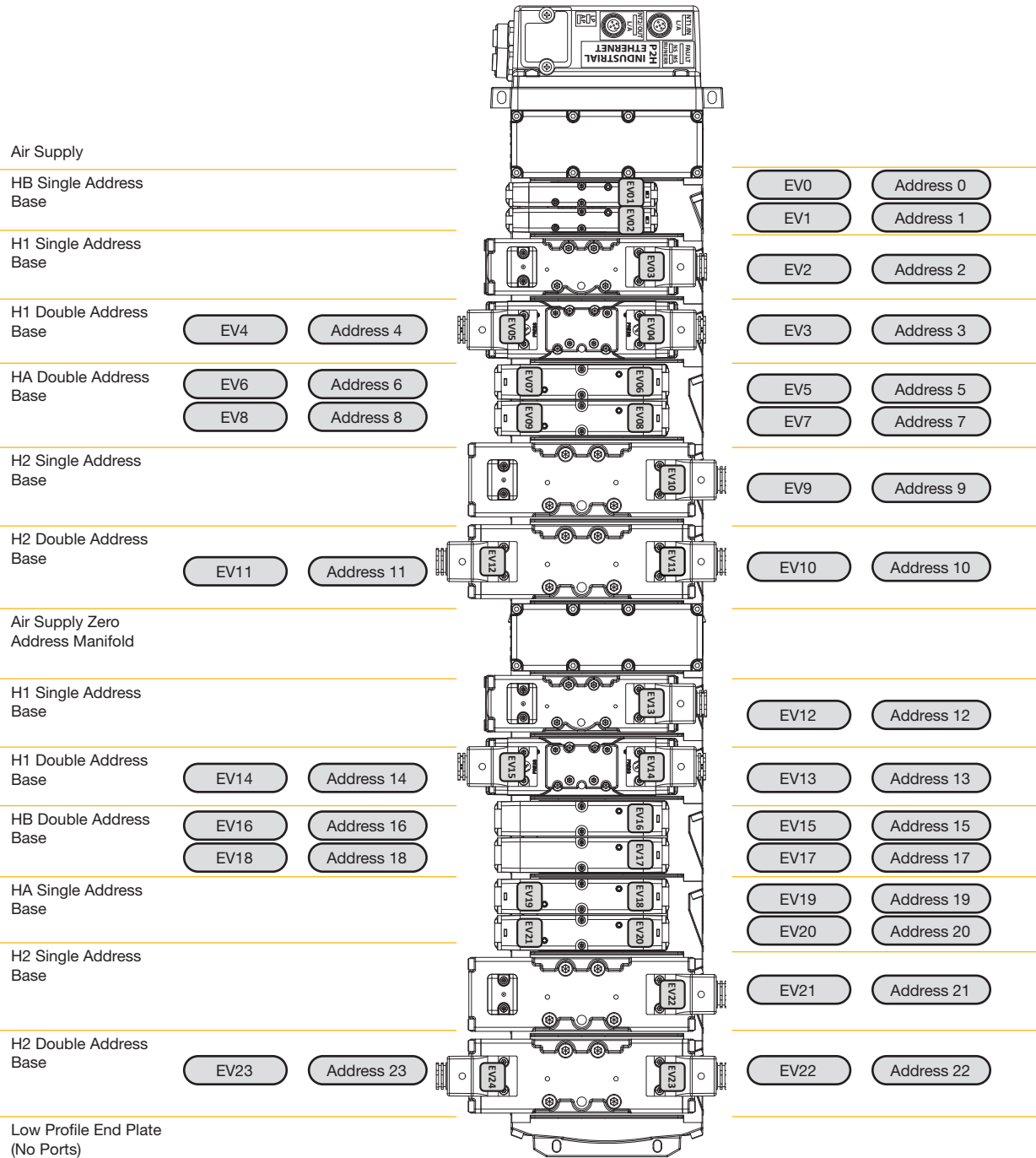

D

Subbase & Manual Valves

H Series Micro

Modulflex Series

H Series ISO

Network Connectivity

DX ISOMAX Series

Valvair II Series



For inventory, lead times, and kit lookup, visit www.pdnplu.com

D187

Parker Hannifin Corporation
Pneumatic Division
Richland, Michigan
www.parker.com/pneumatics

P2H Ethernet Node 32 DO - Technical Data

Mechanical Data

Housing Material	Housing /Enclosure: PBT with 33% GF and UL94-V0 Base Cover (plate): Aluminium 380
Enclosure rating	IP 65 (only when plugged-in and threaded-in)
Power Connectors	7/8" 4 pin or 7/8" 5 pin or L-Coded M12 5-pin male and female pin connector
Dimensions (L x B x H in mm)	226.6mm x 130.7mm x 55mm
Mounting type	Screw Mount
Ground strap attachment	M5
Weight	Approx. 1.3 kg

Electrical Data

Supply Voltage	24VDC (-15% to +20%)
Logic current at 24 V (V1)	Max Current 8A – Actual usage depends on configuration
Auxiliary current at 24 V (V2)	Max Current 12A – Actual usage depends on configuration

Valve Configuration

Compatible Valves	H Universal ISO Valves
-------------------	------------------------

Operating Conditions

Operating Temperature	0°C to 50°C
Storage Temperature	-25°C to 70°C
CE as per	IEC 61000-6-2 (Industrial Immunity) IEC 61000-6-4 (Industrial Emission)
Shock/Vibrations	IEC 60068-2-27:2008 IEC 60068-2-6:2007
Electrostatic Discharge	IEC 61000-4-2
Electrical Fast Transient/ Burst	IEC 61000-4-4
Surge Immunity	IEC 61000-4-5

D

Subbase & Manual Valves

H Series Micro

Moduflex Series

H Series ISO

Network Connectivity

DX ISOMAX Series

Valvair II Series



For inventory, lead times, and kit lookup, visit www.pdnplu.com

D188

Parker Hannifin Corporation
Pneumatic Division
Richland, Michigan
www.parker.com/pneumatics

P2H Ethernet Node 32 DO - H Series ISO Valves

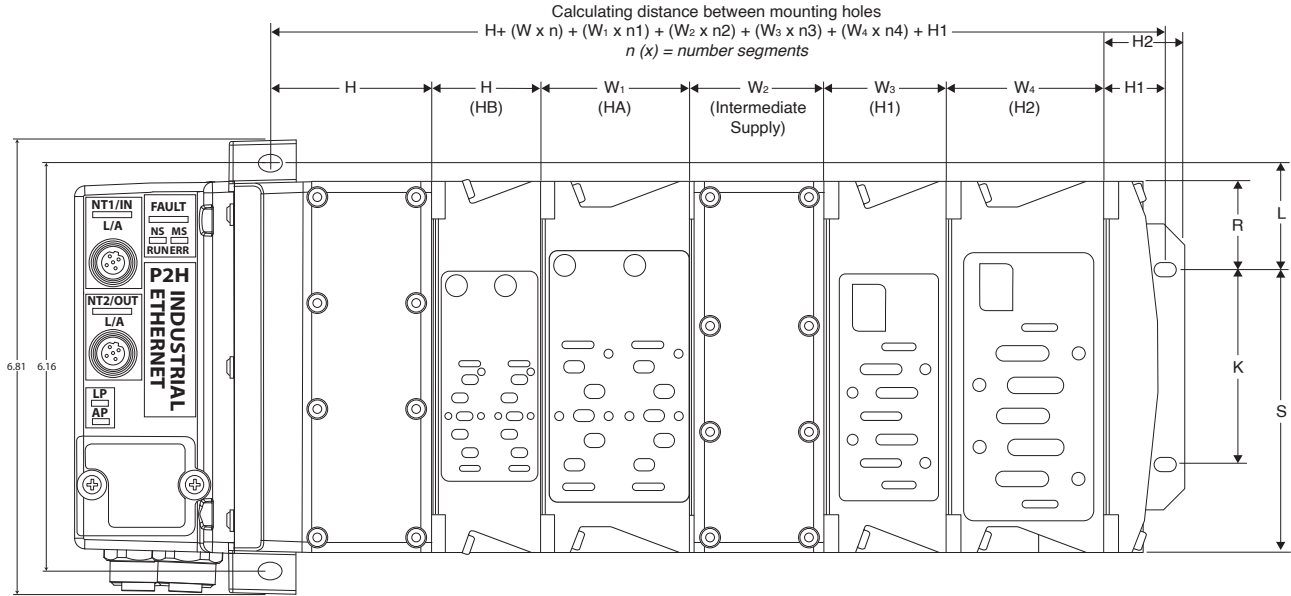

n (x) = number of segments

A	B	C	D	E	F	G	H	H ₁	H ₂	J	K	L
4.42 (112.3)	2.64 (67.1)	2.46 (62.5)	1.17 (29.7)	.55 (14)	9.32 (236.7)	1.51 (38.4)	2.36 (59.9)	.9 (22.9)	1.22 (31)	1.55 (39.4)	2.95 (74.9)	1.6 (40.6)
M	O	P	Q	R	S	T	W	W ₁	W ₂	W ₃	W ₄	
8.91 (226.3)	5.61 (142.5)	6.86 (174.2)	6.18 (157)	1.33 (33.8)	4.28 (108.7)	7.14 (181.4)	1.63 (41.4)	2.28 (57.9)	2.03 (51.6)	1.82 (46.2)	2.39 (60.7)	

Inches (mm)

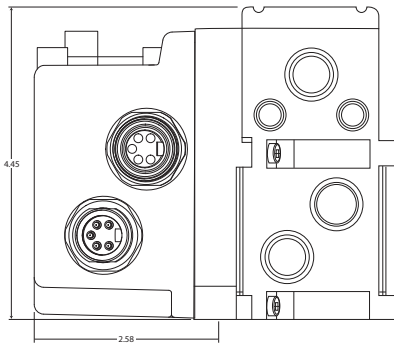

D

Subbase & Manual Valves

H Series Micro

Moduflex Series

H Series ISO

Network Connectivity

DX ISOMAX Series

Valvair II Series



For inventory, lead times, and kit lookup, visit www.pdnplu.com

D189

Parker Hannifin Corporation
Pneumatic Division
Richland, Michigan
www.parker.com/pneumatics

D
Subbase & Manual Valves
H Series Micro
Moduflex Series
H Series ISO
Network Connectivity
DXISOMAX Series
Valvair II Series



For inventory, lead times, and kit lookup, visit www.pdnplu.com

D190

Parker Hannifin Corporation
Pneumatic Division
Richland, Michigan
www.parker.com/pneumatics

Features

PCH Network Portal

Features

- Industrial Ethernet Communication
- Truly Configurable I/O
- Feature Rich Webserver
- Built-In Technician
- 3 Available Module Variants, 4 ports each
- Bluetooth Connectivity
- Flexible power connectors allowing daisy chain
- Certified to IP65 ingress protection
- Weld splatter resistant housing material
- Welding Noise Immune
- Safe Power Capable
- Built-in configurable IO-Link Master Ports

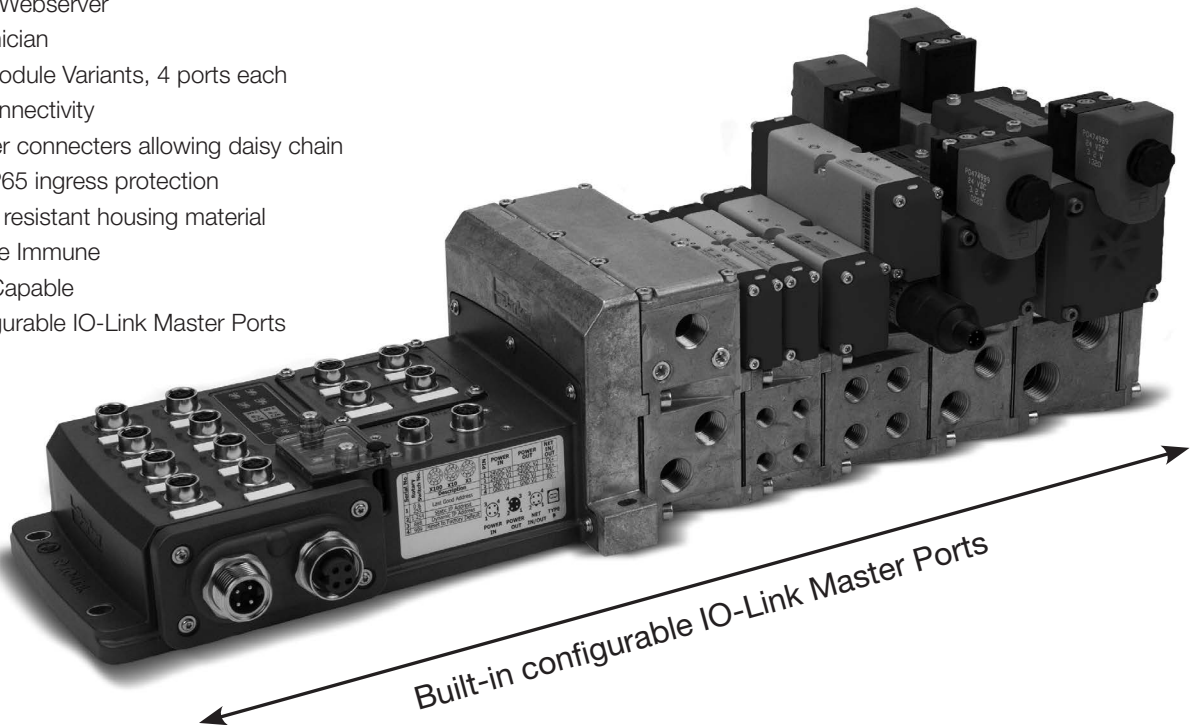

The PCH Network Portal redefines and revolutionizes decentralized machine I/O's architecture. The PCH Network Portal was engineered to support industrial ethernet protocols and the open protocol IO-Link with configurable inputs/outputs with true PNP/ NPN circuitry switching on each port for easy machine design changes. This integrated configurability gives the user flexibility in designing custom I/O architecture on the fly.

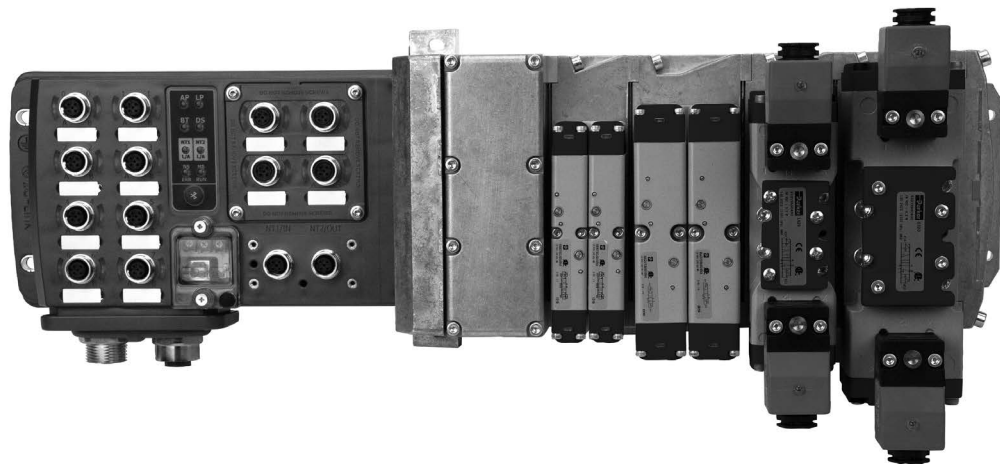

EtherNet/IP™

**PROFIBUS
INDUSTRIAL ETHERNET
NET**

EtherCAT®

**Modbus
TCP/IP**

The PCH Network Portal can be assembled to Parker's H ISO Universal Manifold Platform, giving you access to a wide variety of low ranges all on one manifold.



For inventory, lead times, and kit lookup, visit www.pdnplu.com

D191

Parker Hannifin Corporation
Pneumatic Division
Richland, Michigan
www.parker.com/pneumatics

D

Subbase & Manual Valves

H Series Micro

Modulflex Series

H Series ISO

Network Connectivity

DX ISOMAX Series

Valvair II Series

Features

Intuitive Interfaces

Modern factories recognize that plant floor architecture is an important structural part of machine design that can make a real difference in managing costs for future changes, integrations and expansions. The PCH Network Portal design team lived in this environment, therefore intuitive interfaces and complete modularity was the heart of PCH Network Portal design concepts.

As with all Cyber Physical Systems (CPS), intuitive interfaces are the backbone of simplicity in application. The PCH Network Portal offers several means of intuitive and embedded interfaces to shorten commission time.

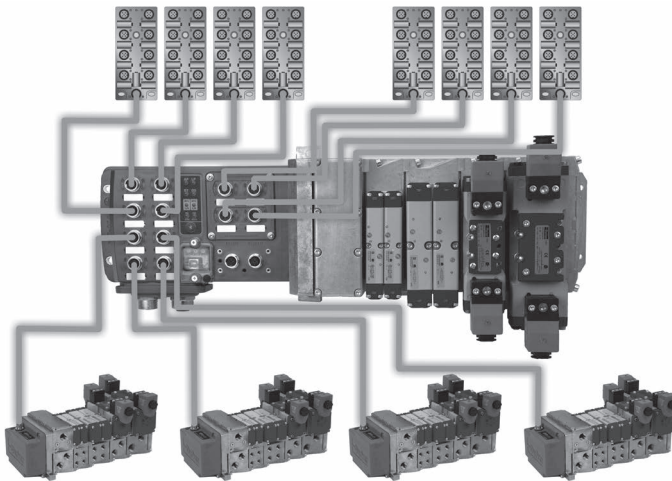
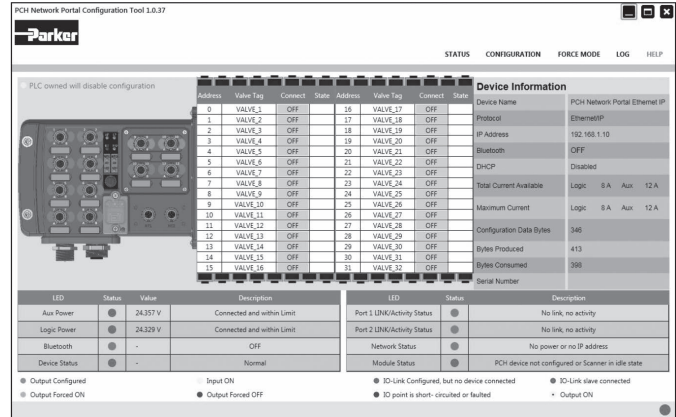

Value Redefined

The PCH Network Portal minimizes machine costs by redefining the traditional process of connectivity within a single footprint that provides multiple configurations. The flexibility of configurable I/O combined with built-in IO-Link master ports revolutionizes machine design and can save thousands of dollars at the design phase which typically accounts for 30-40% of overall costs. Changes can be made to the system with easy software reconfiguration of ports eliminating the need for additional hardware or time consuming programming.



Can't access the PLC? No Problem!

With meticulously designed embedded configuration tools, the PCH Network Portal can serve as your **virtual technician** to make problems easy to troubleshoot. A laptop, tablet or phone can access usable prognostic/diagnostic data and time stamped event logs to make accessing data and commissioning your machine simple. Once you've finished your configuration, the device's configuration profile can be downloaded and easily uploaded to other PCH Network Portals on your machine.

Configure via:

- Bluetooth App via phone or tablet
- Bluetooth connection via PC
- Integrated Webpage via ethernet connection
- Stand-a-lone "PCH Portal Configuration Tool" software via USB-B

Safety Foot Note:
Bluetooth application cannot turn on outputs if a PLC where present and in control. The application cannot override the PLC at any time.

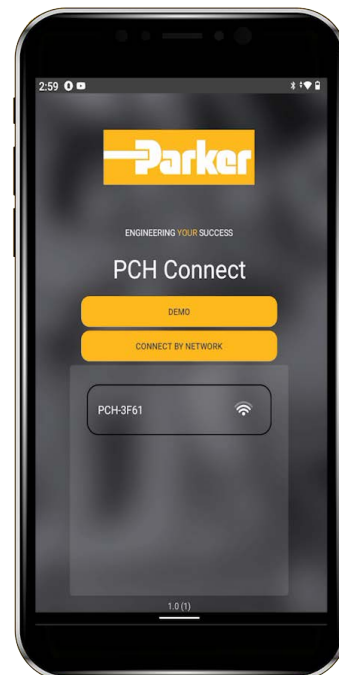

D
 Subbase & Manual Valves
 H Series Micro
 Modutex Series
 H Series ISO
 Network Connectivity
 DX ISOMAX Series
 Valvair-II Series



For inventory, lead times, and kit lookup, visit www.pdnplu.com

Features

Truly Configurable I/O

Configurable I/O means last minute design changes are now simple. Each PCH Network Portal is offered with three selectable modules that make up twelve configurable ports. All modules can be configured IO-Link A, IO-Link B or dual configurable I/O ports with true PNP/NPN circuitry switching on each port providing easy point and click changes on individual pins to customize a setup. Last minute design changes to the machine require minimal effort and no additional software or hardware. The ability to customize the machine design is no longer limited by the product.

H Series ISO & Network Connectivity PCH Network Portal

Port Config

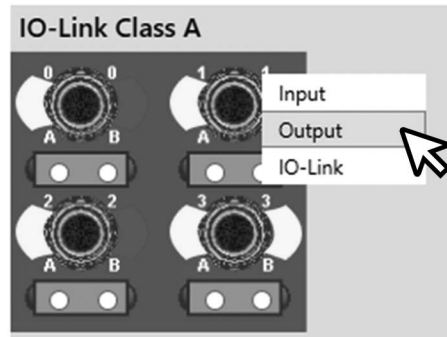

Tools Designed for Productivity

When a line stops and needs a reset you are often left wondering why. The root cause can seem a mystery and often stems back to over voltage or other power issues caused by the plant floor. Working with the PCH Network Portal is like having your own built-in technician. Rolling 40 errors, warnings and events are time and date stamped allowing you to spend time on what matters - running the facility. Let PCH Network Portal give you the detail so time can be better utilized elsewhere.

Built-In Technician

When using the 'PCH Portal Configuration Tool' your built-in technician comes to life with easy to follow screens for readouts, adjustments, and settings. Configuring the PCH Network Portal to the network is easy. Fast and storable configurations combined with embedded smart diagnostic and prognostic tools like built-in debounce times and up/down counters translate to quick change-over and short downtime. Further problems are easy to spot with the rolling 40 error, warnings, and events log which are time stamped. No more guessing at what went wrong in plant. Commissioning and troubleshooting a tool can even be done remotely from outside the work cell via the device's secure and lockable Bluetooth connectivity.

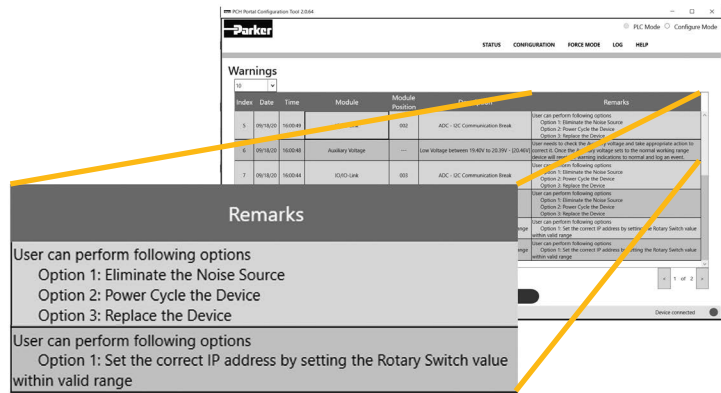

D
 Subbase & Manual Valves
 H Series Micro
 Modulflex Series
 H Series ISO
 Network Connectivity
 DX ISOMAX Series
 Valvair II Series



For inventory, lead times, and kit lookup, visit www.pdnplu.com

D193

Parker Hannifin Corporation
 Pneumatic Division
 Richland, Michigan
www.parker.com/pneumatics

Value Redefined

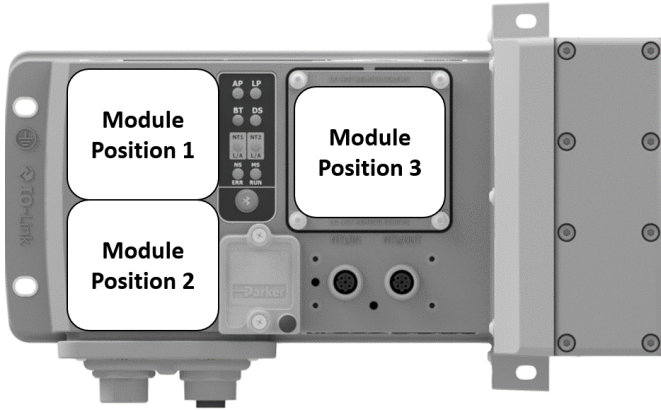

What are Module Positions?

- The PCH Network Portal is split into 3 Module Positions
- Each Module Position can accept different Module Variants to meet the application needs
- Populating a Module Position with an I/O Module Variant gives the PCH Network Portal 4 configurable M12 ports

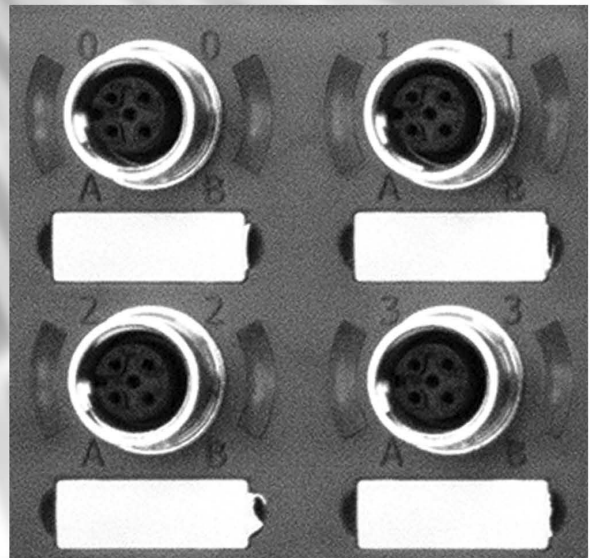
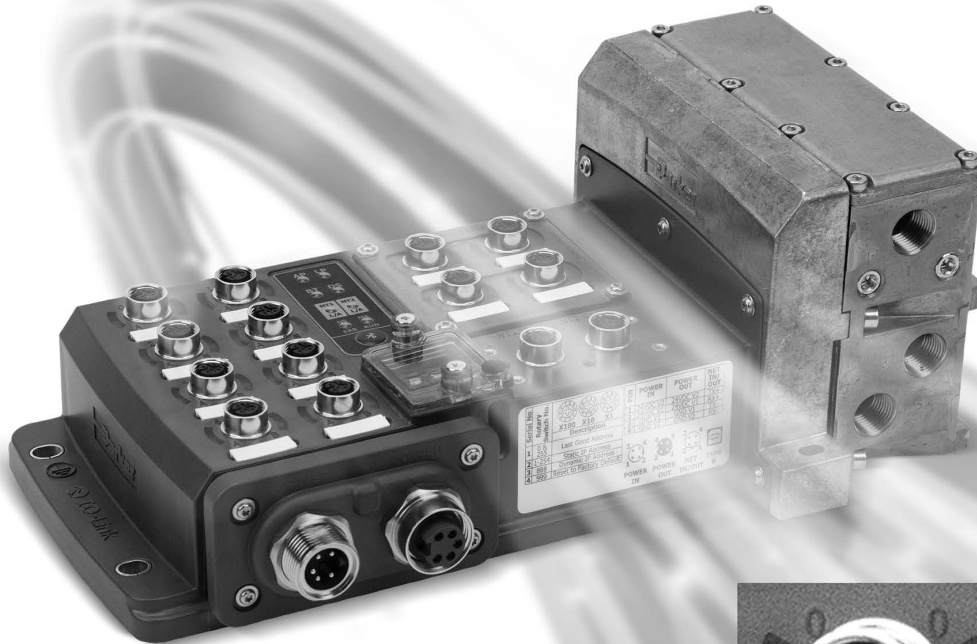

What is a Module Variant?

- 3 Module Variant are proposed offering each different capabilities (see details of Modules Variant A, B or C in next pages)
- A Module Variant offers 4 configurable M12 ports
- Depending on the Module Variant A, B or C selected, each M12 port can be individually configured differently between a variety of different behaviors

For Example

- With the Module Position 1 populated with Module Variant A, each M12 port can be individually configured as either IO-Link Class A Master or 2 Digital Inputs or 2 Digital Outputs
- A summary of the Module Variant offerings is on page D179

D	Subbase & Manual Valves
H Series Micro	Modulflex Series
H Series ISO	Network Connectivity
DX ISOMAX Series	
Valvair II Series	



For inventory, lead times, and kit lookup, visit www.pdnplu.com

Features

PCH Network Portal

Module Variants

Module
A

What is a Module Variant?

- The PCH Network Portal has 3 available Module Positions. Each module position can be populated with three different Module Variants
- Each Module Position can accept all module variants

Port Behavior

- Each port is capable of the following behavior listed below
- Through software, the user can click and change how the port behaves on the fly
- The A Module Variant gives the user access to IO-Link Class A Master ports

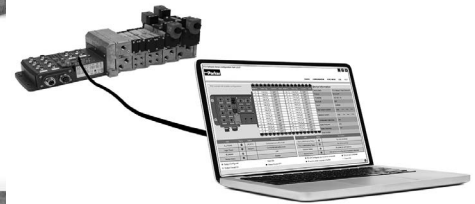

Possible Port Behavior

IO-Link, Class A Master or
2 x Digital Inputs or
2 x Digital Outputs*

IO-Link, Class A Master or
2 x Digital Inputs or
2 x Digital Outputs*

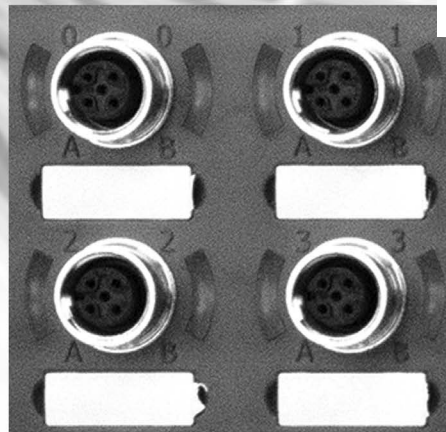

IO-Link, Class A Master or
2 x Digital Inputs or
2 x Digital Outputs*

IO-Link, Class A Master or
2 x Digital Inputs or
2 x Digital Outputs*

*Digital Output draws current from logic power

Port Behavior

- Each port's behavior can differ from one another
- For example, the user can select the behavior listed below through software (shown below)

IO-Link, Class A Master or
2 x Digital Inputs
2 x Digital Outputs

IO-Link, Class A Master or
2 x Digital Inputs or
2 x Digital Outputs

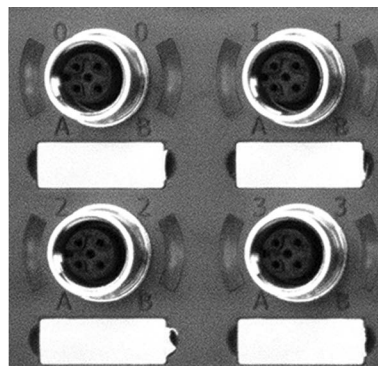

IO-Link, Class A Master
2 x Digital Inputs or
2 x Digital Outputs

IO-Link, Class A Master or
2 x Digital Inputs or
2 x Digital Outputs



For inventory, lead times, and kit lookup, visit www.pdnplu.com

D195

Parker Hannifin Corporation
Pneumatic Division
Richland, Michigan
www.parker.com/pneumatics

D

Subbase & Manual Valves

H Series Micro

Modulflex Series

H Series ISO

Network Connectivity

DX ISOMAX Series

Valvair II Series

Features

PCH Network Portal

Module Variants

Module

B

What is a Module Variant?

- The PCH Network Portal has 3 available Module Positions. Each module position can be populated with three different Module Variants
- Each Module Position can accept all module variants

Port Behavior

- Each port is capable of the following behavior listed below
- Through software, the user can click and change how the port behaves on the fly
- The B Module Variant gives the user access to IO-Link Class B Master ports



Possible Port Behavior

- IO-Link, Class B Master or
1 x Digital Input or
1 x Digital Output*
- IO-Link, Class B Master or
1 x Digital Input or
1 x Digital Output*

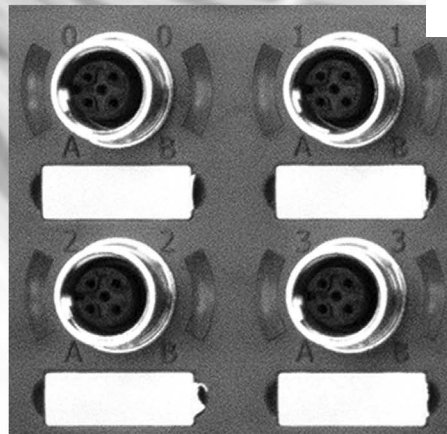

- IO-Link, Class B Master or
1 x Digital Input or
1 x Digital Output*
- IO-Link, Class B Master or
1 x Digital Input or
1 x Digital Output*

*Digital Output draws current from logic power

Port Behavior

- Each port's behavior can differ from one another
- For example, the user can select the behavior listed below through software (shown below)

- IO-Link, Class B Master or
1 x Digital Input
- IO-Link, Class B Master or
1 x Digital Input or
1 x Digital Output

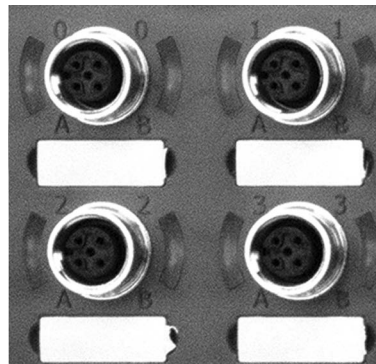

- IO-Link, Class B Master**
- IO-Link, Class B Master or
1 x Digital Input or
1 x Digital Output
- IO-Link, Class B Master or
1 x Digital Input or
1 x Digital Output

D	Subbase & Manual Valves
H Series Micro	H Series Micro
Modulflex Series	Modulflex Series
H Series ISO	H Series ISO
Network Connectivity	Network Connectivity
DX ISOMAX Series	DX ISOMAX Series
Valvair II Series	Valvair II Series



For inventory, lead times, and kit lookup, visit www.pdnplu.com

Features

PCH Network Portal

Module Variants

Module



What is a Module Variant?

- The PCH Network Portal has 3 available Module Positions. Each module position can be populated with three different Module Variants
- Each Module Position can accept all module variants

Port Behavior

- Each port is capable of the following behavior listed below
- Through software, the user can click and change how the port behaves on the fly
- The C Module Variant gives the user access to IO-Link Class B Master ports and fixed high current outputs

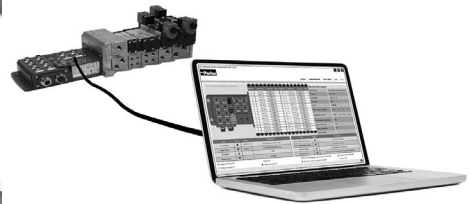

Possible Port Behavior

2 x Digital Outputs, 500 mA each, Fixed ¥

IO-Link, Class B Master or
1 x Digital Input or
1 x Digital Output*

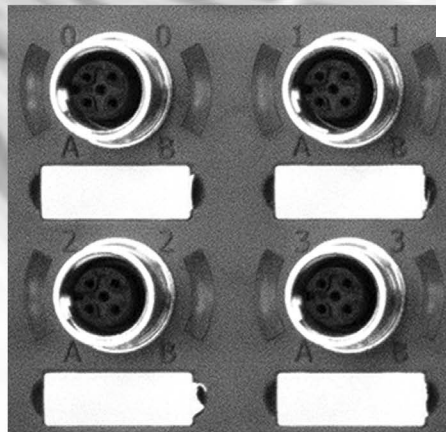

2 x Digital Outputs, 500 mA each, Fixed ¥

IO-Link, Class B Master or
1 x Digital Input or
1 x Digital Output*

¥ Digital Outputs draw current from auxiliary power
* Digital Output draws current from logic power

Port Behavior

- Each port's behavior can differ from one another
- For example, the user can select the behavior listed below through software (shown below)

2 x Digital Outputs, 500 mA each, Fixed

IO-Link, Class B Master or
1 x Digital Input or
1 x Digital Output

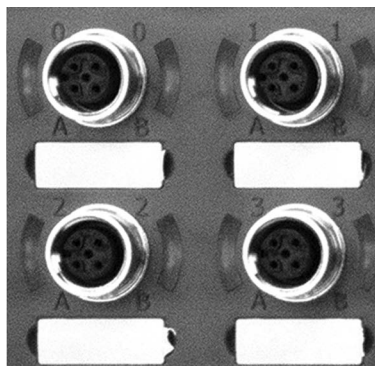

2 x Digital Outputs, 500 mA each, Fixed

IO-Link, Class B Master
1 x Digital Input or
1 x Digital Output



For inventory, lead times, and kit lookup, visit www.pdnplu.com

I/O Module Combinations

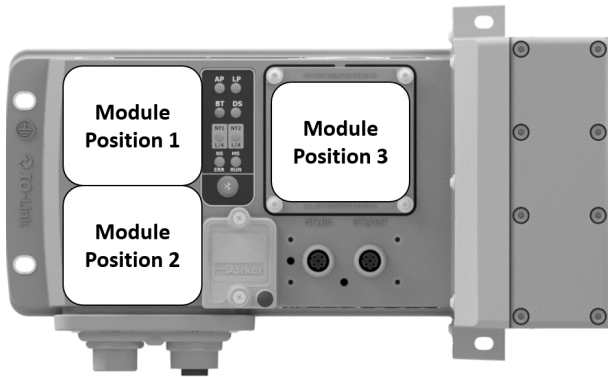

- The PCH Network Portal gives true port flexibility
- The PCH Network Portal can be ordered with 3 available module variants
- Each module variant has 4, M12 Ports
- Each module variants can be chosen in any module position
- Each port is individually software configurable
- A blanking plate is available for Module Position 3
- **Important:** Once Module Variants are selected on the PCH Network Portal, they cannot be changed in the field

Before it comes through your door
Select which Module Variant you want in each Module Position



After it comes through your door
Truly Configurable I/O - Select port behavior from listed options

D

Subbase & Manual Valves

H Series Micro

Modulflex Series

H Series ISO

Network Connectivity

DX ISOMAX Series

Valvair II Series

Module Variants

Module A		<ul style="list-style-type: none"> • IO-Link, Class A Master OR • 2 Inputs, PNP/NPN OR • 2 Outputs, 250 mA ea 		<ul style="list-style-type: none"> • IO-Link, Class A Master OR • 2 Inputs, PNP/NPN OR • 2 Outputs, 250 mA ea
		<ul style="list-style-type: none"> • IO-Link, Class A Master OR • 2 Inputs, PNP/NPN OR • 2 Outputs, 250 mA ea 		<ul style="list-style-type: none"> • IO-Link, Class A Master OR • 2 Inputs, PNP/NPN OR • 2 Outputs, 250 mA ea
Module B		<ul style="list-style-type: none"> • IO-Link, Class B Master OR • 1 Input, PNP/NPN OR • 1 Output, 250 mA ea 		<ul style="list-style-type: none"> • IO-Link, Class B Master OR • 1 Input, PNP/NPN OR • 1 Output, 250 mA ea
		<ul style="list-style-type: none"> • IO-Link, Class B Master OR • 1 Input, PNP/NPN OR • 1 Output, 250 mA ea 		<ul style="list-style-type: none"> • IO-Link, Class B Master OR • 1 Input, PNP/NPN OR • 1 Output, 250 mA ea
Module C		<ul style="list-style-type: none"> • 2 Outputs, 500 mA ea 		<ul style="list-style-type: none"> • 2 Outputs, 500 mA ea
		<ul style="list-style-type: none"> • IO-Link, Class B Master OR • 1 Input, PNP/NPN OR • 1 Output, 250 mA ea 		<ul style="list-style-type: none"> • IO-Link, Class B Master OR • 1 Input, PNP/NPN OR • 1 Output, 250 mA ea
Module N	Blank Cover, No Ports, Only available in Position 3			



For inventory, lead times, and kit lookup, visit www.pdnplu.com

I/O Module Combinations

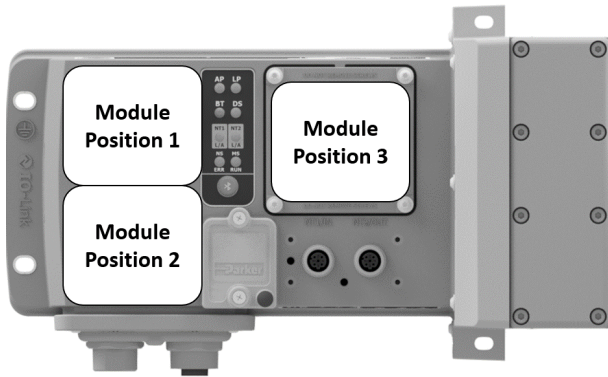

- Below are 16 standard module combinations
- For simplicity, similar combinations of modules are consolidated into one combination



Example Model Structure



Below are the standard module configurations

Refer to page 183 for full product Module Structure.

Order Code	Module Position 1	Module Position 2	Module Position 3
AAA	A	A	A
AAB	A	A	B
AAC	A	A	C
AAN	A	A	N
ABB	A	B	B
ABC	A	B	C
ABN	A	B	N
ACC	A	C	C
ACN	A	C	N
BBB	B	B	B
BBC	B	B	C
BBN	B	B	N
BCC	B	C	C
BCN	B	C	N
CCC	C	C	C
CCN	C	C	N

For any module configurations not listed, consult factory.

D
Subbase & Manual Valves
H Series Micro
Moduflex Series
H Series ISO
Network Connectivity
DX ISOMAX Series
Valvair II Series



For inventory, lead times, and kit lookup, visit www.pdnplu.com

Power Options

- The PCH Network Portal has 4 available power connectors
- There are two power schemes that can be achieved detailed below
- Any I/O ports using AUX power and any attached H ISO Universal manifold valves draw power from the AUX power pins of the power connector

Consumption @ 24 VDC

AUX power max consumption 12A
 Logic power max consumption 8A

Total possible passthrough for AUX line and Logic 20A

Any power left over can be passed on to other devices on the network



Power Connector *	
4-pin power in/out with 1 safe power capable zone	P4
5-pin power in/out with 1 safe power capable zone	P5
4-pin power in/in with 2 safe power zones	S4
5-pin power in/in with 2 safe power zones	S5

D
 Subbase & Manual Valves
 H Series Micro
 Modulflex Series
 H Series ISO
 Network Connectivity
 DX ISOMAX Series
 Valvair II Series

Power Scheme 1

- All 32 addresses are controlled in the same power zone
- Safety zoning is possible for valve solenoids and, with the H ISO Universal valves, pneumatic pressure
- Power zone is safe power capable
- Available in 4 or 5-pin 7/8" power connectors

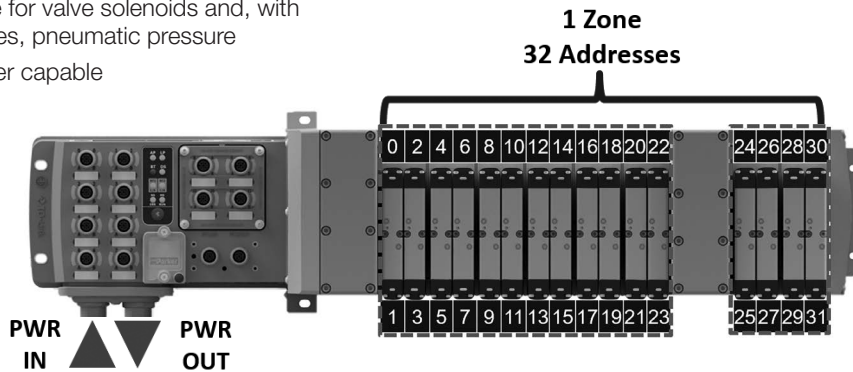

Power Scheme 2

- The power connector separates the valve power
- Each zone has an isolated safe ground pin so each can be powered by a SAFE 24 VDC auxiliary source in PP or PM mode
- Available in 4 or 5 pin 7/8" power connectors

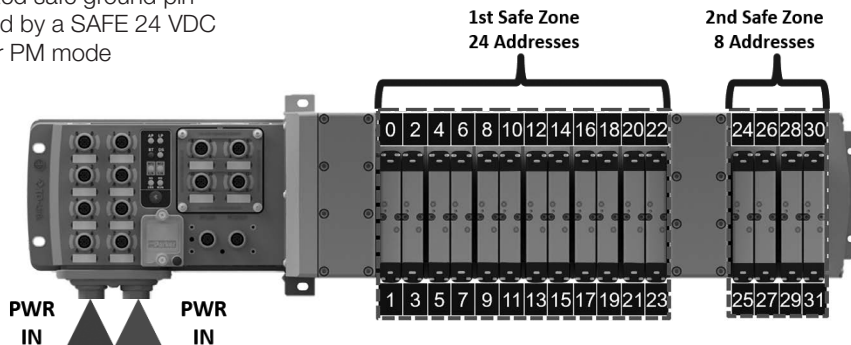

For inventory, lead times, and kit lookup, visit www.pdnplu.com

D200

Parker Hannifin Corporation
 Pneumatic Division
 Richland, Michigan
www.parker.com/pneumatics

Common Part Numbers

Popular Module Combinations

- Listed below are popular module configurations
- For full model number structure, please refer to next page

EtherNet/IP™

Popular Part Number Configurations						
Pilot Type	Thread Type	Module Position			Power Connector	End Plate Part Number
		1	2	3		
Internal	NPT	A	A	A	4-pin power IN/OUT with 1 safe power capable zone	PSHU20P300PEAAA0-P4
Internal	NPT	A	A	B	4-pin power IN/OUT with 1 safe power capable zone	PSHU20P300PEAAB0-P4
Internal	NPT	A	B	C	4-pin power IN/OUT with 1 safe power capable zone	PSHU20P300PEABC0-P4
Internal	NPT	A	A	N	4-pin power IN/OUT with 1 safe power capable zone	PSHU20P300PEAAN0-P4
Internal	NPT	A	A	A	5-pin power IN/OUT with 1 safe power capable zone	PSHU20P300PEAAA0-P5
Internal	NPT	A	A	B	5-pin power IN/OUT with 1 safe power capable zone	PSHU20P300PEAAB0-P5
Internal	NPT	A	A	C	5-pin power IN/OUT with 1 safe power capable zone	PSHU20P300PEAAC0-P5
Internal	NPT	A	A	N	5-pin power IN/OUT with 1 safe power capable zone	PSHU20P300PEAAN0-P5
Internal	NPT	A	A	A	4-pin power IN/IN with 2 safe power zones	PSHU20P300PEAAA0-S4
Internal	NPT	A	A	N	5-pin power IN/IN with 2 safe power zones	PSHU20P300PEAAN0-S5



Popular Part Number Configurations						
Pilot Type	Thread Type	Module Position			Power Connector	End Plate Part Number
		1	2	3		
Internal	NPT	A	A	A	5-pin power IN/OUT with 1 safe power capable zone	PSHU20P300PNAAA0-P5
Internal	NPT	A	A	B	5-pin power IN/OUT with 1 safe power capable zone	PSHU20P300PNAB0-P5
Internal	NPT	A	B	C	5-pin power IN/OUT with 1 safe power capable zone	PSHU20P300PNABC0-P5
Internal	NPT	A	A	N	5-pin power IN/OUT with 1 safe power capable zone	PSHU20P300PNAAN0-P5
Internal	NPT	A	A	A	5-pin power IN/OUT with 1 safe power capable zone	PSHU20P300PNAAA0-P5
Internal	NPT	A	A	B	5-pin power IN/IN with 2 safe power zones	PSHU20P300PNAB0-S5
Internal	NPT	A	A	C	5-pin power IN/IN with 2 safe power zones	PSHU20P300PNAAC0-S5
Internal	NPT	A	A	N	5-pin power IN/IN with 2 safe power zones	PSHU20P300PNAAN0-S5
Internal	NPT	A	A	A	5-pin power IN/IN with 2 safe power zones	PSHU20P300PNAAA0-S5
Internal	NPT	A	A	N	5-pin power IN/IN with 2 safe power zones	PSHU20P300PNAAN0-S5

EtherCAT®

Popular Part Number Configurations						
Pilot Type	Thread Type	Module Position			Power Connector	End Plate Part Number
		1	2	3		
Internal	NPT	A	A	A	4-pin power IN/OUT with 1 safe power capable zone	PSHU20P300PTAAA0-P4
Internal	NPT	A	A	B	4-pin power IN/OUT with 1 safe power capable zone	PSHU20P300PTAAB0-P4
Internal	NPT	A	B	C	4-pin power IN/OUT with 1 safe power capable zone	PSHU20P300PTABC0-P4
Internal	NPT	A	A	N	4-pin power IN/OUT with 1 safe power capable zone	PSHU20P300PTAAN0-P4
Internal	NPT	A	A	A	5-pin power IN/OUT with 1 safe power capable zone	PSHU20P300PTAAA0-P5
Internal	NPT	A	A	B	5-pin power IN/OUT with 1 safe power capable zone	PSHU20P300PTAAB0-P5
Internal	NPT	A	A	C	5-pin power IN/OUT with 1 safe power capable zone	PSHU20P300PTAAC0-P5
Internal	NPT	A	A	N	5-pin power IN/OUT with 1 safe power capable zone	PSHU20P300PTAAN0-P5
Internal	NPT	A	A	A	4-pin power IN/IN with 2 safe power zones	PSHU20P300PTAAA0-S4
Internal	NPT	A	A	N	5-pin power IN/IN with 2 safe power zones	PSHU20P300PTAAN0-S5



For inventory, lead times, and kit lookup, visit www.pdnplu.com

D201

Parker Hannifin Corporation
Pneumatic Division
Richland, Michigan
www.parker.com/pneumatics

D

Subbase & Manual Valves

H Series Micro

Moduflex Series

H Series ISO

Network Connectivity

DX ISOMAX Series

Valvair II Series

Ordering Information

End Plate Kit – Universal Plug-in

The PCH Network Portal is ordered as an endplate kit. This includes the PCH Network Portal, left hand air supply module, and right hand end plate.

For fully assembled manifold Add-A-Fold part number, reference page D88



PSHU20 P3 0 0 P E AAA 0 - P4

Valve Type	
Plug-in (Internal pilot)	PSHU20
Plug-in (External pilot)	PSHU2X

Thread Type	
NPT	0
BSPP "G"	1

Network Connections	
EtherNet/IP™	E
EtherCAT	T
PROFINET	N
Modbus TCP	M

Power Connector	
4-pin power IN/OUT with 1 safe power capable zone	P4
5-pin power IN/OUT with 1 safe power capable zone	P5
4-pin power IN/IN with 2 safe power zones	S4
5-pin power IN/IN with 2 safe power zones	S5

Right Hand End Plate Type / Thread Size	
Low profile (no ports)	0
1/2 Exhaust and inlet port	1
3/4 Exhaust and inlet port	2
H3 Transition plate and end plate (electrical pass through for plug-in valves only)	3
H3 Transition plate and end plate (expansion to 25th address for plug-in valves only)	4

Module Combinations		
Module Position 1	Module Position 2	Module Position 3
A	A	A
A	A	B
A	A	C
A	A	N
A	B	B
A	B	C
A	B	N
A	C	C
A	C	N
B	B	B
B	B	C
B	B	N
B	C	C
B	C	N
C	C	C
C	C	N

For any module configurations not listed, consult factory.

D	Subbase & Manual Valves
	H Series Micro
	Modulflex Series
	H Series ISO
	Network Connectivity
	DX ISOMAX Series
	Valvair II Series

Most popular.



For inventory, lead times, and kit lookup, visit www.pdnplu.com

Mechanical Data

Housing Material	Housing /Enclosure: PBT with 33% GF and UL94-V0 Base Cover (plate): Aluminum 380
Enclosure rating	IP 65 (only when plugged-in and threaded-in)
Power Connectors	7/8" 4 or 5 pin male and female pin connector
Input ports/ Output ports	M12, A-coded (12 x female)
Dimensions (L x B x H in mm)	226.6mm x 130.7mm x 55mm
Mounting type	Screw Mount
Ground strap attachment	M5
Weight	Approx. 1.3 kg

Operating Conditions

Operating Temperature	0°C to 50°C
Storage Temperature	-25°C to 70°C
CE as per	IEC 61000-6-2 (Industrial Immunity)
	IEC 61000-6-4 (Industrial Emission)
Shock/Vibrations	IEC 60068-2-27:2008
	IEC 60068-2-6:2007
Electrostatic Discharge	IEC 61000-4-2
Electrical Fast Transient/ Burst	IEC 61000-4-4
Surge Immunity	IEC 61000-4-5

Electrical Data

Supply Voltage	24VDC (-15% to +20%)
Logic current at 24 V (V1)	Max Current 8A – Actual usage depends on configuration
Auxiliary current at 24 V (V2)	Max Current 12A – Actual usage depends on configuration

Valve Configuration

Compatible Valves	H Universal ISO Valves
Available addresses	24 addresses, 32 addresses with H Universal Extension Slice



For inventory, lead times, and kit lookup, visit www.pdnplu.com

D203

Parker Hannifin Corporation
Pneumatic Division
Richland, Michigan
www.parker.com/pneumatics

D

Subbase & Manual Valves

H Series Micro

Moduflex Series

H Series ISO





Network Connectivity

DX ISOMAX Series

Valvair II Series









I/O Port Pin Outs

- The PCH Network Portal uses threaded M12 Ports for I/O Connections
- All configurable ports are configurable through software at any time

Module Variant	Connector	Pin No.	Function
A *Applies to ports 1-4 of this module		1	+24V, 500mA VLOG (V1)
		2	Input (PNP or NPN) / Output +24V, 250 mA (V1)
		3	GND (V1)
		4	IO-Link/Input (PNP or NPN) / Output +24V, 250mA (V1)
		5	Not Connected
B *Applies to ports 1-4 of this module		1	+24V, 250mA VLOG (V1)
		2	+24V, 1.2A VAUX (V2)
		3	GND (V1)
		4	IO-Link/Input (PNP or NPN) / Output +24V, 250mA (V1)
		5	GND (V2)
C *Applies to ports 1-2 of this module		1	Not Connected
		2	Output +24VAUX (V2), 500mA
		3	GND (V2)
		4	Output +24VAUX (V2), 500mA
		5	Not Connected
D *Applies to ports 3-4 of this module		1	+24V, 250mA VLOG (V1)
		2	+24V, 1.2A VAUX (V2)
		3	GND (V1)
		4	IO-Link/Input (PNP or NPN) / Output +24V, 250mA (V1)
		5	GND (V2)

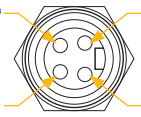
Power Conector Pin Outs

- The PCH Network Portal uses 7/8" ports for its left IN and right OUT or IN power connectors.
- Any power configuration below can be ordered
- For AIDA power connector, consult factory

	Left Power Connector: Power IN				Right Power Connector: Power OUT				
	Connector	Pin No.	Function	Description	Connector	Pin No.	Function	Description	
P4 		1	+24 V	V2 (VAUX), 12A			1	+24 V	V2 (VAUX), 3.8A
		2	+24 V	V1 (VLOG), 8A			2	+24 V	V1 (VLOG), 1.28A
		3	0 V	GND V1 (VLOG)			3	0 V	GND V1 (VLOG)
		4	0 V	GND V2 (VAUX)			4	0 V	GND V2 (VAUX)
		5	0 V	GND V2 (VAUX)			5	0 V	GND V2 (AUX)
P5 		1	0 V	GND V2 (VAUX)			1	0 V	GND V2 (AUX)
		2	0 V	GND V1 (VLOG)			2	0 V	GND V1 (VLOG)
		3	Protective Earth	Protective Earth			3	Protective Earth	Protective Earth
		4	+24 V	V1 (VLOG), 8A			4	+24 V	V1 (VLOG)
		5	+24 V	V2 (VAUX), 12A			5	+24 V	V2 (VAUX)
S4 		1	+24 V	V2 (VAUX), 12A			1	+24 V	V2 (VAUX), 3.8A
		2	+24 V	V1 (VLOG), 8A			2	+24 V	V1 (VAUX), 1.28A
		3	0 V	GND V1 (VLOG)			3	0 V	Safe GND 1-3*
		4	0 V	GND V2 (VAUX)			4	0 V	Safe GND 4*
		5	0 V	GND V2 (VAUX)			5	0 V	Safe GND 4*
S5 		1	0 V	GND V2 (VAUX)			1	+24 V	V2 (VAUX), 3.8A
		2	0 V	GND V1 (VLOG)			2	+24 V	V1 (VAUX), 1.28A
		3	Protective Earth	Protective Earth			3	Protective Earth	Protective Earth
		4	+24 V	V1 (VLOG), 8A			4	0 V	Safe GND 1-3*
		5	+24 V	V2 (VAUX), 12A			5	0 V	Safe GND 4*

*"Safe GND 1-3" refers to solenoid addresses 0-23 and "Safe GND 4" refers to solenoid addresses 24-31



For inventory, lead times, and kit lookup, visit www.pdnplu.com

D204

Parker Hannifin Corporation
 Pneumatic Division
 Richland, Michigan
www.parker.com/pneumatics

Subbase & Manual Valves
 H Series Micro
 Modulflex Series
 H Series ISO
 Network Connectivity
 DX ISOMAX Series
 Valvair II Series

Solenoid Addressing

- The PCH Network Portal can use the following H ISO Universal Valves:
 - ISO 15407-2 – sizes 02 & 01
 - ISO 5599-2 – sizes 1, 2 & 3
- The PCH Network Portal can support up to 32 addresses as shown
- The data map and PCH Tool refers to each address with a Valve_X designator. Each Valve_X designator is as shown.
- Addresses 25-31 can be accessed using an Intermediate Air Supply with Electric Expansion
- Each address is one solenoid

Air Supply

HB Single Address Manifold

H1 Single Address Manifold

H1 Double Address Manifold

HA Double Address Manifold

H2 Single Address Manifold

H2 Double Address Manifold

Air Supply Zero Address Manifold

H1 Single Address Manifold

H1 Double Address Manifold

HB Double Address Manifold

HA Single Address Manifold

H2 Single Address Manifold

H2 Double Address Manifold

Low Profile End Plate (No Ports)

EV4 Address 4

EV6 Address 6

EV8 Address 8

EV11 Address 11

EV14 Address 14

EV16 Address 16

EV18 Address 18

EV23 Address 23

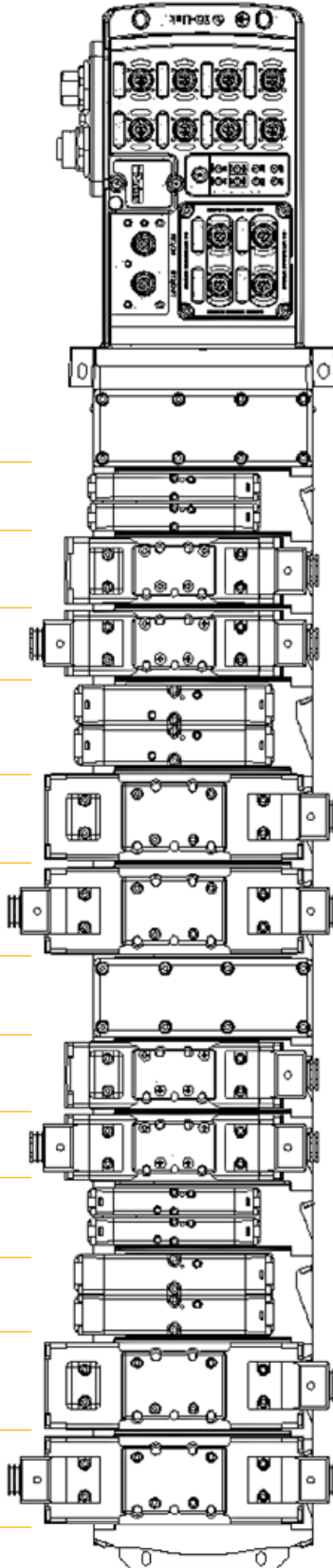

EV0 Address 0

EV1 Address 1

EV2 Address 2

EV3 Address 3

EV5 Address 5

EV7 Address 7

EV9 Address 9

EV10 Address 10

EV12 Address 12

EV13 Address 13

EV15 Address 15

EV17 Address 17

EV19 Address 19

EV20 Address 20

EV21 Address 21

EV22 Address 22

D

Subbase & Manual Valves

H Series Micro

Moduflex Series

H Series ISO

Network Connectivity

DX ISOMAX Series

Valvair II Series



For inventory, lead times, and kit lookup, visit www.pdnplu.com

D205

Parker Hannifin Corporation
 Pneumatic Division
 Richland, Michigan
www.parker.com/pneumatics

PCH Network Portal with H Series ISO Valves

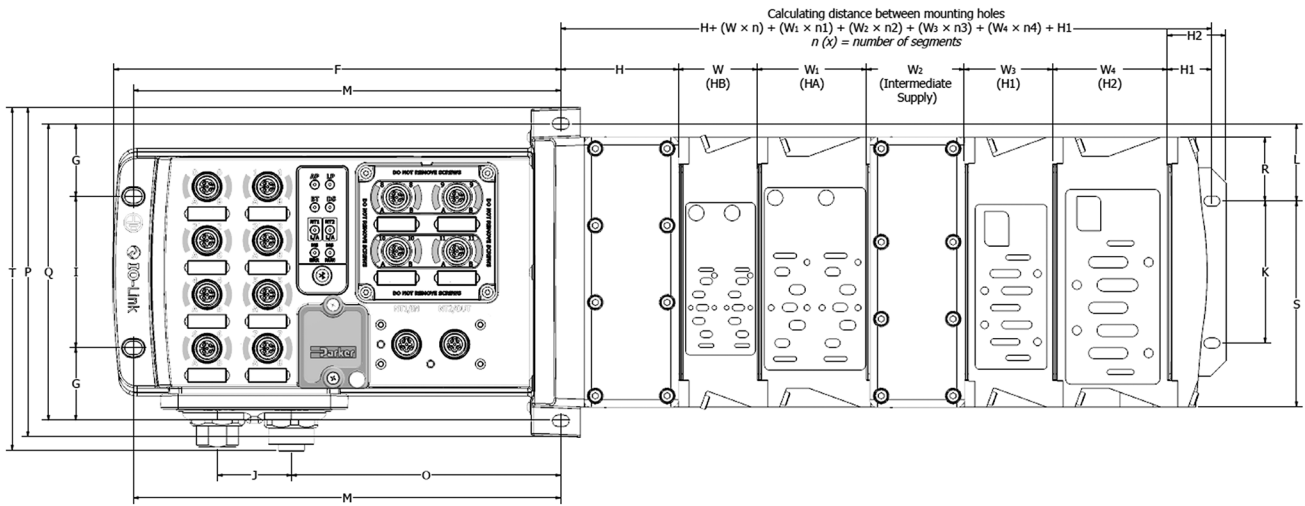

n (x) = number of segments

A	B	C	D	E	F	G	H	H ₁	H ₂	J	K	L
4.42 (112.3)	2.64 (67.1)	2.46 (62.5)	1.17 (29.7)	.55 (14)	9.32 (236.7)	1.51 (38.4)	2.36 (59.9)	.9 (22.9)	1.22 (31)	1.55 (39.4)	2.95 (74.9)	1.6 (40.6)
M	O	P	Q	R	S	T	W	W ₁	W ₂	W ₃	W ₄	
8.91 (226.3)	5.61 (142.5)	6.86 (174.2)	6.18 (157)	1.33 (33.8)	4.28 (108.7)	7.14 (181.4)	1.63 (41.4)	2.28 (57.9)	2.03 (51.6)	1.82 (46.2)	2.39 (60.7)	

Inches (mm)

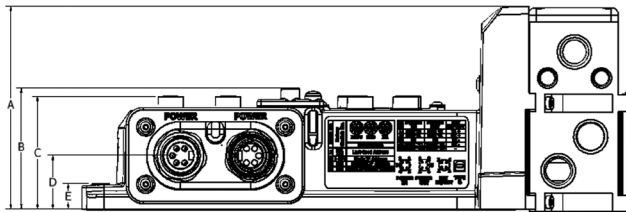

D
Subbase & Manual Valves
H Series Micro
Modulflex Series
H Series ISO
Network Connectivity
DX ISOMAX Series
Valvair II Series



For inventory, lead times, and kit lookup, visit www.pdnplu.com

D206

Parker Hannifin Corporation
Pneumatic Division
Richland, Michigan
www.parker.com/pneumatics

Product Support

- The PCH Network Portal Product Landing page can be accessed at the following:



www.parker.com/pdn/PCHPortal

- The PCH Network Portal support material can be accessed at the following:



www.parker.com/pdn/networkconnectivity

- The PCH Connect - Bluetooth App



User Manuals

- The PCH Network Portal User Manuals can be accessed at the following website. Click on QR code for hyperlink.

EtherNet/IP™ EtherNet/IP™ User Manual



Profinet User Manual



EtherCAT® EtherCAT User Manual



Modbus User Manual



For more information on IO-link

www.io-link.com



For inventory, lead times, and kit lookup, visit www.pdnplu.com

D207

Parker Hannifin Corporation
Pneumatic Division
Richland, Michigan
www.parker.com/pneumatics

D

Subbase & Manual Valves

H Series Micro

Moduflex Series

H Series ISO

Network Connectivity

DX ISOMAX Series

Valvair II Series

Features

The Turck Network Portal

Turck Network Portal has four major components:

- **Valve Driver Module** provide control for either 16 or 32 solenoids on a manifold
- **I/O Modules** provide the field interface and system-interface circuitry
- **Communication Modules** provide the network-interface circuitry
- **Power Distribution Module** provide 5 additional power inputs to the Turck system

Turck Features

- Highly modular design (4pt – 16pt modularity)
- Broad application coverage
- Expandable 4 port Class A IO-Link master
- Channel-level diagnostics (LED and electronic)
- Channel-level alarm and annunciation (electronic)
- Channel-level open-wire detection with electronic feedback
- Channel-level short-circuit detection with electronic feedback
- Horizontal and vertical mounting without derating
- 5g vibration
- Electronic and mechanical keying
- Robust backplane design
- Quick-disconnects for I/O and network connectivity
- Built-in panel grounding
- Color-coded module labels
- UL, cCSAus, and CE certifications (as marked)
- Highly reliable structural integrity
- Optical isolation between field and system circuits

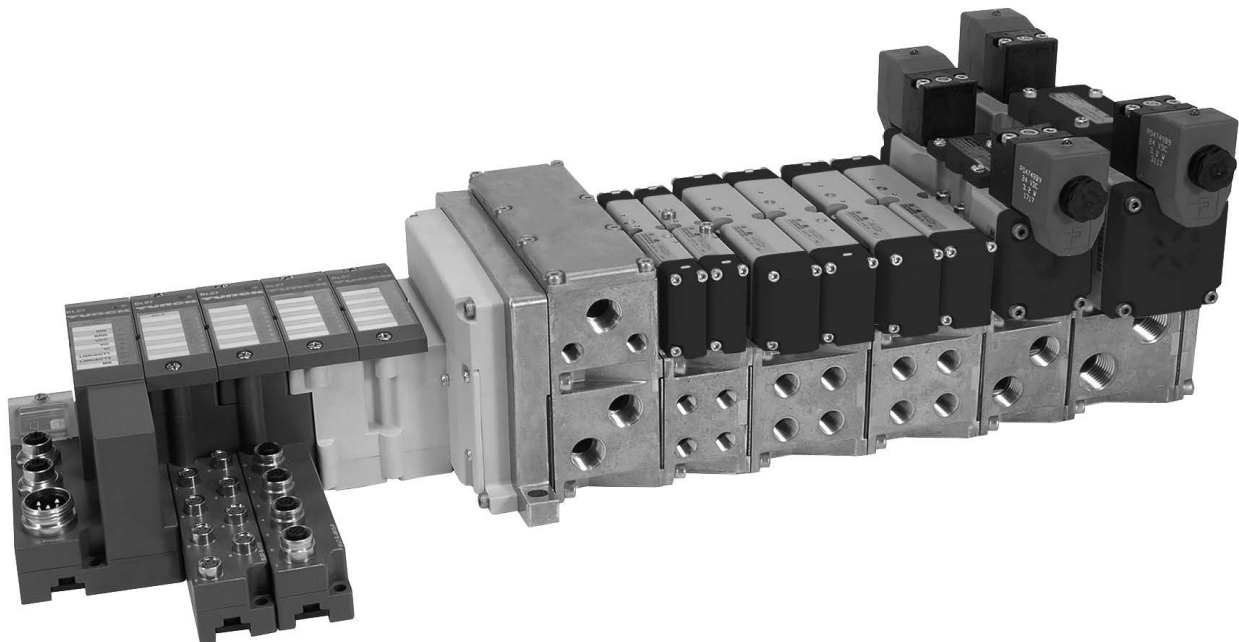

D

Subbase & Manual
ValvesH Series
MicroModulflex
SeriesH Series
ISONetwork
ConnectivityDX ISOMAX
SeriesValvair II
Series

For inventory, lead times, and kit lookup, visit www.pdnplu.com

D208

Parker Hannifin Corporation
Pneumatic Division
Richland, Michigan
www.parker.com/pneumatics

Turk Network Portal

- A complete network communication offering for all H Series ISO and H Series Micro valves
- CSA, cULus and CE certifications (as marked)

I/O Configuration

- Centralized Turk Network Portal
- Pneumatics and I/O are in close proximity with one another
- M23, 12-Pin or 19-Pin output extension to an additional H Series valve manifold
- I/O density per module = 4, 8 or 16

EtherNet/IP™

DeviceNet

PROFI®
 PROCESS FIELD BUS

PROFI®
 INDUSTRIAL NETWORK

Modbus/TCP™

CANopen

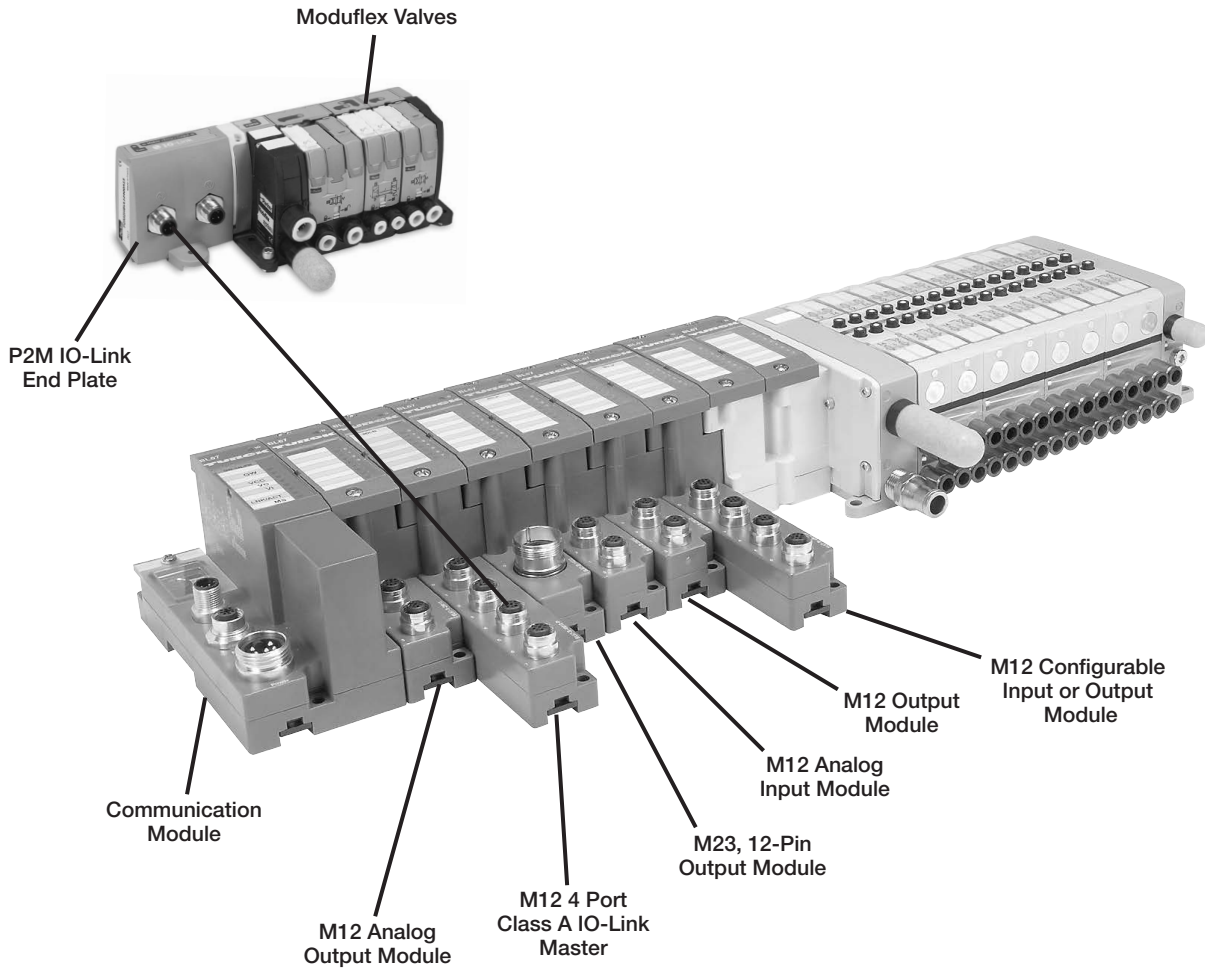

Configure / Program any module with RS232, or directly through Ethernet for any module with an Ethernet physical layer.



D

Subbase & Manual Valves

H Series Micro

Moduflex Series

H Series ISO

Network Connectivity

DX ISOMAX Series

Valvair II Series



For inventory, lead times, and kit lookup, visit www.pdnplu.com

D209

Parker Hannifin Corporation
 Pneumatic Division
 Richland, Michigan
www.parker.com/pneumatics

Turk Network Portal

- A complete network communication offering for all H Series ISO and H Series Micro valves.
- CSA, cCSAus and CE certifications (as marked).

I/O Configuration

- Complete control of all I/O and valves with stand alone control
- Additional I/O and valves connected over DeviceNet with BL Remote Subnet
- BL Remote connection to P2M and Turk DeviceNet equipped communication modules
- I/O density per module = 4, 8 or 16

EtherNet/IP™

DeviceNet™

PROFIBUS™

PROFINET™

Modbus/TCP™

CANopen

D
Subbase & Manual Valves
H Series Micro
Modulflex Series
H Series ISO
Network Connectivity
DX ISOMAX Series
Valvair II Series

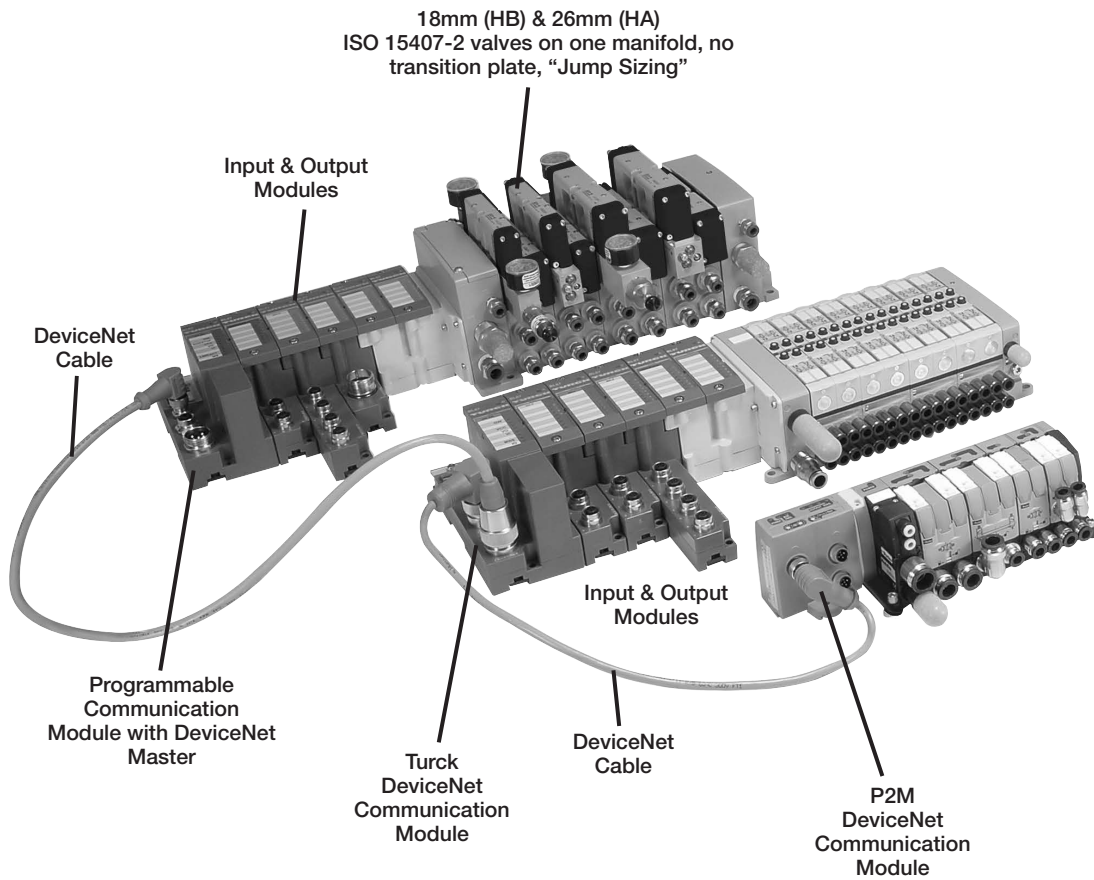

For inventory, lead times, and kit lookup, visit www.pdnplu.com

D210

Parker Hannifin Corporation
 Pneumatic Division
 Richland, Michigan
www.parker.com/pneumatics

Communications Module

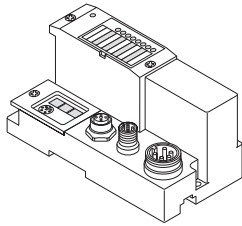

BL67 communication modules are the heart of a BL67 station. They are designed to connect the modular nodes to the higher level network (PROFIBUS-DP, DeviceNet, CANopen, Ethernet).

All BL67 electronic modules communicate over the internal module bus with the communication modules. The communication module structures the data and sends them clustered via network nodes to the higher control system.

This way all I/O modules can be configured independently of the system.

Electronic Module

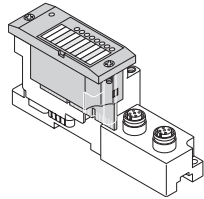

BL67 electronic modules are inserted into the passive base modules from above and then simply affixed with two screws. Maintenance is extremely simplified due to the separation of connection level and module electronics.

Moreover, flexibility is enhanced because the base modules provide different types of connectors. Voltage supply for the electronic modules is either provided via the communication modules or a Power Extender module. Power Extender modules can be used to create galvanically isolated potential groups.

Base Module

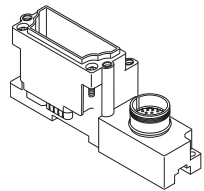

BL67 base modules are aligned one by one to the right of the communication module and are tightened each with two screws, either with the communication modules or with the previous module. A DIN rail is not required. This way a compact and stable unit is created which can be mounted directly on the machine.

The base modules serve for connection of the field devices and are available with different connection types (M8, M12, M23 and 7/8).

A BL67 system can be extended to a total length of 1 m, comprising of a communication module for PROFIBUS-DP, DeviceNet / CANopen or Ethernet and a maximum of 32 modules.

System supply: The power supply for the BL67 system is either derived separately for Profibus-DP and Ethernet communication modules or directly from the DeviceNet / CANopen cable for the DeviceNet / CANopen communication module.

Power Extender modules can be inserted anywhere in the BL67 station. They provide isolated field voltage for the I/O modules mounted to their right.

Thus Power Extender modules can also be used to create different potential groups.

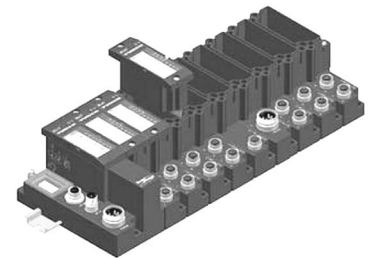

Maximum System Extension

Module type		PROFIBUS		DeviceNet		CANopen		ModbusTCP		EtherNet/IP		PROFIBUS NET	
		chan.	mod.	chan.	mod.	chan.	mod.	chan.	mod.	chan.	mod.	chan.	mod.
Digital inputs	4 DI	128	32	128	32	128	32	128	32	128	32	128	32
	8 DI	256	32	256	32	256	32	256	32	256	32	256	32
Digital outputs	4 DO	128	32	128	32	128	32	128	32	128	32	128	32
	8 DO	256	32	256	32	256	32	256	32	256	32	256	32
	16 DO	512	32	512	32	512	32	512	32	512	32	512	32
Analog inputs	2AI	64	32	64	32	64	32	64	32	64	32	64	32
	4AI	112	28	124	31	124	31	128	32	128	32	128	32
	2 AI-PT	56	28	64	32	64	32	64	32	64	32	64	32
	2 AI-TC	64	32	64	32	64	32	64	32	64	32	64	32
Analog outputs	2 AO-I	38	19	64	32	64	32	64	32	64	32	64	32
	2 AO-V	38	19	50	25	50	25	50	25	50	25	50	25



For inventory, lead times, and kit lookup, visit www.pdnplu.com

D211

Parker Hannifin Corporation
 Pneumatic Division
 Richland, Michigan
www.parker.com/pneumatics

D

Subbase & Manual Valves

H Series Micro

Modulflex Series

H Series ISO

Network Connectivity

DX ISOMAX Series

Valvair II Series

BL67-GW-DN

DeviceNet Communication
 Module with Power Over
 the Network

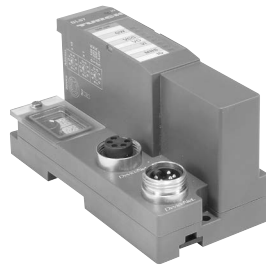

7/8 Mini bus in wiring,
 view into male connector

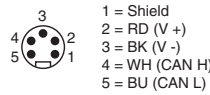

7/8 Mini bus out wiring,
 view into female connector

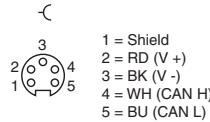

Turck Network Portal with up to 256 inputs, outputs, and 32 solenoids per H Series Micro or H Series ISO manifold. Digital inputs / outputs, analog inputs / outputs, serial interface, and counter modules are available. DeviceNet communication speeds selectable between 120, 250, 500 kbps, and CANopen communication speeds are selectable between 10 kbps up to 1 Mbps. Addressing for either module can be selected via rotary switches or set through software.

With the Power over the Network feature, it is only necessary to connect one cable to the communication module. For networks requiring additional power, a Bus Power Tee can be installed to combine separate network and power feeds into the communication module. See the Cables and Cordsets section for additional information.

BL67-GW-DPV1

PROFIBUS Communication
 Module



M12 B-code bus out Wiring,
 view into female connector

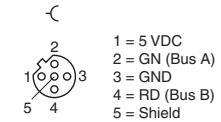

M12 B-code bus In Wiring,
 view into male connector

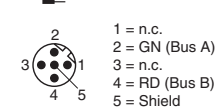

7/8 Mini Power in wiring,
 view into male connector

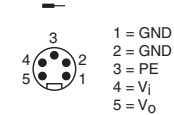

Turck Network Portal with up to 256 inputs, outputs, and 32 solenoids per H Series Micro or H Series ISO manifold. Digital inputs / outputs, analog inputs / outputs, serial interface, and counter modules are available. PROFIBUS communication speeds are selectable between 9.6 kbps up to 12 Mbps, and addressing can be selected via rotary switches or set through software.

BL67-GW-CO

CANopen Communication
 Module



M12 A-code bus out Wiring,
 view into female connector

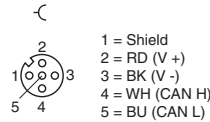

M12 A-code bus In Wiring,
 view into male connector

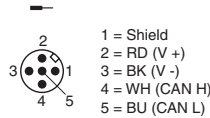

7/8 Mini Power in wiring,
 view into male connector

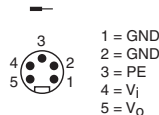

Turck Network Portal with up to 256 inputs, outputs, and 32 solenoids per H Series Micro or H Series ISO manifold. Digital inputs / outputs, analog inputs / outputs, serial interface, and counter modules are available. CANopen communication speeds are selectable between 10 kbps up to 1 Mbps, and addressing can be selected via rotary switches or set through software.

BL67-GW-EN

Modbus/TCP, EtherNet/IP™, and PROFINET

BL67-GW-EN-PN

PROFINET Communication Module



M12 D-code
 Ethernet in Wiring,
 view into female connector

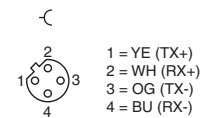

7/8 Mini Power in wiring,
 view into male connector

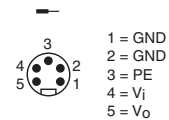

Turck Network Portal with up to 256 inputs, outputs, and 32 solenoids per H Series Micro or H Series ISO manifold. Digital inputs / outputs, analog inputs / outputs, serial interface, and counter modules are available. Communication speeds of 10/100 Mbps, and addressing can be selected via rotary switches, BOOTP, DHCP, or through software.

D
 Subbase & Manual
 Valves
 H Series
 Micro
 Modflex
 Series
 H Series
 ISO
 Network
 Connectivity
 DX ISOMAX
 Series
 Valvair II
 Series



For inventory, lead times, and kit lookup, visit www.pdnplu.com

BL67-GW-EN-DN

Modbus/TCP Communication Module with DeviceNet Subnet

BL67-GW-EN-IP-DN

EtherNet/IP™ Communication Module with DeviceNet Subnet



DeviceNet OUT

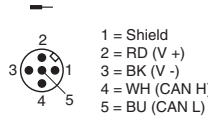

M12 D-code Ethernet in Wiring, view into female connector

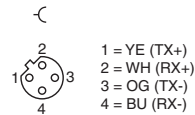

7/8 Mini Power in wiring, view into male connector

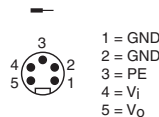

With BL Remote DeviceNet subnet functionality, each communication module has its own DeviceNet master which provides a connection for 63 DeviceNet nodes with additional inputs, outputs, and solenoid control. BL Remote DeviceNet subnet is independent of the main network, and is not visible to the master PLC.

BL67-PG-EN-DN

Modbus/TCP Programmable Communication Module with DeviceNet Subnet

BL67-PG-EN-IP-DN

EtherNet/IP™ Programmable Communication Module with DeviceNet Subnet



DeviceNet OUT

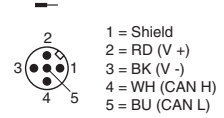

M12 D-code Ethernet in Wiring, view into female connector

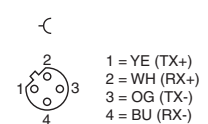

7/8 Mini Power in wiring, view into male connector

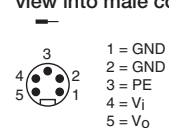

Communication modules are equipped with a built in standalone controller which is programmed according to IEC61131-3 with CoDeSys. Each module has 512KB Program memory with 32 bit RISC processor, and can run 1000 instructions in less than 1 ms. These network equipped modules are optimized to interface with PLC's with network capability or act as standalone controllers that need to interface with other network equipped devices.

With BL Remote DeviceNet subnet functionality, each communication module has its own DeviceNet master which provides a connection for 63 DeviceNet nodes with additional inputs, outputs, and solenoid control. BL Remote DeviceNet subnet is independent of the main network, and is not visible to the master PLC.

BL67-PG-DP

PROFIBUS Programmable Communication Module

BL67-PG-EN

Modbus/TCP Programmable Communication Module

BL67-PG-EN-IP

EtherNet/IP™ Programmable Communication Module



Profibus Wiring

M12 B-code bus out Wiring, view into female connector

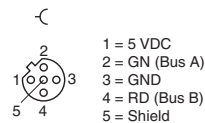

M12 B-code bus in Wiring, view into female connector

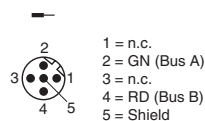

Ethernet Wiring

M12 D-code Ethernet in Wiring, view into female connector

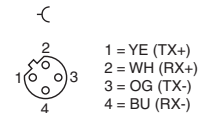

7/8 Mini Power in wiring, view into male connector Common to modules

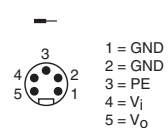

Communication modules are equipped with a built in standalone controller which is programmed according to IEC61131-3 with CoDeSys. Each module has 512KB Program memory with 32 bit RISC processor, and can run 1000 instructions in less than 1 ms. These network equipped modules are optimized to interface with PLC's with network capability or act as standalone controllers that need to interface with other network equipped devices.



For inventory, lead times, and kit lookup, visit www.pdnplu.com

D213

Parker Hannifin Corporation
 Pneumatic Division
 Richland, Michigan
www.parker.com/pneumatics

D

Subbase & Manual Valves

H Series Micro

Modulflex Series

H Series ISO

Network Connectivity

DX ISOMAX Series

Valvair II Series

D
 Subbase & Manual Valves
 H Series Micro
 Modulflex Series
 H Series ISO
 Network Connectivity
 DXISOMAX Series
 Valvair II Series

Base Modules													
	BL67-B-4M8	BL67-B-8M8	BL67-B-1M12	BL67-B-1M12-8	BL67-B-2M12	BL67-B-2M12-P	BL67-B-4M12	BL67-B-4M12-P	BL67-B-1M23	BL67-B-1M23-19	BL67-B-1RSM	BL67-B-1RSM-4	BL67-1RSM-VO
Power Extender Modules													
BL67-PF-24VDC											✓	✓	✓
Digital Input Modules													
BL67-4DI-P	✓				✓	✓	✓		✓				
BL67-8DI-P		✓					✓	✓	✓				
BL67-4DI-PD	✓				✓	✓	✓		✓				
BL67-8DI-PD		✓					✓	✓	✓				
BL67-4DI-N	✓				✓	✓	✓		✓				
BL67-8DI-N		✓					✓	✓	✓				
Digital Output Modules													
BL67-4DO-0.5A-P	✓				✓	✓	✓		✓				
BL67-4DO-2A-P	✓				✓	✓	✓		✓				
BL67-8DO-0.5A-P		✓					✓	✓	✓				
BL67-16DO-0.1A-P										✓			
BL67-4DO-2A-N	✓				✓	✓	✓		✓				
BL67-8DO-0.5A-N		✓					✓	✓	✓				
Relay Output Modules													
BL67-8DO-R-NO								✓					
Digital Input / Output Modules													
BL67-4DI4DO-PD		✓					✓	✓	✓				
Configurable Digital Input / Output Modules													
BL67-8XSG-PD		✓					✓	✓	✓				
Analog Input Modules													
BL67-2AI-I					✓								
BL67-2AI-V					✓								
BL67-4AI-V/I							✓						
BL67-2AI-PT					✓								
BL67-2AI-TC					✓								
Analog Output Modules													
BL67-2AO-I					✓								
BL67-2AO-V					✓								
Technology Modules													
BL67-1RS232			✓	✓					✓				
BL67-1RS485/422			✓	✓					✓				
BL67-1SSI				✓					✓				
BL67-1CNT/ENC				✓					✓				
BL67-1CVI			✓										
BL Ident® RFID Modules													
BL67-2RFID-A					✓								
BL67-2RFID-S					✓								



For inventory, lead times, and kit lookup, visit www.pdnplu.com

D214

Parker Hannifin Corporation
 Pneumatic Division
 Richland, Michigan
www.parker.com/pneumatics

System Supply via the Module Bus

The number of BL67 modules that can be powered by the communication module, depends on the nominal current draw of all the modules in the system. The total bus power current consumption of the installed BL67 modules may not exceed 1.5 A. The total field power current for inputs may not exceed 4 A, and the total field power for outputs may not exceed 8 A for DeviceNet and CANopen with power over the network, or 10A for all other communication modules.

When using the software PACTware, the menu item <Station - Verify> will automatically generate an error message if the system supply via the module bus is not reliably ensured.

Nominal Current Consumption

The following table shows the nominal current consumption of the various BL67 modules:

Modules	Bus power current (mA)	Field power for inputs ¹⁾ (mA)	Field power for outputs (mA)
PROFIBUS-DP communication module	0		150
DeviceNet communication module	0		150
CANopen communication module	0		150
Ethernet communication module	0		150
Valve driver with 16 outputs	30		< 109 mA (plus load current)
Valve driver with 32 outputs	60		< 218 mA (plus load current)
BL67-PF-24VDC	30		9
BL67-4DI-P	30	< 49 mA	
BL67-4DI-N	30	< 10 mA	
BL67-4DI-PD	30	< 109 mA	
BL67-8DI-P	30	< 49 mA	
BL67-8DI-N	30	< 10 mA	
BL67-8-DI-PD	30	< 109 mA	
BL67-4DO-0.5A-P	30		< 109 mA (plus load current)
BL67-4DO-2A-P	30		< 109 mA (plus load current)
BL67-4DO-2A-N	30		< 109 mA (plus load current)
BL67-8DO-0.5A-P	30		< 109 mA (plus load current)
BL67-8DO-0.5A-N	30		< 109 mA (plus load current)
BL67-16DO-0.1A-P	30		< 109 mA (plus load current)
BL67-4DI4DO-PD	30		< 109 mA (plus load current)
BL67-8XSG-PD	30		< 109 mA (plus load current)
BL67-8DO-R-NO	30		< 109 mA (plus load current)
BL67-2AI-V	35	< 22 mA	
BL67-2AI-I	35	< 22 mA	
BL67-4AI-I/V	35	< 22 mA	
BL67-2AI-TC	35	< 40 mA	
BL67-2AI-PT	45	< 58 mA	
BL67-2AO-I	40		< 62 mA
BL67-2AO-V	60		< 67 mA
BL67-1RS232	140	< 90 mA	
BL67-1RS485/422	60	< 42 mA	
BL67-1SSI	50	< 39 mA	
BL67-1CNT/ENC	30	< 109 mA	
BL67-1CVI	30	< 109 mA	

1) Is limited to 4A by means of the integrated short-circuit protection.



For inventory, lead times, and kit lookup, visit www.pdnplu.com

Part Numbers

Digital Input Modules

I/O modules	Voltage	Part number
8 PNP input module	7 to 30 VDC	BL67-8DI-P
8 PNP input module, with diagnostics	7 to 30 VDC	BL67-8DI-PD
8 NPN input module	24 VDC	BL67-8DI-N



Base module	Part number
8 x M8, 3 pole, female	BL67-B-8M8
4 x M12, 5 pole, female, A-code	BL67-B-4M12
4 x M12, 5 pole, female, A-code	BL67-B-4M12-P
1 x M23, 12 pole, female	BL67-B-1M23



H Series ISO & Network Connectivity Turck Network Portal

I/O modules	Voltage	Part number
4 PNP input module	7 to 30 VDC	BL67-4DI-P
4 PNP input module, with diagnostics	7 to 30 VDC	BL67-4DI-PD
4 NPN input module	24 VDC	BL67-4DI-N

Base module	Part number
4 x M8, 3 pole, female	BL67-B-4M8
2 x M12, 5 pole, female, A-code	BL67-B-2M12
2 x M12, 5 pole, female, A-code	BL67-B-2M12-P
4 x M12, 5 pole, female, A-code	BL67-B-4M12
1 x M23, 12 pole, female	BL67-B-1M23



D

Digital Output Modules

I/O modules	Output current	Part number
8 PNP output module	0.5 amps per channel	BL67-8DO-0.5A-P
8 NPN output module	0.5 amps per channel	BL67-8DO-0.5A-N



Base module	Part number
8 x M8, 3 pole, female	BL67-B-8M8
4 x M12, 5 pole, female, A-code	BL67-B-4M12
4 x M12, 5 pole, female, A-code	BL67-B-4M12-P
1 x M23, 12 pole, female	BL67-B-1M23



I/O modules	Output Current	Part number
4 PNP output module	0.5 amps per channel	BL67-4DO-0.5A-P
4 PNP output module	2 amps per channel	BL67-4DO-2A-P
4 PNP output module	4 amps per channel	BL67-4DO-4A-P
4 NPN output module	2 amps per channel	BL67-4DO-2A-N

Base module	Part number
4 x M8, 3 pole, female	BL67-B-4M8
2 x M12, 5 pole, female, A-code	BL67-B-2M12
2 x M12, 5 pole, female, A-code	BL67-B-2M12-P
4 x M12, 5 pole, female, A-code	BL67-B-4M12
1 x M23, 12 pole, female	BL67-B-1M23



Subbase & Manual
Valves

H Series
Micro

Modulflex
Series

H Series
ISO

Network
Connectivity

DX ISOMAX
Series

Valvair II
Series

Most popular.



For inventory, lead times, and kit lookup, visit www.pdnplu.com

D216

Parker Hannifin Corporation
Pneumatic Division
Richland, Michigan
www.parker.com/pneumatics

Part Numbers

Digital Output Modules

I/O modules	Output current	Part number
16 PNP output module	0.14 amps per channel	BL67-16DO-0.1A-P

Base module	Part number
 1 x M23, 19 pole, female	BL67-B-1M23-19

Relay Output Modules

I/O modules	Output current	Part number
8 normally open relays	0.14 amps per channel	BL67-8DO-R-NO

Base module	Part number
 4 x M12, 5 pole, female, A-code	BL67-B-4M12-P

Analog Input Modules

I/O modules	Input type	Part number
4 configurable current or voltage analog input module	4 to 20 mA or 0 to 20 mA -10 to +10 VDC or 0 to +10 VDC	BL67-4AI-V/I

Base module	Part number
 4 x M12, 5 pole, female, A-code	BL67-B-4M12

I/O modules	Input type	Part number
2 current analog input module	4 to 20 mA or 0 to 20 mA	BL67-2AI-I
2 voltage analog input module	-10 to +10 VDC or 0 to +10 VDC	BL67-2AI-V
2 temperature analog input module	PT100, PT200, PT500, PT1000, Ni100, Ni1000	BL67-2AI-PT
2 temperature analog input module	Type B, E, J, K, N, R, S, T	BL67-2AI-TC



Base module	Part number
 2 x M12, 5 pole, female, A-code	BL67-B-2M12

 Most popular.

H Series ISO & Network Connectivity Turck Network Portal

Combination Input / Output Modules

I/O modules	Input voltage & output current	Part number
4 PNP output 4 PNP input module, with diagnostics	7 to 30 VDC 0.5 Amps	BL67-4DI4DO-PD
8 PNP configurable input or output module, with diagnostics	7 to 30 VDC 0.5 Amps	BL67-8XSG-PD

Base module	Part number
 8 x M8, 3 pole, female	BL67-B-8M8
 4 x M12, 5 pole, female, A-code	BL67-B-4M12
 4 x M12, 5 pole, female, A-code	BL67-B-4M12-P

Analog Output Modules

I/O modules	Input type	Part number
4 voltage analog output module	-10 to +10 VDC or 0 to +10 VDC	BL67-4AO-V

Base module	Part number
 4 x M12, 5 pole, female, A-code	BL67-B-4M12

I/O modules	Input type	Part number
2 current analog output module	4 to 20 mA or 0 to 20 mA	BL67-2AO-I
2 voltage analog output module	-10 to +10 VDC or 0 to +10 VDC	BL67-2AO-V

Base module	Part number
 2 x M12, 5 pole, female, A-code	BL67-B-2M12

D

Subbase & Manual Valves

H Series Micro

Modulflex Series

H Series ISO

Network Connectivity

DX ISOMAX Series

Valvair II Series



For inventory, lead times, and kit lookup, visit www.pdnplu.com



D217

Parker Hannifin Corporation
Pneumatic Division
Richland, Michigan
www.parker.com/pneumatics

Part Numbers

Combination Analog Input / Output Modules

I/O modules	Output current	Part number
4 configurable input and 4 configurable output current or voltage analog module	4 to 20 mA or 0 to 20 mA -10 to +10 VDC or 0 to +10 VDC	BL67-4AI4AO-V/I

Base module	Part number
 8 x M8, 3 pole, female	BL67-B-8M8
 4 x M12, 5 pole, female, A-code	BL67-B-4M12

CANopen Subnet Module

Extender module	Capacity	Part number
1 CANopen connection	64 bits of inputs or outputs	BL67-1CVI

Base module	Part number
 1 x M12, 5 pole, female, A-code	BL67-B-1M12



IO-Link Class A Master

Extender module	Part number
4 master channels	BL67-4IOL

Base module	Part number
 4 x M12, 5 pole, female, A-code	BL67-B-4M12

Power Extender Module

Extender module	Current capacity	Part number
24 VDC field power module	10 amps input	BL67-PF-24VDC

Base module	Part number
 5 pole mini connector to supply bus power and field power	BL67-B-1RSM
 5 pole mini connector to field power only	BL67-B-1RSM-VO
 4 pole mini connector to supply bus power and field power	BL67-B-1RSM-4

 Most popular.



H Series ISO & Network Connectivity Turck Network Portal

I/O modules	Output current	Part number
2 configurable input and 2 configurable output current or voltage analog module	4 to 20 mA or 0 to 20 mA -10 to +10 VDC or 0 to +10 VDC	BL67-2AI2AO-V/I

Base module	Part number
 8 x M8, 3 pole, female	BL67-B-8M8



Serial Interface Module

Extender module	Capacity	Part number
1 RS232 serial interface	300 to 115200 bps	BL67-1RS232
1 RS485 or 422 serial interface	300 to 115200 bps	BL67-1RS485/422

Base module	Part number
 1 x M12, 5 pole, female, A-code	BL67-B-1M12
 1 x M12, 8 pole, female, A-code	BL67-B-1M12-8
 1 x M23, 12 pole, female	BL67-B-1M23

SSI and Counting Modules

Extender module	Capacity	Part number
1 SSI sensor interface	65 kbps up to 1 Mbps	BL67-1SSI
1 counter interface	Up to 250 kHz	BL67-1CNT/ENC

Base module	Part number
 1 x M12, 8 pole, female, A-code	BL67-B-1M12-8
 1 x M23, 12 pole, female	BL67-B-1M23

D

Subbase & Manual
Valves

H Series
Micro

Modulflex
Series

H Series
ISO

Network
Connectivity

DXISOMAX
Series

Valvair II
Series



For inventory, lead times, and kit lookup, visit www.pdnplu.com

Digital PNP Input Modules

DC Input Module	BL67-4DI-P	BL67-8DI-P	BL67-4DI-PD	BL67-8DI-PD
Number of inputs	4	8	4	8
Sensor requirement	PNP Sourcing		PNP Sourcing	
Voltage, on-state input, nom.	24 VDC		24 VDC	
Field power for inputs current consumption	49 mA		109 mA	
Bus power current consumption	30 mA		30 mA	
Low level signal voltage	<4.5 V		<4.5 V	
High level signal voltage	7...30V		7...30V	
Low level signal current	<1.5 mA		<1.5 mA	
High level signal current	2.1...3.7 mA		2.1...3.7 mA	
Type of diagnostics	Group Diagnostics		Channel Diagnostics	
Short circuit protection	Group Protection		Channel Protection	
Input delay	0.25 ms		0.25; 2.5 ms	

PNP (Sourcing)

PNP input modules provide sourcing capabilities. When the input field device is passing, current flows from the input device into the Turck input module.

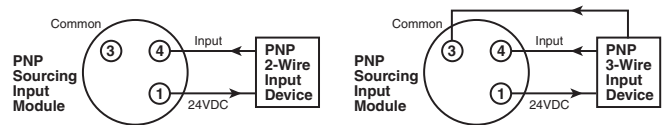

Digital NPN Input Modules

Digital DC Input Module	BL67-4DI-N	BL67-8DI-N
Number of inputs	4	8
Sensor requirement	NPN Sinking	NPN Sinking
Voltage, on-state input, nom.	24 VDC	24 VDC
Field power for inputs current consumption	10 mA	10 mA
Bus power current consumption	30 mA	30 mA
Low level signal voltage	>7 V	>7 V
High level signal voltage	<5 V	<5 V
Low level signal current	<2.5 mA	<1.2 mA
High level signal current	>3 mA	>1.5 mA
Type of diagnostics	Group Diagnostics	Group Diagnostics
Short circuit protection	Group Protection	Group Protection
Input delay	0.25 ms	0.25 ms

NPN (Sinking)

NPN input modules provide sinking capabilities. When the input field device is passing, current out of the Turck input module into the field input device.

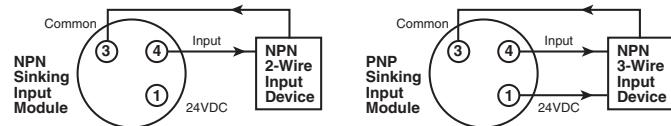

For inventory, lead times, and kit lookup, visit www.pdnplu.com

D219

Parker Hannifin Corporation
 Pneumatic Division
 Richland, Michigan
www.parker.com/pneumatics

D

Subbase & Manual Valves

H Series Micro

Modulflex Series

H Series ISO

Network Connectivity

DX ISOMAX Series

Valvair II Series

Digital PNP Output Modules

Digital DC Output Module	BL67-4DO-0.5A-P	BL67-8DO-0.5A-P	BL67-4DO-2A-P	BL67-16DO-0.1A-P
Number of outputs	4	8	4	16
Sensor requirement	PNP Sourcing	PNP Sourcing	PNP Sourcing	PNP Sourcing
Output voltage	24 VDC	24 VDC	24 VDC	24 VDC
Field power for outputs current consumption	109 mA (Plus load current)	109 mA (Plus load current)	109 mA (Plus load current)	109 mA (Plus load current)
Bus power current consumption	30 mA	30 mA	30 mA	30 mA
Output current per channel	0.5 A	0.5 A	2.0A	0.1 A
Output delay	3 ms	3 ms	3 ms	3 ms
Load type	Resistive, Inductive, Lamp Load	Resistive, Inductive, Lamp Load	Resistive, Inductive, Lamp Load	Resistive, Inductive
Load resistance, resistive	>48 Ohm	>48 Ohm	>12 Ohm	>250 Ohm
Load resistance, inductive	<1.2 H	<1.2 H	<1.2 H	<1.2 H
Lamp load	< 3W	< 3W	< 10W	< 10W
Switching frequency, resistive	<200 Hz	<200 Hz	<200 Hz	<200 Hz
Switching frequency, inductive	< 2 Hz	< 2 Hz	< 2 Hz	< 2 Hz
Switching frequency, lamp load	< 20 Hz	< 20 Hz	< 20 Hz	< 20 Hz
Short-circuit protection	Group Protection	Group Protection	Group Protection	Group Protection
Diagnostic bits	4	8	4	16

PNP (Sourcing)

PNP input modules provide sourcing capabilities. When the input field device is passing, current flows from the input device into the Turck input module.

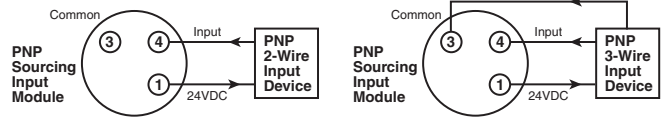

Digital NPN Output Modules

Digital DC Output Module	BL67-8DO-0.5A-N	BL67-4DO-2A-N
Number of outputs	8	4
Sensor requirement	NPN Sinking	NPN Sinking
Output voltage	24 VDC	24 VDC
Field power for outputs current consumption	109 mA (Plus load current)	109 mA (Plus load current)
Bus power current consumption	30 mA	30 mA
Output current per channel	0.5 A	2.0 A
Output delay	3 ms	3 ms
Load type	Resistive, Inductive, Lamp Load	Resistive, Inductive, Lamp Load
Load resistance, resistive	>48 Ohm	>48 Ohm
Load resistance, inductive	<1.2 H	<1.2 H
Lamp load	< 3W	< 3W
Switching frequency, resistive	<200 Hz	<200 Hz
Switching frequency, inductive	< 2 Hz	< 2 Hz
Switching frequency, lamp load	< 20 Hz	< 20 Hz
Short-circuit protection	Group Protection	Group Protection
Diagnostic bits	4	8

NPN (Sinking)

NPN input modules provide sinking capabilities. When the input field device is passing, current out of the Turck input module into the field input device.

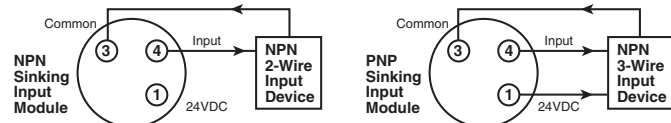

D
 Subbase & Manual Valves
 H Series Micro
 Modutex Series
 H Series ISO
 Network Connectivity
 DX ISOMAX Series
 Valvair II Series



For inventory, lead times, and kit lookup, visit www.pdnplu.com

Relay Output Modules

Relay Output Module	BL67-8DO-R-NO
Number of outputs	8
Output type	Relay
Output voltage	24 VDC
Field power for outputs current consumption	109 mA (Plus load current)
Bus power current consumption	30 mA
Output current per channel	100 mA
Output delay	3 ms
Load type	Resistive, TTL logic
Switching resistor	<31 Ohm
Switching frequency, resistive	<200 Hz
Short-circuit protection	None

Combination Digital Modules

Combination Input and Output Modules	BL67-4DI4DO-PD	BL-67-8XSG-PD
Number of outputs	4	Configurable 0 to 8
Number of inputs	4	Configurable 0 to 8
Total channels	8	8
Sensor requirement	PNP Sourcing	PNP Sourcing
Voltage, on-state input, nom.	24 VDC	24 VDC
Output voltage	24 VDC	24 VDC
Field power for outputs current consumption	109 mA	109 mA
Bus power current consumption	30 mA	30 mA
Input low level signal voltage	<4.5 V	<4.5 V
Input high level signal voltage	7...30V	7...30V
Input low level signal current	<1.5 mA	<1.5 mA
Input high level signal current	2.1...3.7 mA	2.1...3.7 mA
Input delay	0.25; 2.5 ms	0.25; 2.5 ms
Output current per channel	0.5 A	0.5 A
Output delay	3 ms	3 ms
Load type	Resistive, Inductive, Lamp Load	Resistive, Inductive, Lamp Load
Load resistance, resistive	>48 Ohm	>48 Ohm
Load resistance, inductive	<1.2 H	<1.2 H
Lamp load	< 3W	< 3W
Switching frequency, resistive	<200 Hz	<200 Hz
Switching frequency, inductive	< 2 Hz	< 2 Hz
Switching frequency, lamp load	< 20 Hz	< 20 Hz
Short-circuit protection	Channel Protection	Channel Protection
Diagnostic bits	8	12



For inventory, lead times, and kit lookup, visit www.pdnplu.com

D221

Parker Hannifin Corporation
Pneumatic Division
Richland, Michigan
www.parker.com/pneumatics

D

Subbase & Manual Valves

H Series Micro

Moduflex Series

H Series ISO

Network Connectivity

DX ISOMAX Series

Valvair II Series

Analog Input Modules

Analog Input Module	BL67-2AI-I	BL67-2AI-V	BL67-4AI-V/I
Number of inputs	2	2	4
Nominal voltage	24 VDC	24 VDC	24 VDC
Field power for inputs current consumption	22 mA	22 mA	22 mA
Bus power current consumption	35 mA	35 mA	35 mA
Analog input type	0/4...20mA	-10/0...+10 VDC	0/4...20mA or -10/0...+10 VDC
Input resistance	<0.125 kOhm	<98.5 kOhm	<0.125 kOhm or <98.5 kOhm
Maximum limiting frequency	50 Hz		20 Hz
Fault limit @ 23 degree C	<0.2%		<0.3%
Repeatability	0.05%	0.05%	0.05%
Temperature coefficient (ppm/degree C of full scale)	<300	<150	<300
Resolution	16 Bit	16 Bit	16 Bit
Measuring principle	Sigma Delta	Sigma Delta	Sigma Delta
Measured value display	16 bit signed integer, 12 bit full range left justified	16 bit signed integer, 12 bit full range left justified	16 Bit signed integer, 12 bit full range left justified
Diagnostic bits	16		32

Temperature Inputs

Analog Input Module	BL67-2AI-PT	BL67-2AI-TC
Number of inputs	2	2
Nominal voltage	24 VDC	24 VDC
Field power for inputs current consumption	58 mA	40 mA
Bus power current consumption	45 mA	35 mA
Temperature input type	PT100, PT200, PT500, PT1000, Ni100, Ni1000	B, E, J, K, N, R, S, T
Voltage resolution	n/a	+/- 50mV; <2uV
Fault limit @ 23 degree C	<0.2%	<0.2%
Repeatability	0.05%	0.05%
Temperature coefficient (ppm/degree c of full scale)	<300	<300
Resolution	16 Bit	16 Bit
Measured value display	16 bit signed integer, 12 bit full range left justified	16 bit signed integer, 12 bit full range left justified
Diagnostic bits	16	16

D
 Subbase & Manual Valves
 H Series Micro
 Modulflex Series
 H Series ISO
 Network Connectivity
 DXISOMAX Series
 Valvair II Series



For inventory, lead times, and kit lookup, visit www.pdnplu.com

D222

Parker Hannifin Corporation
 Pneumatic Division
 Richland, Michigan
www.parker.com/pneumatics

Analog Input Modules

Analog Input Module	BL67-2AO-I	BL67-2AO-V
Number of inputs	2	2
Nominal voltage	24 VDC	24 VDC
Field power for outputs current consumption	62 mA	67 mA
Bus power current consumption	40 mA	60 mA
Analog output type	0/4...20mA	-10/0...+10 VDC
Output current per channel	n/a	250 mA
Load resistance, resistive	<0.45 kOhm	> 1kOhm
Load resistance, inductive	<1 mH	n/a
Load resistance, capacitive	n/a	> 1 uF
Transmission frequency	<200 Hz	<100 Hz
Fault limit @ 23 degree C	<0.2%	<0.2%
Repeatability	0.05%	0.05%
Temperature coefficient (ppm/degree c of full scale)	<150	<300
Resolution	16 bit	16 bit
Measured value display	16 bit signed integer, 12 bit full range left justified	16 bit signed integer, 12 bit full range left justified

Combination Analog Modules

Analog Combination Module	BL67-4AI4AO-V/I	BL67-2AI2AO-V/I
Number of analog inputs	4	2
Number of analog outputs	4	2
Nominal voltage	24 VDC	24 VDC
Field power for outputs current consumption	67 mA	67 mA
Bus power current consumption	60 mA	60 mA
Analog input type	0/4...20mA or -10/0...+10 VDC	0/4...20mA or -10/0...+10 VDC
Input resistance	0.065 or 225 kOhm	0.065 or 225 kOhm
Maximum limiting frequency	20 Hz	20 Hz
Fault limit @ 23 degree c	<0.3%	<0.3%
Repeatability	0.05%	0.05%
Temperature coefficient (ppm/degree c of full scale)	<300	<300
Resolution	16 bit	16 bit
Measuring principle	Sigma Delta	Sigma Delta
Measured value display	16 bit signed integer, 12 bit full range left justified	16 bit signed integer, 12 bit full range left justified
Analog output type	-10/0...+10 VDC	-10/0...+10 VDC
Output current per channel	250 mA	250 mA
Load resistance, resistive	>1 kOhm	>1 kOhm
Load resistance, capacitive	<1 uF	<1 uF
Transmission frequency	<100 Hz	<100 Hz
Fault limit @ 23 degree C	<0.3%	<0.3%
Repeatability	0.05%	0.05%
Temperature coefficient (ppm/degree c of full scale)	<300	<300
Resolution	16 bit	16 bit
Measured value display	16 bit signed integer, 12 bit full range left justified	16 bit signed integer, 12 bit full range left justified
Diagnostic bits	8	4

D

Subbase & Manual Valves

H Series Micro

Moduflex Series

H Series ISO

Network Connectivity

DX ISOMAX Series

Valvair II Series



For inventory, lead times, and kit lookup, visit www.pdnplu.com

D223

Parker Hannifin Corporation
 Pneumatic Division
 Richland, Michigan
www.parker.com/pneumatics

Power Extender Module

Power Extender Module	BL67-PF-24VDC
Nominal voltage	24 VDC
Field power for outputs current consumption	9 mA
Bus power current consumption	30 mA
Supply for field power for inputs current	4.0 A
Supply for field power for outputs current	10 A
Diagnostic bits	3

RS232 Interface

RS232 Interface	BL67-1RS232
Number of channels	1
Field power for inputs current consumption	90 mA
Bus power current consumption	140 mA
Transmission level active (u rs1)	-15 to -3 VDC
Transmission level inactive (urso)	3 to 15 VDC
Common-mode range (ugl)	-7 to 12 VDC
Transmission signals	RxD, TxD, RTS, CTS
Data buffer received	128 Byte
Send data buffer	64 Byte
Connection type	Full Duplex
Transmission rate	300 to 115200 bps
Parameter	Transmission Rate, Diagnostics, Data Bits, Stop Bits, XON - Character, XOFF - Character, Parity, Flow Control
Cable length	15 m
Diagnostic bits	8

RS485 / 422 Interface

RS485/422 Interface	BL67-1RS485/422
Number of channels	1
Field power for inputs current consumption	42 mA
Bus power current consumption	60 mA
Transmission signals	RxD, TxD
Connection type	2 Wire Half Duplex or 4 Wire Full Duplex
Transmission rate	300 to 115200 bps
Parameter	RS485/422, Transmission Rate, Diagnostics, Data Bits, Stop Bits, XON - Character, XOFF - Character, Parity, Flow Control
Cable length	1000 m
Line impedence	120 Ohm
Bus termination	External
Diagnostic bits	8

D
Subbase & Manual
Valves
H Series
Micro
Modulflex
Series
H Series
ISO
Network
Connectivity
DXISOMAX
Series
Valvair II
Series



For inventory, lead times, and kit lookup, visit www.pdnplu.com

D224

Parker Hannifin Corporation
Pneumatic Division
Richland, Michigan
www.parker.com/pneumatics

SSI Sensor Interface

SSI Sensor Interface	BL67-1SSI
Number of channels	1
Field power for inputs current consumption	39 mA
Bus power current consumption	50 mA
Transmission signals	CL, D
Connection type	4 Wire Full Duplex (Clock Output/Signal Input)
Transmission rate	62.5 kbps up to 1 Mbps
Parameter	Transmission Rate, Diagnostics, Data Format (Binary / GRAY coded), Data Fram Bits (1-32), Number of Invalid Bits (LSB: 0-15, MSB 0-7)
Cable length	30 m
Diagnostic bits	8

Counting Module

Counting Module	BL67-1CNT/ENC
Number of channels	1
Field power for inputs current consumption	109 mA
Bus power current consumption	30 mA
Input type	PNP
Output type	PNP
Output current per channel	0.5 A
Output delay	2 ms
Load type	Resistive
Frequency measurement	Up to 250 kHz
Speed measurement	Factor Configurable
Period duration measurement	2 usec
Upper count limit	0x80000000 up to 0xFFFFFFFF
Lower count limit	0x80000000 up to 0xFFFFFFFF
Short circuit protection	Channel Protection

CANopen Expansion Module

CANopen Expansion Module	BL67-1CVI
Number of channels	1
Field power for inputs current consumption	109 mA
Bus power current consumption	30 mA
Transmission signals	CAN High, CAN Low
Connection type	CANopen
Transmission speed	10 kbps up to 1 Mbps
Parameter	Transmission Rate, Diagnostics, Bus Termination, Range of I/O Data
Bus termination	Internal
Diagnostic bits	48
Max number of CANopen nodes	8
Max processing data per module	8 Byte
Max data per node	4 Byte



For inventory, lead times, and kit lookup, visit www.pdnplu.com

D225

Parker Hannifin Corporation
 Pneumatic Division
 Richland, Michigan
www.parker.com/pneumatics

D

Subbase & Manual Valves

H Series Micro

Modulflex Series

H Series ISO

Network Connectivity

DX ISOMAX Series

Valvair II Series

Power Distribution Options for Turck Network Portal

Turck Communication and I/O Modules - DeviceNet and CANopen, Power Over Network

The 24VDC power supply pins from the DeviceNet or CANopen network connection on the communication module provides a single power circuit. This circuit provides 1.5A bus power, 4A field power for inputs and 8A field power for outputs.

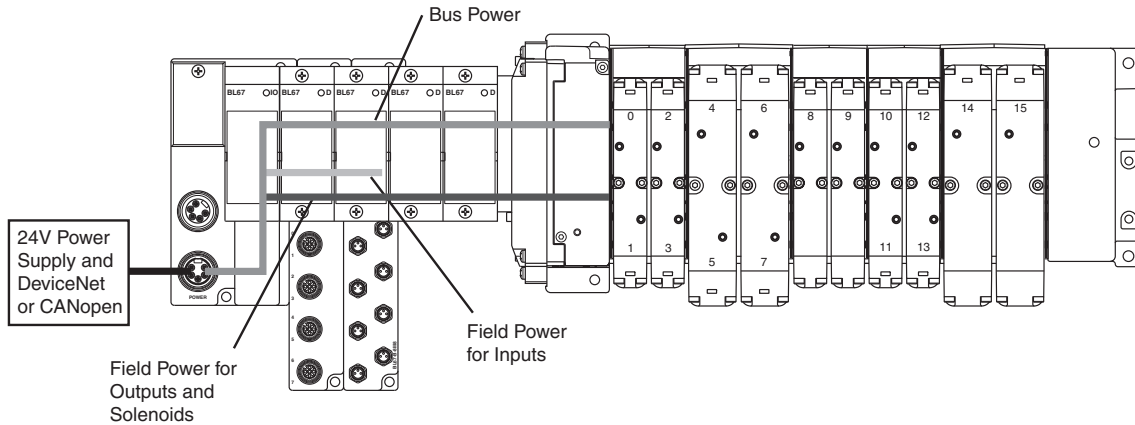

Turck Communication and I/O Modules - EtherNet/IP™, Modbus/TCP, PROFINET, PROFIBUS, and CANopen

An auxiliary 24VDC power supply from the communication module provides power across two separate circuits. The first circuit provides 1.5A bus power and 4A field power for inputs. The second circuit provides 10A field power for outputs which can be wired to an e-stop circuit to kill all outputs.

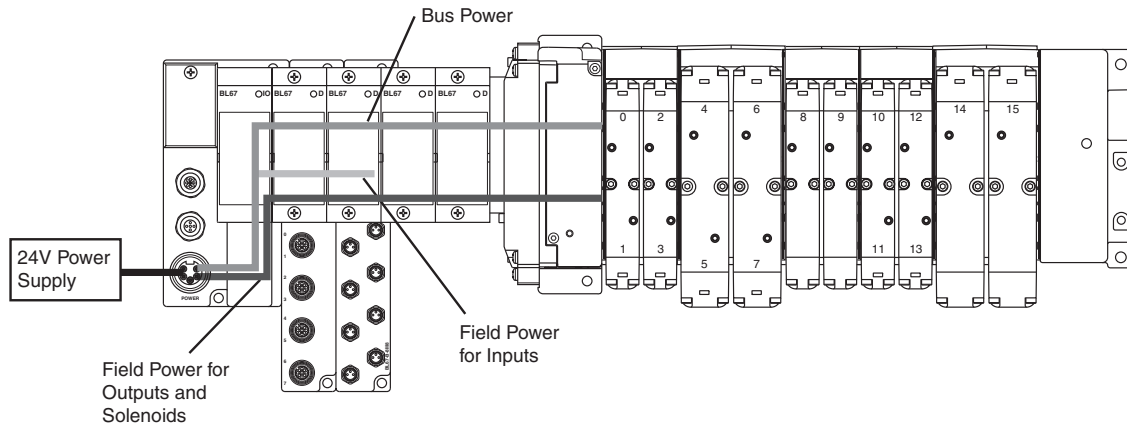

D
Subbase & Manual
Valves
H Series Micro
Modulflex Series
H Series ISO
Network Connectivity
DX ISOMAX Series
Valvair II Series



For inventory, lead times, and kit lookup, visit www.pdnplu.com

D226

Parker Hannifin Corporation
 Pneumatic Division
 Richland, Michigan
www.parker.com/pneumatics

Power Distribution Options for Turk Network Portal (continued)

24VDC Power Extender Module (BL67-PF-24VDC) with Base Module BL67-B-1RSM

This configuration creates an auxiliary 24VDC power supply and provides power across two separate circuits, regardless of the communication module used. The first circuit provides 4A field power for inputs. The second circuit provides 10A field power for outputs which can be wired to an e-stop circuit to kill all outputs and solenoids to the right of the module. The 1.5A bus power is uninterrupted, and is still supplied from the communication module.

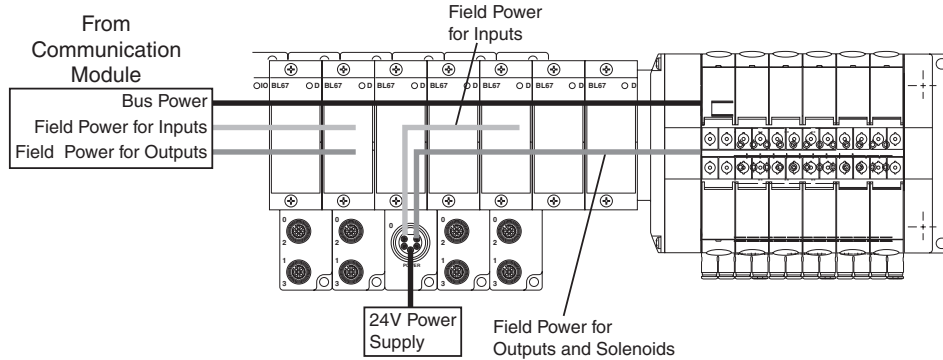

24VDC Power Extender Module (BL67-PF-24VDC) with Base Module BL67-B-1RSM-4

This configuration creates an auxiliary 24VDC power supply and provides power across one circuit, regardless of the communication module used. This circuit provides 4A field power for inputs and 10A field power for outputs. The 1.5A bus power is uninterrupted, and is still supplied from the communication module.

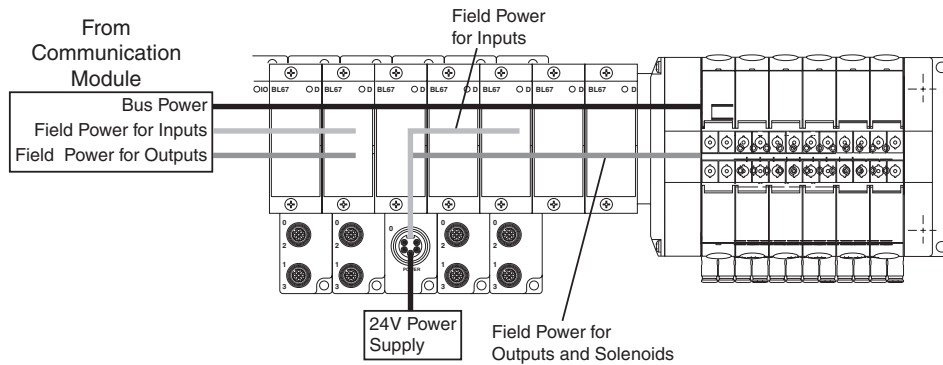

24VDC Power Extender Module (BL67-PF-24VDC) with Base Module BL67-B-1RSM-VO

This configuration creates an auxiliary 24VDC power supply and provides power across one circuit, regardless of the communication module used. This circuit provides 10A field power for outputs which can be wired to an e-stop circuit to kill all outputs and solenoids to the right of the module. The 1.5A bus power and 4A field power for inputs are uninterrupted, and are still supplied from the communication module.

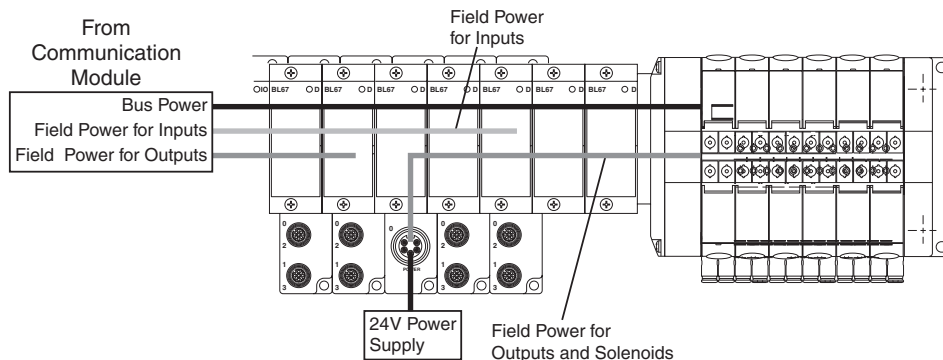

For inventory, lead times, and kit lookup, visit www.pdnplu.com

D227

Parker Hannifin Corporation
 Pneumatic Division
 Richland, Michigan
www.parker.com/pneumatics

D

Subbase & Manual Valves

H Series Micro

Modulflex Series

H Series ISO

Network Connectivity

DX ISOMAX Series

Valvair II Series

7/8" Mini Power Cables - P2H Network Node, H Series Network Portal, Turck Network Portal

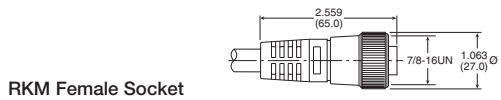

RKM Female Socket

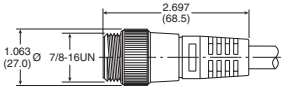

RSM Male Pins

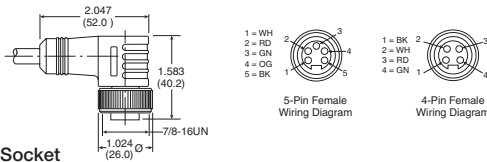

WKM Female Socket

Description	Part number
4-pin female to flying lead cable, 5 meters, TPE	RKM 46-5M/S1587
5-pin female to flying lead cable, 5 meters, TPE	RKM 56-5M/S1587
4-pin male to female cable, TPE	RSM RKM 46-x/S1587
5-pin male to female cable, TPE	RSM RKM 56-x/S1587
4-pin right angle female to flying lead cable, 5 meters, TPE	WKM 46-5M/S1587
5-pin right angle female to flying lead cable, 5 meters, TPE	WKM 56-5M/S1587

Where x = 2, 4, 5, 6, 8, 10 meter standard lengths

Power Tee - P2H Network Node, H Series Network Portal, Turck Network Portal

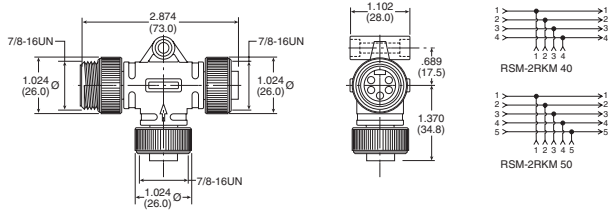

Description	Part number
4-pin Male to 2 female sockets	RSM-2RKM 40
5-pin Male to 2 female sockets	RSM-2RKM 50

D
 Subbase & Manual Valves
 H Series Micro
 Modulflex Series
 H Series ISO
 Network Connectivity
 DX ISOMAX Series
 Valvair II Series

M12 A-code Cables - P2M IO-Link, P2H IO-Link, H Series IO-Link Network Portal, Turck IO-Link Network Portal

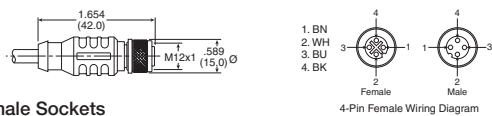

RKC Female Sockets

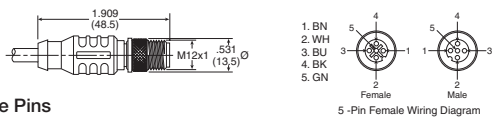

RSC Male Pins

Description	Part number
4-pin female to flying lead cable, PVC	RKC 4.4T-1
4-pin male to flying lead cable, PVC	RSC 4.4T-*
4-pin male to female cable, PVC	RKC 4.4T-*/RSC 4.4T
5-pin female to flying lead cable, TPE	RKC 4.5T-*/S1587
5-pin male to flying lead cable, TPE	RSC 4.5T-4/S1587
5-pin male to female cable, TPE	RKC 4.5T-*/RSC 4.5T/S1587

Where * = 1, 2, 3, 4 meter standard lengths

M8 Cables - H Series IO-Link Network Portal, Turck IO-Link Network Portal

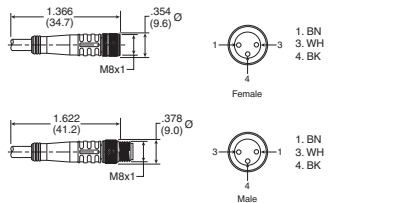

Description	Part number
3-pin female to flying lead cable, PUR	PKG 3M-4/S90
3-pin male to flying lead cable, PUR	PSG 3M-*/S90
3-pin male to female cable, PUR	PKG 3M-*/PSG 3M/S90

Where * = 1, 2, 3, 4 meter standard lengths

Most popular.



For inventory, lead times, and kit lookup, visit www.pdnplu.com

M23 Cables

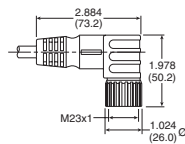
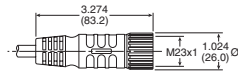

Description	Part number
12-pin, double ended female thread with male pins and female socket, PUR. Pinout optimized for H Series Network Portal.	CSCM CKCM 12-11-x/S90
19-pin, double ended female thread with male pins and female socket, PUR. Pinout optimized for H Series Network Portal.	CSM CKM 19-19-x/S90
19-pin, 90° double ended female thread with male pins and female socket, PUR. Pinout optimized for Turck Network Portal.	CSWM CKWM 19-19-x/CS12852

Where x = 1, 2, 3, 4 meter standard lengths

PROFIBUS Cables - P2M Network Node, Turck Network Portal

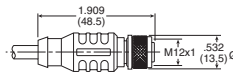
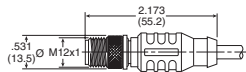

Description	Part number
M12 male to M12 female, PUR	RSSW RKSX 455-xM

Where x = 2, 4, 5, 6, 8, 10 meter standard lengths

RSSW Side, Male Pins

RKSX Side, Female Sockets

PROFIBUS Terminating Resistor - P2M Network Node, Turck Network Portal

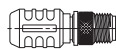

Male Pins

Description	Part number
M12 male pin terminating resistor	P8BPA00MB

Ethernet Cables - P2M Network Node, H Series Network Portal, Turck Network Portal

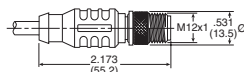
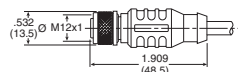

RKSD Side, Female Sockets

RSSD Side, Male Pins

Description	Part number
M12 female to M12 male, PUR	RSSD RKSD 443-xM
RJ45 to M12 male, PUR	RSSD RJ45S 443-2M

Where x = 2, 5, 10, 15, 20, 30 meter standard lengths

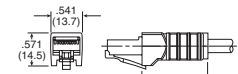

RJ45S Side

25-pin, D-Sub Cable (Female)

Description	Length	Part number
25-pin, D-sub cable, IP20, PUR	3 meters	P8LMH25M3A
25-pin, D-sub cable, IP20, PUR	9 meters	SCD259D
25-pin, D-sub cable, IP65, PUR	3 meters	SCD253W
25-pin, D-sub cable, IP65, PUR	9 meters	SCD259WE

Most popular.



For inventory, lead times, and kit lookup, visit www.pdnplu.com

D229

Parker Hannifin Corporation
Pneumatic Division
Richland, Michigan
www.parker.com/pneumatics

D

Subbase & Manual Valves

H Series Micro

Modulflex Series

H Series ISO

Network Connectivity

DX ISOMAX Series

Valvair II Series

Accessories, Cables & Cordsets

DeviceNet and CANopen Cables - P2M Network Node, H Series Network Portal, Turck Network Portal

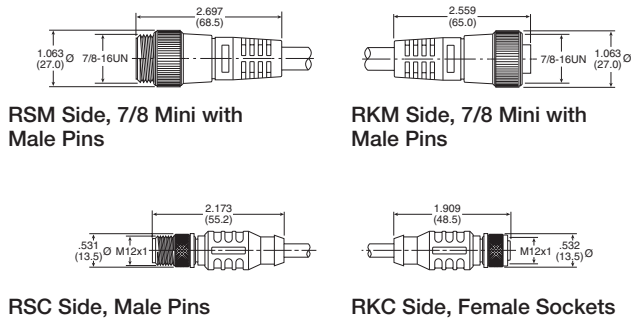

Description	Part Number
7/8" mini male to 7/8" mini female, PUR	RSM RKM 5711-xM
7/8" mini male to M12 female, PUR	RSM RKC 5711-xM
M12 male to M12 female, PUR	RSC RKC 5711-xM
M12 male to 7/8" mini female, PUR	RSC RKM 5711-xM

Where x = 2, 4, 5, 6, 8, 10 meter standard lengths

Bus Power Tee - P2M Network Node, H Series Network Portal, Turck Network Portal

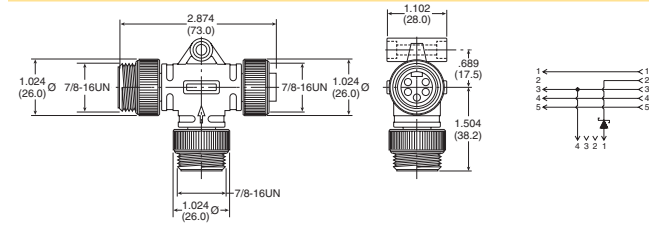

Description	Part Number
Bus power tee	RSM RKM 57 WSM 40 PST

For systems not equipped with Power over network, combines separate network and power feeds into the communication module. Includes reverse current protection

DeviceNet & CANopen Terminating Resistor - P2M Network Node, H Series Network Portal, Turck Network Portal

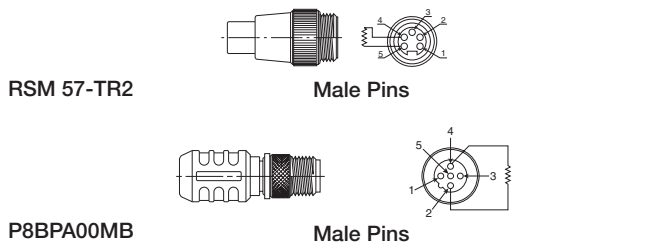

Description	Part Number
7/8" Mini Male Pin Terminating Resistor	RSM 57-TR2
M12 Male Pin Terminating Resistor	P8BPA00MA

M12 Power Splitter - PCH Network Portal, H Series Network Portal, Turck Network Portal, P2M IO-Link, P2H IO-Link

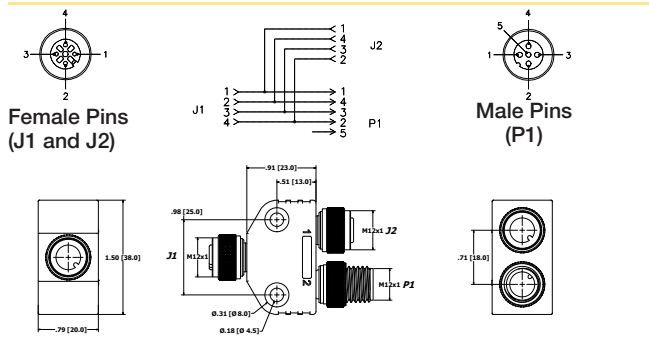

Description	Part Number
M12 Parallel Splitter	100010909

Most popular.



For inventory, lead times, and kit lookup, visit www.pdnplu.com

D230

Parker Hannifin Corporation
Pneumatic Division
Richland, Michigan
www.parker.com/pneumatics

D
 Subbase & Manual Valves
 H Series Micro
 Modutex Series
 H Series ISO
 Network Connectivity
 DX ISOMAX Series
 Valvair II Series

Turck with H Series ISO Valves

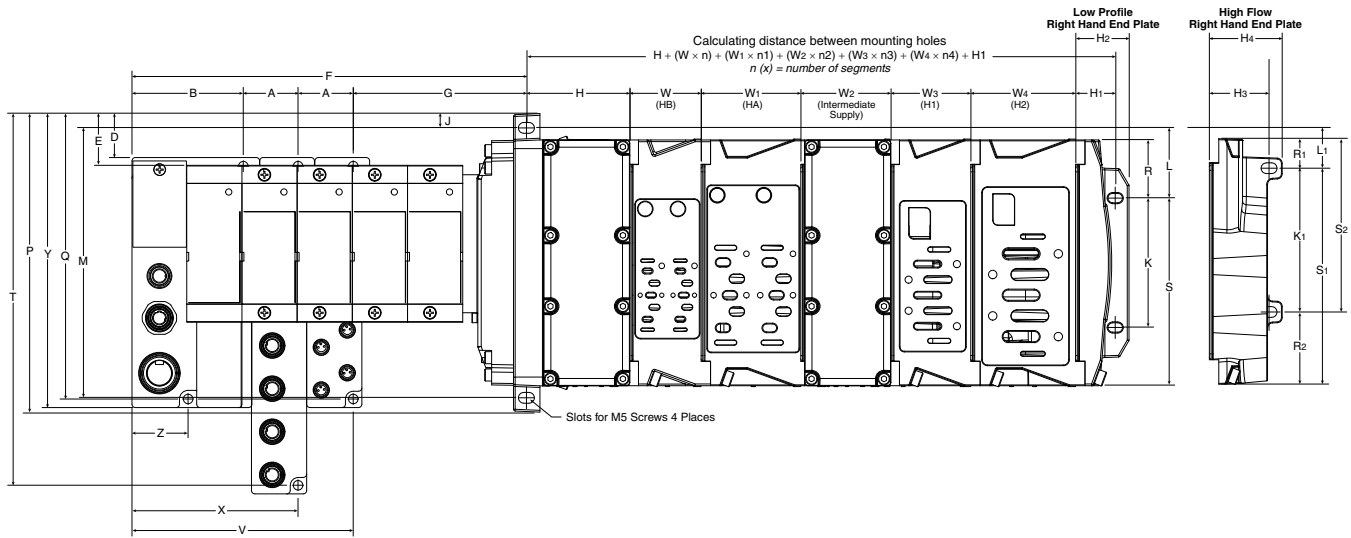

$n(x)$ = number of segments

A	B	D	E	F	G	H	H1	H2	H3	H4	J
1.26 (32.0)	2.54 (64.5)	1.00 (25.4)	1.18 (29.9)	8.99 (228.4)	3.94 (100.1)	2.36 (60.0)	0.90 (23.0)	1.22 (31.0)	1.36 (34.6)	1.66 (42.3)	0.33 (8.3)
K	K1	L	L1	M	P	Q	R	R1	R2	S	S1
2.95 (75.0)	3.28 (83.4)	1.60 (40.7)	0.96 (24.3)	6.16 (156.5)	6.81 (173.1)	6.51 (165.4)	1.33 (33.7)	0.68 (17.3)	1.65 (41.8)	4.28 (108.8)	4.93 (125.2)
S2	T	V	W	W1	W2	W3	W4	X	Y	Z	
3.96 (100.7)	8.48 (215.4)	5.05 (128.3)	1.63 (41.3)	2.28 (57.8)	2.06 (52.3)	1.82 (46.3)	2.39 (60.8)	3.79 (96.3)	6.71 (170.4)	1.28 (32.5)	

Inches (mm)

H3 Manifold Assembly

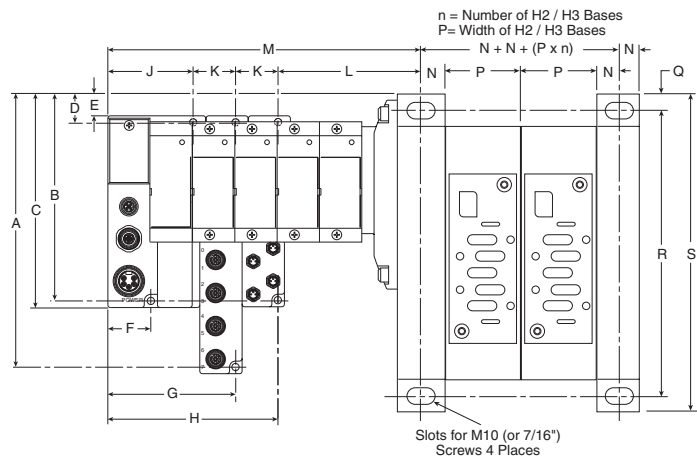

A	B	C	D	E	F	G	H	J	K	L	M	N	P	Q	R	S
8.62 (218.9)	6.65 (168.9)	6.85 (173.9)	1.33 (33.9)	1.14 (28.9)	1.28 (32.5)	3.79 (96.5)	5.06 (128.5)	2.53 (64.5)	1.26 (32)	4.34 (110)	See note 1	.65 (16.5)	2.80 (71)	.59 (15)	10.43 (265)	11.61 (295)

Note 1: $M = J + L + n_2 \times K$, where n_2 = Number of Turck input / output modules
 Inches (mm)



For inventory, lead times, and kit lookup, visit www.pdnplu.com

D231

Parker Hannifin Corporation
 Pneumatic Division
 Richland, Michigan
www.parker.com/pneumatics

D

**Subbase & Manual
 Valves**

**H Series
 Micro**

**Moduflex
 Series**

**H Series
 ISO**

**Network
 Connectivity**

**DX ISOMAX
 Series**

**Valvair II
 Series**