

FLUID CONTROL DIVISION

Parker Hannifin Corporation
95 Edgewood Avenue
New Britain, CT 06051

Telephone (860) 827-2300

Fax (860) 827-2384

IOM 304

(Rev B)



INSTALLATION, OPERATING & MAINTENANCE INSTRUCTIONS 3-WAY NORMALLY CLOSED, 3-WAY NORMALLY OPEN AND 3-WAY UNIVERSAL DIRECT ACTING VALVES SERIES 304



GENERAL SAFETY INSTRUCTIONS BEFORE INSTALLATION

FAILURE OR IMPROPER SELECTION OR IMPROPER USE OF THE PRODUCTS AND/OR SYSTEMS DESCRIBED HEREIN OR RELATED ITEMS CAN CAUSE DEATH, PERSONAL INJURY AND PROPERTY DAMAGE.

Both the conduit coil and leaded one-piece coil contain a green "grounding" wire that must be secured to a proper ground location.

DO NOT cut off the green ground wire. Doing so could negate a proper ground path and leave the valve assembly unprotected or "hot".

This document and other information from Parker Hannifin Corporation, its subsidiaries and authorized distributors provide product and/or system options for further investigation by users having technical expertise. It is important that you analyze all aspects of your application, including consequences of any failure, and review the information concerning the product or system in the current product catalog. Due to the variety of operating conditions and applications for these products or systems, the user, through its own analysis and testing, is solely responsible for making the final selection of the products and systems and assuring that all performance, safety and warning requirements of the application are met.

The products described herein, including without limitation, product features, specifications, designs, availability and pricing, are subject to change by Parker Hannifin Corporation and its subsidiaries at any time without notice.

Carefully read installation, operation and maintenance procedures prior to installing or servicing valve. Do not use valve as a safety shut-off valve when making repairs.

Do not install a valve before depressurizing system down to atmospheric pressure.

Care must be taken to ensure that the valve materials selected are suitable for the media being handled. Parker assumes no liability for damage caused by improper material selection.

Caution: Do not, at any time, make any alteration or modifications to any valve without the express and written approval of Parker's Fluid Control Division.

DESCRIPTION

These valves are 3-way direct operated valves. The 304 series valve product line are available as Normally Closed (N.C.), Normally Open (N.O.), or universal (U) valves. The direct acting valves operate with zero pressure differential.

Valves may be ordered with either NEMA 2, 4, 4X integrated coils for ordinary locations. Additional solenoid coils and enclosures are offered as described in our catalog.

FLUID CODES

Listed below are the common fluid codes. The codes for the approved fluids for use with each valve are printed on the outside of the individual packaging.

<u>CODE</u>	<u>FLUID</u>
A	- Air or nontoxic, nonflammable gases
AC	- Acetylene
G	- City gas supplied by public utilities
GA	- Gasoline
HO	- Petroleum based oils having viscosities up to 400SSU at 38°F
02	- No1 and No 2 fuel oils with viscosities less than 40SSU at 38°C
OX	- Oxygen
W	- Water or other aqueous nonflammable liquids

For the maximum fluid temperatures, as well as valve ambient limitations, check the valve part number on the nameplate and refer to the catalog.

PORT MARKING ARRANGEMENT

Function		Over Seat Body Flow	Under Seat Body Flow	Sleeve	De-Energized	Energized
3-way normally closed	Marking	2	1	3		
	Function	Cyl	Inlet	Exhaust		
3-way normally open	Marking	2	1	3		
	Function	Cyl	Exhaust	Inlet		
3-way universal	Marking	2	1	3		
	Function	Common	NC	NO		

TORQUE CHART

Part Name	Torque Value (inch pounds)	Torque Value (Newton Meters)
Coil Retaining Nut to Sleeve	25 – 35	2.9 – 4.0
Sleeve Assembly into Body	70 - 80	8.0 – 9.2

INSTALLATION INSTRUCTIONS

Installation must be done according to all applicable Safety Codes and Standards and by qualified personnel.

Inspect valve prior to installation. Damaged valves or actuators must not be installed.

Mounting position and pressure limits: Valves can be mounted directly on piping or by using the two #8-32 UNF threaded holes in the bottom of the valve body for the 1/8" NPT valves. Two #10-32 UNF threaded holes for the 1/4" NPT valves. The valves are designed to operate in any position. The valve may be installed in any line regardless of the direction in which the line runs. However, for optimum life and performance, the valve should be mounted vertically upright so as to minimize wear and reduce the possibility of foreign matter accumulating inside the sleeve area.

Line pressure, voltage and frequency must conform to nameplate rating. Allow adequate clearance above valve for removal of coil.

WARNING: Do not install a valve whose permitted pressure / temperature ratings are inadequate to meet the operating conditions.

Piping: Remove protective closures from the ports. Connect line pressure to the inlet port and apparatus piping to the outlet port. Use of Teflon™ tape, threaded compounds or sealants is permissible but should be applied sparingly to male pipe threads only.

CAUTION: Do not allow foreign particles, Teflon tape, or thread compound to enter valve. Only the wrench flats provided on the body ports should be used in applying the torque. Ports should not be subjected to excessive torque by use of an oversized wrench, wrench extension or by impacting the wrench handle. Do not use the valve to "stretch" or "align" the pipe. Tightening torque should not exceed 100 in-lbs for 1/8" NPT valves and 175 in-lbs [20,0 Nm] for 1/4" NPT valves. **Do not use sleeve or enclosure as a lever when applying torque.**

Media filtration: For protection of the valve, install a suitable strainer or filter in the inlet side as close to the valve as possible. Dirt or foreign material in the media may cause excessive leakage, wear, or in exceptional cases, malfunction. Clean periodically depending on service conditions.

Lubrication: Lubrication is not required although air line lubrication will substantially increase valve life.

Electrical connection: Electrical supply must conform to nameplate rating. Connect coil leads or terminals to the electrical circuit using standard electrical practices in compliance with local authorities and the National Electrical Code.

Do not power coil until it has been fitted over sleeve and the retaining nut has been installed to prevent possible coil damage from overheating.

WARNING: Turn off electrical power before connecting the valve to the power source.

If the coil assembly is located in an inconvenient orientation, it may be reoriented to facilitate installation. Loosen coil assembly nut, rotate coil assembly to desired position, then retighten the retaining nut with an input torque per chart.

COIL ASSEMBLY

Position coil (as described below) on the sleeve, position and tighten retaining nut into the top of the sleeve assembly using a 5/32" or 5mm hex wrench with an input torque per chart.

If the coil orientation needs to be repositioned to meet installation wiring needs, simply loosen the retaining nut using a 5/32" or 5mm hex wrench, then rotate the coil to the required position and tighten the retaining nut.

NOTE: The one-piece integrated coil assembly contains top and bottom o-ring seals to prevent moisture ingress into the sleeve area. The o-ring seals must be installed correctly for proper functionality.

One-Piece Integrated Coil. The conduit coil meets NEMA 2, 4, 4X classification for ordinary location requirements. Use suitable electrical cabling and conduit materials and components meeting applicable NEMA recommendations.

For both the conduit and leaded one-piece coils, slide one o-ring over and down the sleeve assembly until the o-ring rests on the valve body., Slide the coil over the valve sleeve. Place the second o-ring into the recess located on top of the coil. Affix retaining nut to sleeve and tighten per torque chart. Use suitable electrical cabling for wiring connection.

WARNING: Both the conduit coil and leaded one-piece coil contain a green “grounding” wire that must be secured to a proper ground location. The grounding wire is welded to the internal coil frame providing the approved ground path for the total valve assembly.

DO NOT cut off the green ground wire. Doing so could negate a proper ground path and leave the valve assembly unprotected or “hot”.

One-Piece DIN Coil and various cable option terminations: Loosen cable screw and remove plastic housing from DIN coil. Do not remove the gasket from the DIN spades on the coil. Separate the plastic block from the housing with a small screwdriver to expose the electrical terminations. Feed the lead wires through the conduit hub and attach them to the appropriate screw terminal. For electrical connection within the terminal box, use field wire that is rated for 90° C or greater. Snap the plastic block back into place inside the metal enclosure. Replace the cover and hand-tighten the cover screws. Place the gasket over the DIN spades on the coil and press the terminal box and coil together. Secure the terminal box to the coil using the mounting screw provided.

Slide one o-ring over and down the sleeve assembly until the o-ring rests on the valve body. Slide the DIN coil over the valve sleeve. Place the second o-ring into the recess located on top of the coil. Affix retaining nut to sleeve and tighten per torque chart.

Two-Piece Yoke & Spade Coil with 1/4” tabs: With coil inserted inside of U-shaped metal yoke, slide coil over sleeve. Affix retaining nut to sleeve and tighten per torque chart. Connect spade termination connector to spade tabs on coil.

Two Piece Yoke & Molded Leaded 2-Wire Coil: With coil inserted inside of U-shaped metal yoke, slide coil over sleeve. Affix retaining nut to sleeve and tighten per torque chart. Use suitable electrical cabling for wiring connection.

Two Piece Grommet Housing & Taped 2 Wire Coil: With the taped coil inserted inside the metallic housing, slide coil over sleeve. Affix retaining nut to sleeve and tighten per torque chart. Use suitable electrical cabling for wiring connection.

Coil/enclosure temperature: The direct acting valves are supplied with coils designed for continuous duty service. Normal free space must be provided for proper ventilation. When the coil is energized continuously for long periods of time, the coil assembly will become hot.

The coil is designed to operate permanently under these conditions. Any excessive heating will be indicated by smoking and/or odor of burning coil insulation.

For the maximum valve ambient conditions, as well as the fluid temperatures, check the valve part number on the nameplate and refer to the product catalog to determine the maximum temperatures.

MAINTENANCE

Note: While the valves are design to operate over millions of cycles, depending on service conditions, fluid being used, filtration, and lubrication, it may be required to periodically clean and/or replace worn components to ensure optimum quality performance. See Disassembly Instructions.

CAUTION: *Do not expose plastic or elastomeric materials to any type of commercial cleaning fluid. Parts should be cleaned with a mild soap and water solution.*

If a valve is to be removed from a pipeline carrying hazardous media, the parts of the valve in contact with the hazardous media must be properly cleaned and decontaminated before repairs are performed.

DISASSEMBLY INSTRUCTIONS

WARNING: *Depressurize system and turn off electrical power to the valve before attempting repair. The coil must not be energized unless it is installed on the valve. Otherwise, the coil will overheat and burn out.*

The valve body need not be removed from the line.

CAUTION: *When removing or replacing the sleeve assembly, it may be necessary to provide proper support to prevent the valve from rotating thereby causing damage to piping.*

To remove the coil assembly:

Using a 5/32” or 5mm hex wrench, unscrew the top retaining nut of the coil assembly. The coil assembly can be lifted off the sleeve tube.

To disassemble the pressure vessel:

Use the same 5/32” or 5mm hex wrench turning counterclockwise to remove the sleeve tube. The plunger assembly, return spring and o-ring seal may be removed.

Replacement Parts: When ordering replacement parts kits, specify valve number and voltage from nameplate. Parts kits are available for each valve. Parts included in each kit are marked with an asterisk (X). See exploded views.

PRESSEURE VESSEL REASSEMBLY INSTRUCTIONS

To reassemble the pressure vessel, refer to exploded view drawings. Parts must be replaced in the order shown.

PARTS LIST AND COMPONENT DRAWING

3-WAY NORMALLY CLOSED, NORMALLY OPEN & UNIVERSAL VALVE PARTS LIST		
Qty	Description	Repair
1	Sleeve	
1	Plunger Assembly	X
1	Body	
1	Spring	X
1	O-Ring Flange Seal	X
1	Retaining Nut	
1	Label	
1	Coil Enclosure modular coils shown molded, tab, & grommet coils also	

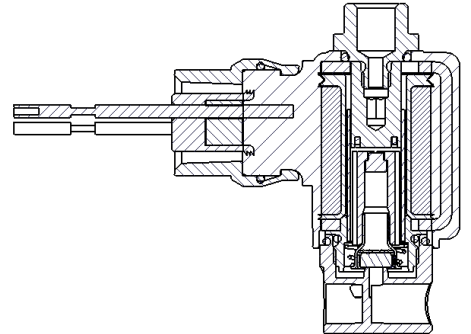

"X" PARTS CONTAINED IN VALVE REPAIR KIT

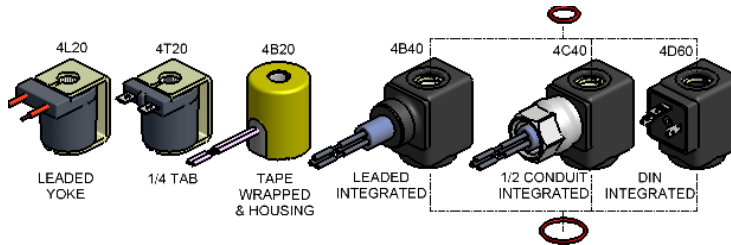

Complete Portfolio of Available Coils

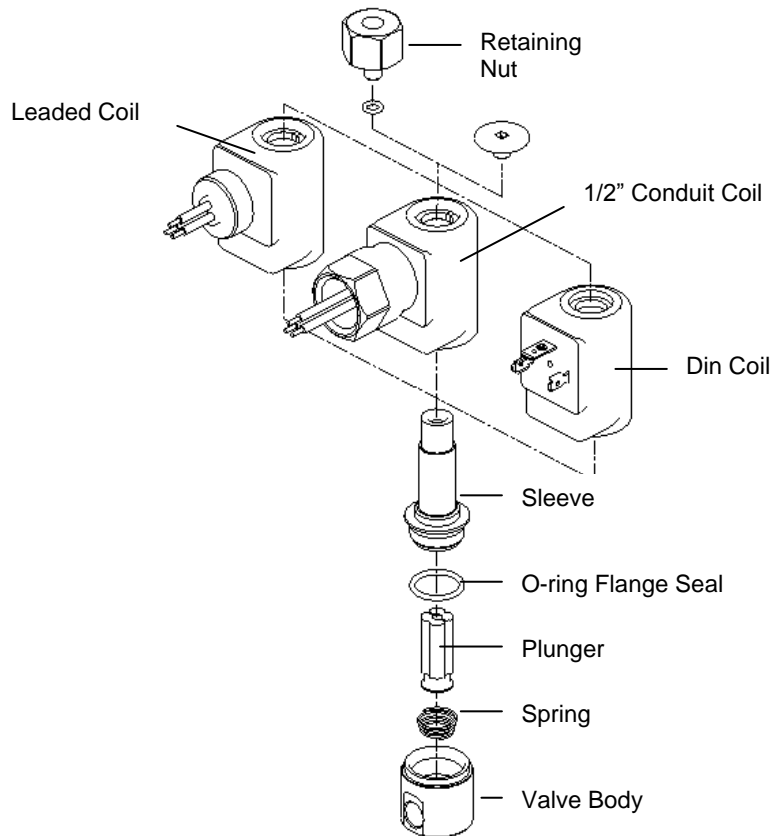

TROUBLE SHOOTING	
PROBLEM	PROCEDURE
Valve fails to operate.	<ol style="list-style-type: none"> 1. Check electrical supply with voltmeter. Voltage must agree with nameplate rating. 2. If supply voltage too low, locate and correct cause of low voltage. Should exceed 85% of rated voltage. 3. Check coil with ohmmeter for shorted or open coil. 4. Make sure pressure complies with label rating. 5. Valve oversized for application. Reference catalog to determine proper valve to meet system capacity.
Valve coil burn-out.	<ol style="list-style-type: none"> 1. Continuous high voltage greater than 10% of rated voltage could result in coil failure. Locate and correct cause of high voltage. 2. Disassemble valve as per the Disassembly Instructions. Check for foreign material lodged in valve. Clean out extraneous matter. The plunger must be free to move without binding. 3. Check electrical wiring installation. 4. Valve located in high ambient temperature. Ventilate or isolate area from high temperatures. May require valve relocation to lower temperature area.
Valve is sluggish or inoperative - electrical supply and pressure check out.	<ol style="list-style-type: none"> 1. Disassemble valve as per the Disassembly Instructions. Clean out extraneous matter. The plunger and spring assembly must be free to move without binding. 2. The plunger spring must not be broken. Replace spring if necessary.
Valve fails to close (normally closed valve).	<ol style="list-style-type: none"> 1. Disassemble valve as per the Disassembly Instructions. Clean out extraneous matter. The plunger must be free to move without binding. 2. With coil de-energized, check power at coil wires. Power should be off. If power is present, correct faulty contacts or wiring.
Valve fails to close (normally open valve).	<ol style="list-style-type: none"> 1. Disassemble valve as per the Disassembly Instructions. Clean out extraneous matter. The retainer guide assembly must be free to move without binding. 2. The pin and spring must be properly inserted in the sleeve assembly. 3. With coil energized, check power at coil wires. Power should be on. If power is present, correct faulty contacts or wiring.
External leakage at sleeve flange to body.	<ol style="list-style-type: none"> 1. Check that sleeve is torqued per torque chart. 2. If leakage persists, remove sleeve and check O-ring seal for damage. Replace if defective.
Internal Leakage.	<ol style="list-style-type: none"> 1. Disassemble valve as per the Disassembly Instructions. Remove extraneous matter. Clean parts in a mild soap and water solution. 2. Examine surface of plunger seal. If damaged, replace plunger. 3. Examine orifice in the body for nicks. Damage may require a new replacement valve.

DECLARATION

Parker's Fluid Control Division certifies its valve appliance products complies with the essential requirements of the applicable European Community Directives. We hereby confirm that the appliance has been manufactured in compliance with the applicable standards and is intended for installation in a machine or application where commissioning is prohibited until evidence has been provided that the machine or application is also in compliance with EC directives.

The data supplied in the Parker valve catalogs and general Installation, Operating & Maintenance Instructions are to be consulted and pertinent accident prevention regulations followed during product installation and use. Any unauthorized work performed on the product by the purchaser or by third parties can impair its function and relieves Parker Hannifin of all warranty claims and liability for any misuse and resulting damage.

A separate Declaration of Conformity or Manufacturer's declaration is available upon request. Please provide valve identification numbers and order serial numbers of products concerned.