

Miller AV Series Heavy Duty Air Cylinders

Catalog M0910-4

January, 2014



**Up to 250 PSI Air Service
Bore Sizes 1" through 14"
17 Mounting Styles**

MHP Series Cylinders
210 BAR



MHP Series cylinders are designed to meet the requirements of ISO 6020/2 (1991), 160 BAR Compact Series. MHP Series cylinders may be used for working pressures up to 210 BAR. Bore sizes from 25mm to 200mm.

VE Series Cylinders
Up to 150 PSI



VE Series Cylinders for Valve Actuation feature a removable rod bushing for easy rod seal service. Optional welded or threaded lift eye. Bore sizes from 2" to 24".

JV Series Cylinders
400-2300 PSI



Our popularly-priced line of medium pressure hydraulic cylinders, with bore sizes from 1" to 8".

HV2 Series Cylinders
3000 PSI



Miller's heavy-duty cylinder line for demanding hydraulic applications. Bore sizes from 1-1/2" to 8".

In line with our policy of continuing product improvement, specifications and information contained in this catalog are subject to change.

Copyright ©2014 by Parker Hannifin Corporation. All rights reserved.

PRINTED IN THE U.S.A.

⚠ WARNING

FAILURE OR IMPROPER SELECTION OR IMPROPER USE OF THE PRODUCTS AND/OR SYSTEMS DESCRIBED HEREIN OR RELATED ITEMS CAN CAUSE DEATH, PERSONAL INJURY AND PROPERTY DAMAGE.

This document and other information from the Parker Hannifin Corporation, its subsidiaries and authorized distributors provide product and/or system options for further investigation by users having expertise. It is important that you analyze all aspects of your application, including consequences of any failure and review the information concerning the product or system in the current product catalog. Due to the variety of operating conditions and applications for these products or systems, the user, through its own analysis and testing, is solely responsible for making the final selection of the products and systems and assuring that all performance, safety and warning requirements of the application are met.

The products described herein, including without limitation, product features, specifications, designs, availability and pricing, are subject to change by Parker Hannifin Corporation and its subsidiaries at any time without notice.

Offer of Sale

The items described in this document are hereby offered for sale by Parker Hannifin Corporation, its subsidiaries or its authorized distributors. This offer and its acceptance are governed by provisions stated on a separate page of the document entitled 'Offer of Sale'.

Miller AV Series Heavy-Duty Air Cylinders

Table of Contents	Page
Specifications, Mounting Styles, Ordering Notes	3
Cylinder Features.....	4, 5
Dimensions 1" to 6" Bore Sizes	
Model 72, Side Lug Mount (NFPA MS2)	6, 7
Model 74, Side Tap Mount (NFPA MS4)	8, 9
Model 61, Head Rectangular Flange Mount (NFPA MF1)	10, 11
Model 62, Cap Rectangular Flange Mount (NFPA MF2).....	12, 13
Model 65, Head Square Flange Mount (NFPA MF5).....	14, 15
Model 66, Cap Square Flange Mount (NFPA MF6).....	14, 15
Model 51, Tie Rods Extended Mountings (Both Ends NFPA MX1, Cap End NFPA MX2, Head End NFPA MX3)	16, 17
Model 81, Head Trunnion Mount (NFPA MT1)	18, 19
Model 82, Cap Trunnion Mount (NFPA MT2).....	20, 21
Model 89, Intermediate Trunnion Mount (NFPA MT4).....	22, 23
Model 84, Cap Fixed Clevis Mount (NFPA MP1)	24, 25
Double Rod End Cylinders.....	26, 27
Dimensions 7" to 14" Bore Sizes	
Model 72, Side Lug Mount (NFPA MS2)	28, 29
Model 74, Side Tap Mount (NFPA MS4)	28, 29
Model 63, Head Square Mount (NFPA ME3).....	30, 31
Model 64, Cap Square Mount (NFPA ME4).....	30, 31
Models 81, 82, and 89 Trunnion Mountings (Head Trunnion NFPA MT1, Cap Trunnion NFPA MT2, Intermediate Trunnion NFPA MT4)	32, 33
Model 84, Cap Fixed Clevis Mount (NFPA MP1).....	34, 35
Model 53 Series, Tie Rods Extended Mountings (Both Ends NFPA MX1, Cap End NFPA MX2, Head End NFPA MX3)	34, 35
Double Rod End Cylinders.....	36, 37
Spherical Bearing Mounting	38 - 41
Spherical Bearing Mounting Accessories.....	42
AVN Non-Lube Cylinder.....	43 - 45
Cylinder Accessories	46 - 49
“Style 9” Piston Rod End – Split Flange Coupling Rod End	50
“Style 9” Piston Rod End – Split Couplers and Weld Plates	51
Linear Alignment Couplers	52
Push and Pull Forces.....	53
Operating Fluids and Temperature Range	54
Ports.....	56
Stroke Tolerance and Cylinder Weights	57
Stop Tubing, Mounting Classes	58
Piston Rod Selection Chart and Data.....	59
Deceleration Force and Air Requirements	60
Air Requirements	61 - 63
Mounting, Parts Identification	65, 66
Parts Identification, Cushion Kits.....	67
Parts Identification, Seal Kits, Standard Seals	68
Parts Identification, Seal Kits, Group 5 Service	69
AVN Series, Seal Kits, Parts Identification	70
How to Select a Miller Cylinder.....	72
How to Order.....	73
Cylinder Safety Guide	74-75
Offer of Sale	76

Miller Fluid Power AV Series Heavy-Duty Air Cylinder



When the job calls for reliable, heavy-duty performance, specify AV Series. A 100,000 psi yield strength chrome-plated, case-hardened piston rod. A 125,000 psi yield strength rod-end stud with rolled threads. 100,000 psi yield strength tie rods. With this construction, Miller Fluid Power AV Series is rated for air service to 250 psi.

They're truly premium quality cylinders, factory prelubricated for millions of maintenance-free cycles...with or without added lubrication. And to make sure every cylinder is premium quality, we subject each and every one – not just batch samples – to tough inspection and performance tests. See inside for the inside story on all the features that make AV Series the high performance, long lasting choice for all your heavy-duty air applications.

Note: Rod diameters over 2¹/₂" will use a threaded bushing.

Miller AV Series Heavy-Duty Air Cylinders

Specifications
Mounting Styles
Ordering Notes

Standard Specifications

- Heavy Duty Service – ANSI/(NFPA) T3.6.7R3-2009 Specifications and Mounting Dimension Standards
 - Standard Construction – Square Head – Tie Rod Design
 - Nominal Pressure – Up to 250 PSI Air Service
 - Standard Fluid – Filtered Air
 - Standard Temperature – -10°F. to +165°F.*
 - Bore Sizes – 1" through 14"
 - Piston Rod Diameter – 1/2" through 5 1/2"
 - Mounting Styles – 14 standard styles
 - Strokes – Available in any practical stroke length
 - Cushions – Optional at either end or both ends of stroke. "Float Check" at cap end. Cushions not available on 1" bore.
 - Rod Ends – Three Standard Choices – Specials to Order
- *See Engineering Section for higher temperature service.

In line with our policy of continuing product improvement, specifications in this catalog are subject to change.

Mounting Styles and Ordering Notes

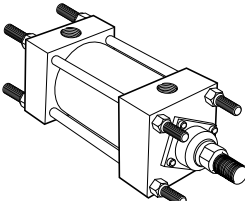
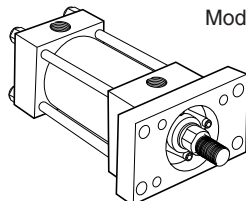
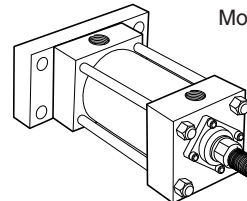
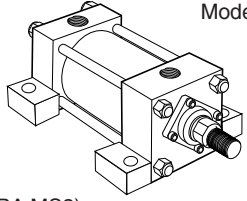
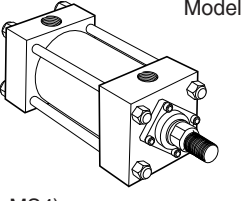
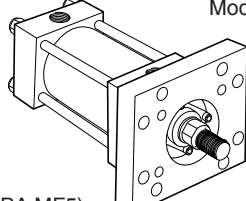
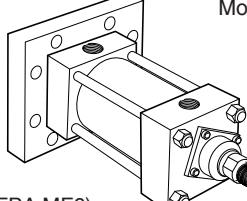
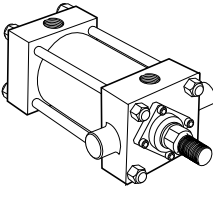
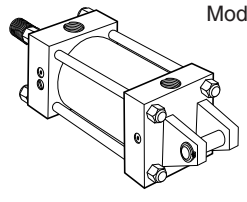
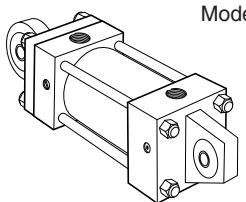
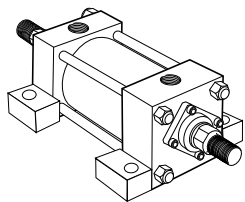
Available in all bore and rod combinations.		Available in all bore and rod combinations through 6" bore. 8"-14" bores supplied as Head Square (Model 63) and Cap Square (Model 64) mounts.																																																																																																																																																												
<p>Tie Rods Extended Both Ends</p>  <p>Both Ends Model 51 Cap End Model 52 Head End Model 53</p> <p>Both Ends (NFPA MX1) Cap End (NFPA MX2) Head End (NFPA MX3)</p>		<p>Head Rectangular Flange</p>  <p>Model 61</p> <p>(NFPA MF1)</p>		<p>Cap Rectangular Flange</p>  <p>Model 62</p> <p>(NFPA MF2)</p>																																																																																																																																																										
<p>Side Lug</p>  <p>Model 72</p> <p>(NFPA MS2)</p>	<p>Side Tap</p>  <p>Model 74</p> <p>(NFPA MS4)</p>	<p>Head Square Flange</p>  <p>Model 65</p> <p>(NFPA MF5)</p>		<p>Cap Square Flange</p>  <p>Model 66</p> <p>(NFPA MF6)</p>																																																																																																																																																										
<p>Trunnion Mounts</p>  <p>Head Model 81 Cap Model 82 Intermediate Model 89</p> <p>Head (NFPA MT1) Cap (NFPA MT2) Intermediate (NFPA MT4)</p>		<p>Rod Bushing Construction</p> <p>B = Bolted Bushing R = Retainer Held Bushing</p> <table border="1"> <thead> <tr> <th>Bore</th> <th>Rod Dia.</th> <th>51 62 74 84</th> <th>52 66 81 89</th> <th>53 72 82 94</th> <th>61 65</th> <th>63 64</th> </tr> </thead> <tbody> <tr> <td>1</td> <td>1/2, 5/8</td> <td></td> <td>R</td> <td></td> <td>R</td> <td>N/A</td> </tr> <tr> <td>1 1/2</td> <td>5/8</td> <td></td> <td>B</td> <td></td> <td>R</td> <td>N/A</td> </tr> <tr> <td rowspan="2">2</td> <td>5/8</td> <td></td> <td>B</td> <td></td> <td>B</td> <td>N/A</td> </tr> <tr> <td>1</td> <td></td> <td>B</td> <td></td> <td>R</td> <td>N/A</td> </tr> <tr> <td rowspan="3">2 1/2</td> <td>1 3/8</td> <td></td> <td>R</td> <td></td> <td>R</td> <td>N/A</td> </tr> <tr> <td>1 3/4</td> <td></td> <td>R</td> <td></td> <td>R</td> <td>N/A</td> </tr> <tr> <td>2</td> <td></td> <td>B</td> <td></td> <td>B</td> <td>N/A</td> </tr> <tr> <td rowspan="3">3 1/4</td> <td>1 3/8</td> <td></td> <td>B</td> <td></td> <td>B</td> <td>N/A</td> </tr> <tr> <td>1 3/4, 2</td> <td></td> <td>B</td> <td></td> <td>R</td> <td>N/A</td> </tr> <tr> <td>2 1/2</td> <td></td> <td>B</td> <td></td> <td>R</td> <td>N/A</td> </tr> <tr> <td rowspan="2">4</td> <td>1 3/8</td> <td></td> <td>B</td> <td></td> <td>B</td> <td>N/A</td> </tr> <tr> <td>1 3/4, 2</td> <td></td> <td>B</td> <td></td> <td>B</td> <td>N/A</td> </tr> <tr> <td rowspan="2">5</td> <td>2 1/2, 3</td> <td></td> <td>B</td> <td></td> <td>R</td> <td>N/A</td> </tr> <tr> <td>3 1/2</td> <td></td> <td>R</td> <td></td> <td>R</td> <td>N/A</td> </tr> <tr> <td rowspan="2">6</td> <td>1 3/8 - 2 1/2</td> <td></td> <td>B</td> <td></td> <td>B</td> <td>N/A</td> </tr> <tr> <td>3 - 4</td> <td></td> <td>R</td> <td></td> <td>R</td> <td>N/A</td> </tr> <tr> <td>7</td> <td>1 3/8, 1 3/4, 2</td> <td></td> <td>B</td> <td></td> <td>N/A</td> <td>B</td> </tr> <tr> <td rowspan="2">8*</td> <td>1 3/8 - 4 1/2</td> <td></td> <td>B</td> <td></td> <td>N/A</td> <td>B</td> </tr> <tr> <td>5, 5 1/2</td> <td></td> <td>B</td> <td></td> <td>N/A</td> <td>B</td> </tr> <tr> <td>10*</td> <td>1 3/4 - 5 1/2</td> <td></td> <td>B</td> <td></td> <td>N/A</td> <td>B</td> </tr> <tr> <td>12*</td> <td>2 - 5 1/2</td> <td></td> <td>B</td> <td></td> <td>N/A</td> <td>B</td> </tr> <tr> <td>14*</td> <td>2 1/2 - 5 1/2</td> <td></td> <td>B</td> <td></td> <td>N/A</td> <td>B</td> </tr> </tbody> </table> <p>*65, 66, 61, 62 not available in these bore sizes.</p>					Bore	Rod Dia.	51 62 74 84	52 66 81 89	53 72 82 94	61 65	63 64	1	1/2, 5/8		R		R	N/A	1 1/2	5/8		B		R	N/A	2	5/8		B		B	N/A	1		B		R	N/A	2 1/2	1 3/8		R		R	N/A	1 3/4		R		R	N/A	2		B		B	N/A	3 1/4	1 3/8		B		B	N/A	1 3/4, 2		B		R	N/A	2 1/2		B		R	N/A	4	1 3/8		B		B	N/A	1 3/4, 2		B		B	N/A	5	2 1/2, 3		B		R	N/A	3 1/2		R		R	N/A	6	1 3/8 - 2 1/2		B		B	N/A	3 - 4		R		R	N/A	7	1 3/8, 1 3/4, 2		B		N/A	B	8*	1 3/8 - 4 1/2		B		N/A	B	5, 5 1/2		B		N/A	B	10*	1 3/4 - 5 1/2		B		N/A	B	12*	2 - 5 1/2		B		N/A	B	14*	2 1/2 - 5 1/2		B		N/A	B
Bore	Rod Dia.	51 62 74 84	52 66 81 89	53 72 82 94	61 65	63 64																																																																																																																																																								
1	1/2, 5/8		R		R	N/A																																																																																																																																																								
1 1/2	5/8		B		R	N/A																																																																																																																																																								
2	5/8		B		B	N/A																																																																																																																																																								
	1		B		R	N/A																																																																																																																																																								
2 1/2	1 3/8		R		R	N/A																																																																																																																																																								
	1 3/4		R		R	N/A																																																																																																																																																								
	2		B		B	N/A																																																																																																																																																								
3 1/4	1 3/8		B		B	N/A																																																																																																																																																								
	1 3/4, 2		B		R	N/A																																																																																																																																																								
	2 1/2		B		R	N/A																																																																																																																																																								
4	1 3/8		B		B	N/A																																																																																																																																																								
	1 3/4, 2		B		B	N/A																																																																																																																																																								
5	2 1/2, 3		B		R	N/A																																																																																																																																																								
	3 1/2		R		R	N/A																																																																																																																																																								
6	1 3/8 - 2 1/2		B		B	N/A																																																																																																																																																								
	3 - 4		R		R	N/A																																																																																																																																																								
7	1 3/8, 1 3/4, 2		B		N/A	B																																																																																																																																																								
8*	1 3/8 - 4 1/2		B		N/A	B																																																																																																																																																								
	5, 5 1/2		B		N/A	B																																																																																																																																																								
10*	1 3/4 - 5 1/2		B		N/A	B																																																																																																																																																								
12*	2 - 5 1/2		B		N/A	B																																																																																																																																																								
14*	2 1/2 - 5 1/2		B		N/A	B																																																																																																																																																								
<p>Cap Fixed Clevis</p>  <p>Model 84</p> <p>(NFPA MP1) Pivot Pin Included</p>	<p>Cap Fixed Eye with Spherical Bearing</p>  <p>Model 94</p> <p>(NFPA MPU3)</p>	<p>Double End Construction</p>  <p>Available in all bore and rod combinations in the following models: 72, 74, 51, 53, 81, 89, and 61 (1" - 6"), 65 (1" - 6") and 63 (8" - 14").</p>																																																																																																																																																												

NOTE: See "How to Order" page for bushing retainer dimensions. Standard pricing applies to "B" and "R" configurations listed above. For alternative construction consult the factory.

The inside story on why AV Series is your best choice in heavy duty air cylinders.

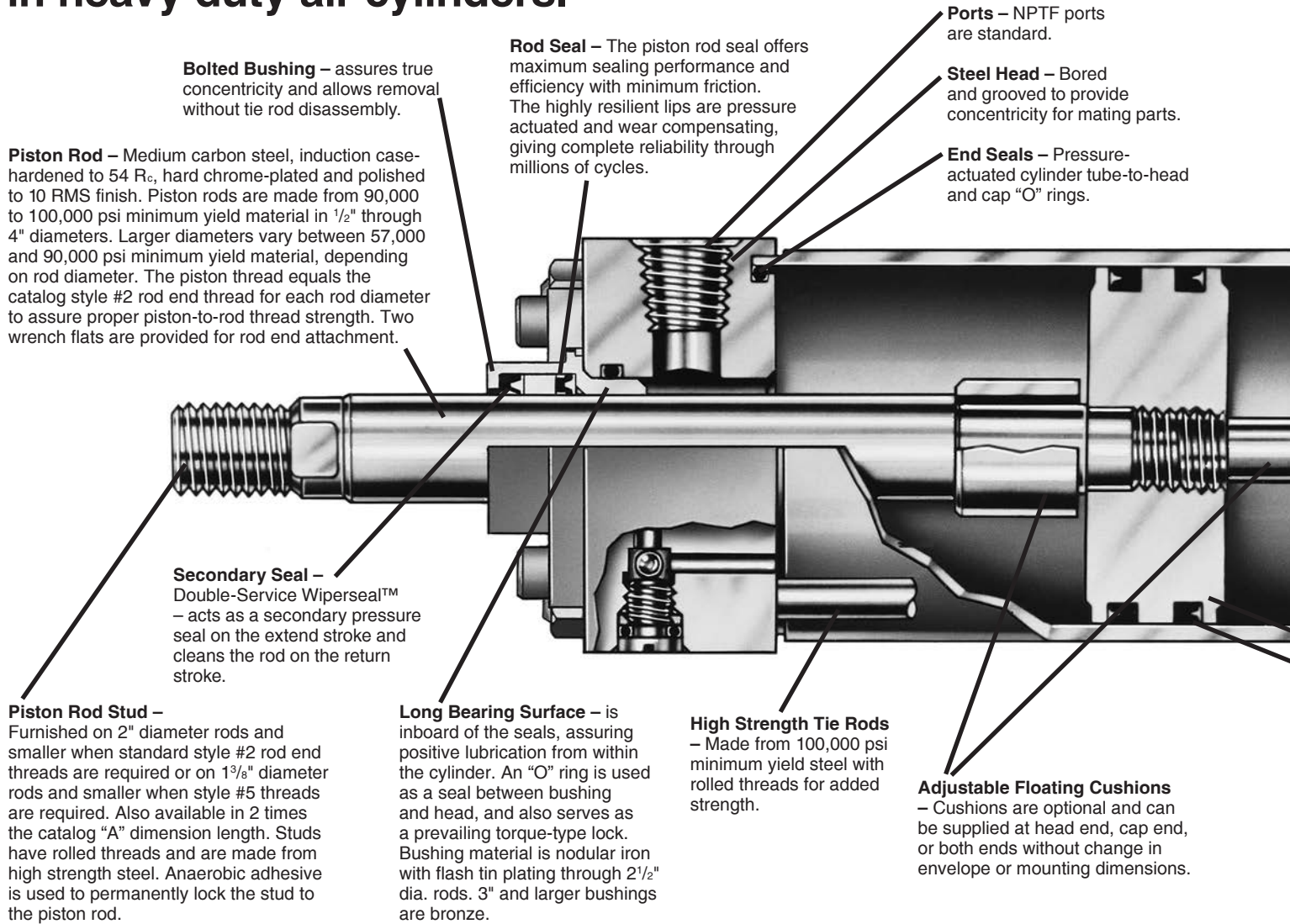

Bolted Bushing – assures true concentricity and allows removal without tie rod disassembly.

Piston Rod – Medium carbon steel, induction case-hardened to 54 Rc, hard chrome-plated and polished to 10 RMS finish. Piston rods are made from 90,000 to 100,000 psi minimum yield material in 1/2" through 4" diameters. Larger diameters vary between 57,000 and 90,000 psi minimum yield material, depending on rod diameter. The piston thread equals the catalog style #2 rod end thread for each rod diameter to assure proper piston-to-rod thread strength. Two wrench flats are provided for rod end attachment.

Secondary Seal – Double-Service Wiperseal™ – acts as a secondary pressure seal on the extend stroke and cleans the rod on the return stroke.

Piston Rod Stud – Furnished on 2" diameter rods and smaller when standard style #2 rod end threads are required or on 1 3/8" diameter rods and smaller when style #5 threads are required. Also available in 2 times the catalog "A" dimension length. Studs have rolled threads and are made from high strength steel. Anaerobic adhesive is used to permanently lock the stud to the piston rod.

Long Bearing Surface – is inboard of the seals, assuring positive lubrication from within the cylinder. An "O" ring is used as a seal between bushing and head, and also serves as a prevailing torque-type lock. Bushing material is nodular iron with flash tin plating through 2 1/2" dia. rods. 3" and larger bushings are bronze.

High Strength Tie Rods – Made from 100,000 psi minimum yield steel with rolled threads for added strength.

Adjustable Floating Cushions – Cushions are optional and can be supplied at head end, cap end, or both ends without change in envelope or mounting dimensions.

Rod Seal – The piston rod seal offers maximum sealing performance and efficiency with minimum friction. The highly resilient lips are pressure actuated and wear compensating, giving complete reliability through millions of cycles.

Ports – NPTF ports are standard.

Steel Head – Bored and grooved to provide concentricity for mating parts.

End Seals – Pressure-actuated cylinder tube-to-head and cap "O" rings.

Adjustable floating cushions

Cushions are optional, and can be supplied at head end, cap end, or both ends without change in envelope or mounting dimensions. Cushions are adjustable.

The AV Series cylinder design incorporates the longest cushion plungers that can be provided in the standard envelope without decreasing the rod bearing and piston bearing lengths.

on the face opposite the needle valve except on models 81, 82 and 89 where it is mounted on side number 3, next to the needle valve. It may be identified by the fact that it is slotted.

d. The check and needle valves are interchangeable in the head.

- (1) When a cushion is specified at the head end:
 - a. A self-centering plunger is furnished on the piston rod assembly.
 - b. A needle valve is provided that is flush with the side of the head when wide open. It may be identified by the fact that it is socket-keyed. It is located on side number 2, in all mountings except 81, 82 and 89. In these models it is located on side number 3.
 - c. A springless check valve is provided that is also flush with the side of the head and is mounted

- (2) When a cushion is specified at the cap end:
 - a. A cushion plunger is provided on the piston rod assembly.
 - b. A "float check" self-centering bushing is provided which incorporates a large flow check valve for fast "out-stroke" action.
 - c. A socket-keyed needle valve is provided that is flush with the side of the cap when wide open. It is located on side number 2 in all mountings except 81, 82 and 89. In these models it is located on side number 3.

Prelubricated Wearing Surfaces

Miller Fluid Power AV Series Air Cylinders are factory prelubricated. Lube-A-Cyl applied to seals, piston, cylinder bore, piston rod and bushing surfaces provides lubrication for normal operation.

Lube-A-Cyl has been field and laboratory tested, and is recommended by Miller Fluid Power for air cylinders where lubricant should remain in the cylinder and not be expelled into the atmosphere.

Piston with Retainer Nut –
Optional at extra charge.

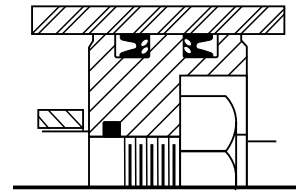

Note: Threaded rod bushings are supplied on cylinders with rod diameters over 2 1/2".

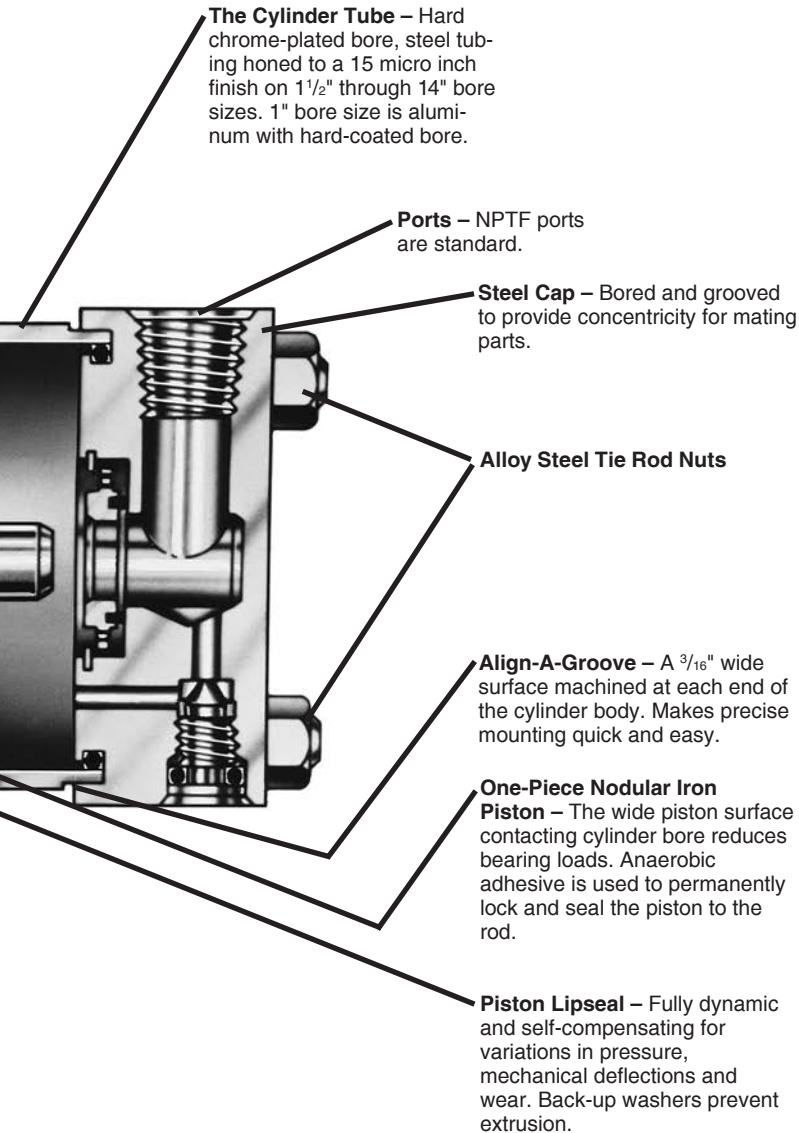

Cushion Length

Cylinder Bore (Inches)	Rod Diameter* (Inches)	Cushion Length (Inches)	
		Head*	Cap
1 1/2	5/8	7/8	13/16
	1	7/8	13/16
2	5/8	7/8	13/16
	1 3/8	7/8	13/16
2 1/2	5/8	7/8	13/16
	1 3/4	7/8	13/16
3 1/4	1	1 1/8	1
	2	1 3/16	1
4	1	1 1/8	1
	2 1/2	1 3/16	1
5	1	1 1/8	1
	3 1/2	1 3/16	1

Cylinder Bore (Inches)	Rod Diameter* (Inches)	Cushion Length (Inches)	
		Head*	Cap
6	1 3/8	1 3/8	1 1/4
	4	1 1/16	1 1/4
7	1 3/8	1 1/16	1 1/4
	2	1 1/16	1 1/4
8	1 3/8	1 1/16	1 1/4
	5 1/2	1 5/16	1 1/4
10	1 3/4	1 5/16	1 3/4
	5 1/2	1 3/16	1 3/4
12	2	1 5/16	1 3/4
	5 1/2	1 3/16	1 3/4
14	2 1/2	1 3/4	2
	5 1/2	1 11/16	2

*Head end cushions for rod diameters not listed have cushion lengths with the limits shown.

NOTE: Cushions not available on 1" bore.

Miller AV Series Heavy-Duty Air Cylinders

Side Lug Mount – 1" to 6" Bore Sizes

Side Lug Mount

Model 72

1" - 1 1/2" - 2" - 2 1/2" - 5" and 6" Bore

With Maximum Oversize Rods

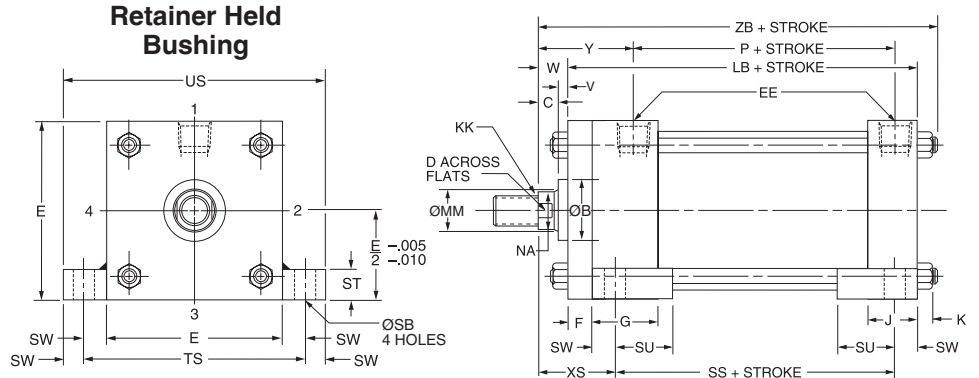
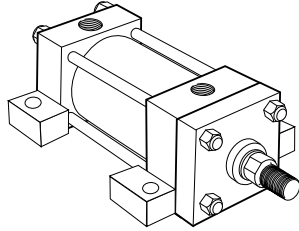

Before determining dimensions: See chart on page 3 for cylinder rod combinations that have removable bushings.

Side Lug Mount

Model 72

1 1/2" - 6" Bore

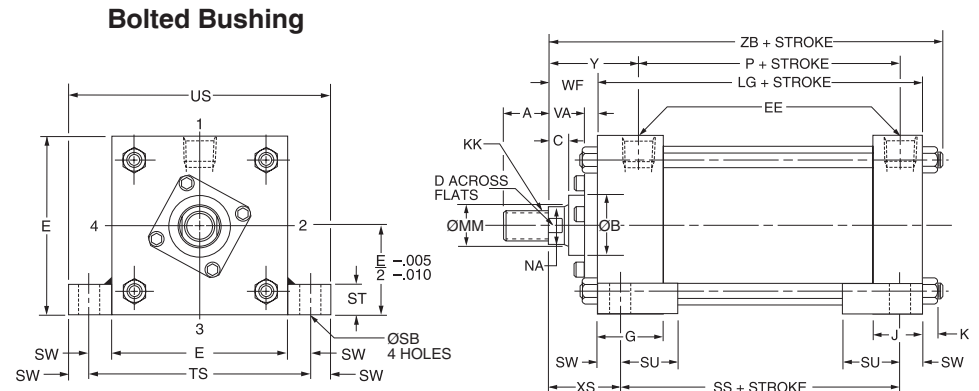
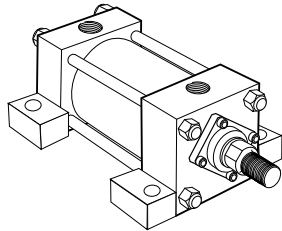

Rod End Dimensions — see table 2

Thread Style 2

Small Male

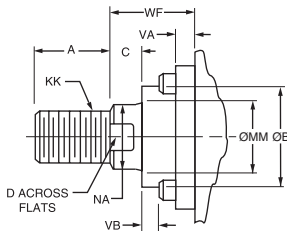

Thread Style 4

Short Female

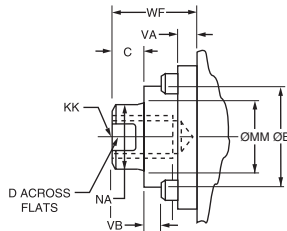

Thread Style 5

Intermediate Male

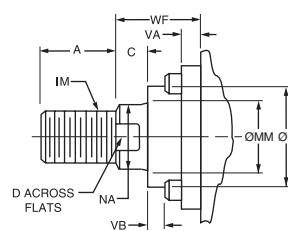

“Special” Thread Style X

Special thread, extension, rod eye, blank, etc., are also available.

To order, specify “Style X” and give desired dimensions for KK, A, W or WF. If otherwise special, furnish dimensioned sketch.

A high strength rod end stud is supplied on thread style 2 through 2" diameter rods and on thread style 5 through 1 3/8" diameter rods. Larger sizes or special rod ends are cut threads. Style 2 rod ends are recommended where the workpiece is secured against the rod shoulder. When the workpiece is not shouldered, style 2 rod ends

are recommended through 2" piston rod diameters and style 5 rod ends are recommended on larger diameters. Use style 4 for applications where female rod ends are required. If rod end is not specified, style 2 will be supplied.

Miller AV Series Heavy-Duty Air Cylinders

Side Lug Mount – 1" to 6" Bore Sizes

Bore	E	EE NPTF	F	G	J	K	SB• (Bolt)	ST	SU	SW	TS	US	Add Stroke			
													LB	LG	P	SS
1	1 1/2	1/4	3/8	1 1/2	1	3/16	1/4	5/16	3/4	5/16	2 3/8	2 3/4	3 7/8	3 1/2	2 1/8	2 7/8
1 1/2	2	3/8	3/8	1 1/2	1	1/4	3/8	1/2	15/16	3/8	2 3/4	3 1/2	4	3 5/8	2 1/4	2 7/8
2	2 1/2	3/8	3/8	1 1/2	1	5/16	3/8	1/2	15/16	3/8	3 1/4	4	4	3 5/8	2 1/4	2 7/8
2 1/2	3	3/8	3/8	1 1/2	1	5/16	3/8	1/2	15/16	3/8	3 3/4	4 1/2	4 1/8	3 3/4	2 3/8	3
3 1/4	3 3/4	1/2	—	1 3/4	1 1/4	3/8	1/2	3/4	1 1/4	1/2	4 3/4	5 3/4	—	4 1/4	2 5/8	3 1/4
4	4 1/2	1/2	—	1 3/4	1 1/4	3/8	1/2	3/4	1 1/4	1/2	5 1/2	6 1/2	—	4 1/4	2 5/8	3 1/4
5	5 1/2	1/2	5/8	1 3/4	1 1/4	7/16	3/4	1	1 9/16	1 1/16	6 7/8	8 1/4	5 1/8	4 1/2	2 7/8	3 1/8
6	6 1/2	3/4	3/4	2	1 1/2	7/16	3/4	1	1 9/16	1 1/16	7 7/8	9 1/4	5 3/4	5	3 1/8	3 5/8

† On 1 1/2", 2" and 2 1/2" bore sizes, the head-end (only) pipe thread is not full depth on cylinders with maximum oversize rods. Minimum of three full threads available.
■ 1" bore head is 1 3/4" x 1 1/2". • Mounting holes are 1/16" larger than bolt size listed.

Table 2—Rod Dimensions and Envelope Dimensions Affected by Rod Size

Bore	MM Rod Ø	Thread		Rod Extensions and Envelope Dimensions Affected By Rod Size													Add Stroke ZB
		Style 5 IM	Style 2 & 4 KK	A	B Ø +.000 -.002	C	D	NA	V	VA	VB	W	WF	XS	Y		
1	1/2	7/16-20	5/16-24	5/8	.999	3/8	3/8	7/16	1/4	—	—	5/8	—	1 5/16	1 15/16	4 11/16	
	5/8	1/2-20	7/16-20	3/4	1.124	3/8	1/2	9/16	1/4	—	—	5/8	—	1 5/16	1 15/16	4 11/16	
1 1/2	5/8	1/2-20	7/16-20	3/4	1.124	3/8	1/2	9/16	—	1/4	3/16	—	1	1 3/8	1 15/16	4 7/8	
	1	7/8-14	3/4-16	1 1/8	1.499	1/2	7/8	15/16	1/2	—	—	1	—	1 3/4	2 5/16	5 1/4	
2	5/8	1/2-20	7/16-20	3/4	1.124	3/8	1/2	9/16	—	1/4	3/16	—	1	1 3/8	1 15/16	4 15/16	
	1 3/8	1 1/4-12	1-14	1 5/8	1.999	5/8	1 1/8	1 5/16	5/8	—	—	1 1/4	—	2	2 9/16	5 9/16	
2 1/2	1	7/8-14	3/4-16	1 1/8	1.499	1/2	7/8	15/16	—	1/4	3/8	—	1 3/8	1 3/4	2 5/16	5 5/16	
	5/8	1/2-20	7/16-20	3/4	1.124	3/8	1/2	9/16	—	1/4	3/16	—	1	1 3/8	1 15/16	5 1/16	
3 1/4	1 3/8	1 1/4-12	1-14	1 5/8	1.999	5/8	1 1/8	1 5/16	5/8	—	—	1 1/4	—	2	2 9/16	5 11/16	
	1 3/4	1 1/2-12	1 1/4-12	2	2.374	3/4	1 1/2	1 11/16	—	1/4	3/8	—	1 3/8	1 7/8	2 7/16	6	
4	1	7/8-14	3/4-16	1 1/8	1.499	1/2	7/8	15/16	—	1/4	3/8	—	1 3/8	1 7/8	2 7/16	6	
	2 1/2	2 1/4-12	1 7/8-12	3	3.124	1	2 1/16	2 3/8	—	1/4	11/16	—	2 1/4	2 3/4	3 5/16	6 7/8	
5	1 3/8	1 1/4-12	1-14	1 5/8	1.999	5/8	1 1/8	1 5/16	—	1/4	1/2	—	1 5/8	2 1/8	2 11/16	6 1/4	
	1 3/4	1 1/2-12	1 1/4-12	2	2.374	3/4	1 1/2	1 11/16	—	1/4	9/16	—	1 7/8	2 3/8	2 15/16	6 1/2	
6	1	7/8-14	3/4-16	1 1/8	1.499	1/2	7/8	15/16	—	1/4	3/8	—	1 3/8	1 7/8	2 7/16	6	
	3 1/2	3 1/4-12	2 1/2-12	3 1/2	4.249	1	3	3 3/8	5/8	—	—	1 5/8	—	2 15/16	3 5/16	7 3/16	
7	1 3/8	1 1/4-12	1-14	1 5/8	1.999	5/8	1 1/8	1 5/16	—	1/4	1/2	—	1 5/8	2 5/16	2 11/16	6 9/16	
	1 3/4	1 1/2-12	1 1/4-12	2	2.374	3/4	1 1/2	1 11/16	—	1/4	9/16	—	1 7/8	2 9/16	2 15/16	6 13/16	
8	1	7/8-14	3/4-16	1 1/8	1.499	1/2	7/8	15/16	—	1/4	3/8	—	1 3/8	1 7/8	2 7/16	6 5/16	
	3 1/2	3 1/4-12	2 1/2-12	3 1/2	4.249	1	3	3 3/8	5/8	—	—	1 5/8	—	2 15/16	3 5/16	7 3/16	
9	1 3/8	1 1/4-12	1-14	1 5/8	1.999	5/8	1 1/8	1 5/16	—	1/4	1/2	—	1 5/8	2 5/16	2 11/16	6 9/16	
	1 3/4	1 1/2-12	1 1/4-12	2	2.374	3/4	1 1/2	1 11/16	—	1/4	9/16	—	1 7/8	2 9/16	2 15/16	6 13/16	
10	1	7/8-14	3/4-16	1 1/8	1.499	1/2	7/8	15/16	—	1/4	3/8	—	1 3/8	1 7/8	2 7/16	6	
	3 1/2	3 1/4-12	2 1/2-12	3 1/2	4.249	1	3	3 3/8	5/8	—	—	1 5/8	—	2 15/16	3 5/16	7 3/16	
11	1 3/8	1 1/4-12	1-14	1 5/8	1.999	5/8	1 1/8	1 5/16	—	1/4	1/2	—	1 5/8	2 5/16	2 11/16	6 9/16	
	1 3/4	1 1/2-12	1 1/4-12	2	2.374	3/4	1 1/2	1 11/16	—	1/4	9/16	—	1 7/8	2 9/16	2 15/16	6 13/16	
12	1	7/8-14	3/4-16	1 1/8	1.499	1/2	7/8	15/16	—	1/4	3/8	—	1 3/8	1 7/8	2 7/16	6	
	3 1/2	3 1/4-12	2 1/2-12	3 1/2	4.249	1	3	3 3/8	5/8	—	—	1 5/8	—	2 15/16	3 5/16	7 3/16	
13	1 3/8	1 1/4-12	1-14	1 5/8	1.999	5/8	1 1/8	1 5/16	—	1/4	1/2	—	1 5/8	2 5/16	2 11/16	6 9/16	
	1 3/4	1 1/2-12	1 1/4-12	2	2.374	3/4	1 1/2	1 11/16	—	1/4	9/16	—	1 7/8	2 9/16	2 15/16	6 13/16	
14	1	7/8-14	3/4-16	1 1/8	1.499	1/2	7/8	15/16	—	1/4	3/8	—	1 3/8	1 7/8	2 7/16	6	
	3 1/2	3 1/4-12	2 1/2-12	3 1/2	4.249	1	3	3 3/8	5/8	—	—	1 5/8	—	2 15/16	3 5/16	7 3/16	
15	1 3/8	1 1/4-12	1-14	1 5/8	1.999	5/8	1 1/8	1 5/16	—	1/4	1/2	—	1 5/8	2 5/16	2 11/16	6 9/16	
	1 3/4	1 1/2-12	1 1/4-12	2	2.374	3/4	1 1/2	1 11/16	—	1/4	9/16	—	1 7/8	2 9/16	2 15/16	6 13/16	
16	1	7/8-14	3/4-16	1 1/8	1.499	1/2	7/8	15/16	—	1/4	3/8	—	1 3/8	1 7/8	2 7/16	6	
	3 1/2	3 1/4-12	2 1/2-12	3 1/2	4.249	1	3	3 3/8	5/8	—	—	1 5/8	—	2 15/16	3 5/16	7 3/16	

Rod End Dimensions — see table 2

Thread Style 2 Small Male

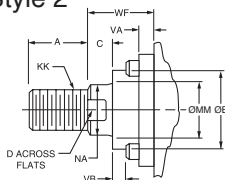

A high strength rod end stud is supplied on thread style 2 through 2" diameter rods and on thread style 5 through 1 3/8" diameter rods. Larger sizes or special rod ends are cut threads. Style 2 rod ends are recommended where the workpiece is secured against the rod shoulder. When the workpiece is not

Thread Style 4 Short Female

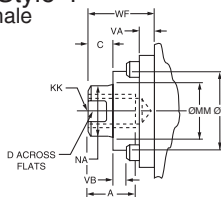

shouldered, style 2 rod ends are recommended through 2" piston rod diameters and style 5 rod ends are recommended on larger diameters. Use style 4 for applications where female rod end threads are required. If rod end is not specified, style 2 will be supplied.

Thread Style 5 Intermediate Male

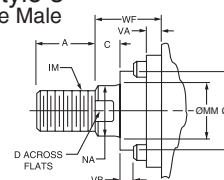

"Special" Thread Style X

Special thread, extension, rod eye, blank, etc., are also available.

To order, specify "Style X" and give desired dimensions for KK, A, W or WF. If otherwise special, furnish dimensioned sketch.

Miller AV Series Heavy-Duty Air Cylinders

Side Tap Mount
1" to 6" Bore Sizes

Side Tap Mount

Model 74

1" - 1 1/2" - 2" - 2 1/2" - 5" and 6" Bore
With Maximum Oversize Rods

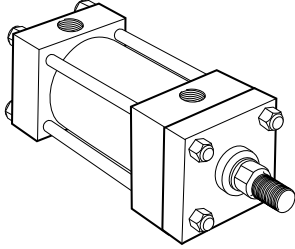

Retainer Held Bushing

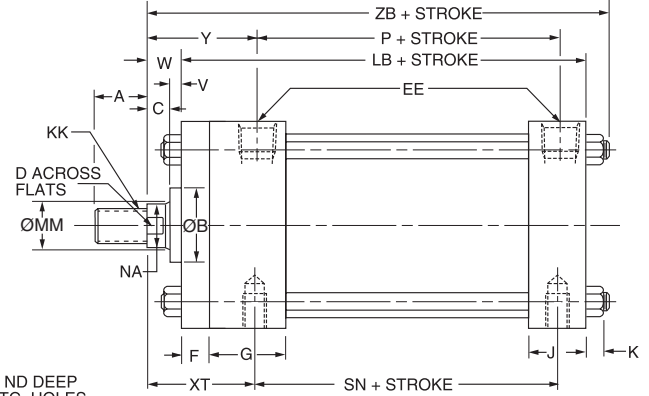
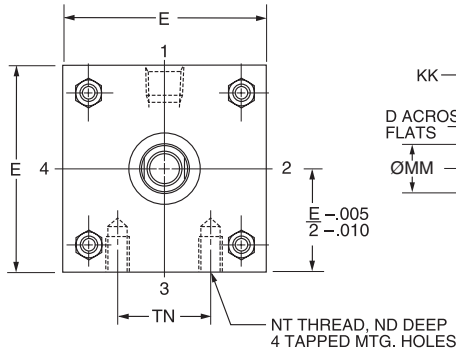

Before determining dimensions: See chart on page 3 for cylinder rod combinations that have removable bushings.

Side Tap Mount

Model 74

1 1/2" - 6" Bore

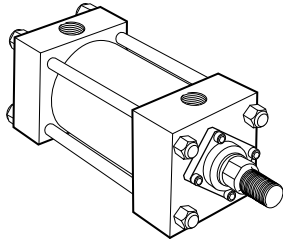

Bolted Bushing

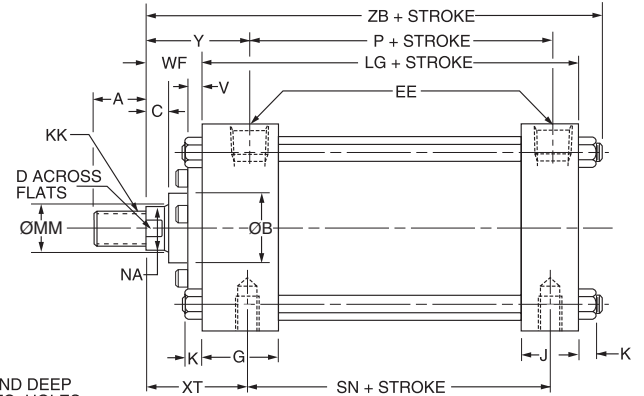
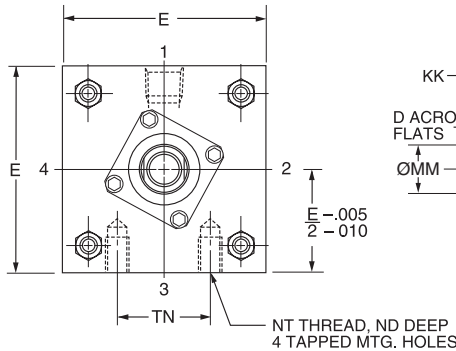

Rod End Dimensions — see table 2

Thread Style 2

Small Male

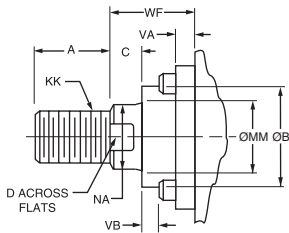

Thread Style 4

Short Female

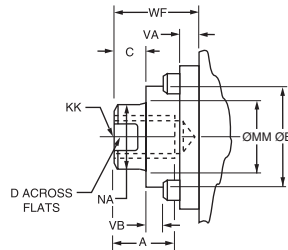

Thread Style 5

Intermediate Male

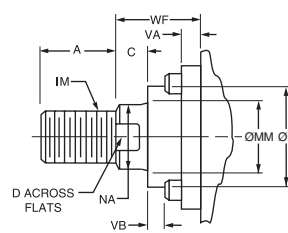

A high strength rod end stud is supplied on thread style 2 through 2" diameter rods and on thread style 5 through 1 3/8" diameter rods. Larger sizes or special rod ends are cut threads. Style 2 rod ends are recommended where the workpiece is secured against the rod shoulder. When the workpiece is not shouldered, style 2 rod ends

are recommended through 2" piston rod diameters and style 5 rod ends are recommended on larger diameters. Use style 4 for applications where female rod end threads are required. If rod end is not specified, style 2 will be supplied.

"Special" Thread Style X

Special thread, extension, rod eye, blank, etc., are also available.

To order, specify "Style X" and give desired dimensions for KK, A, W or WF. If otherwise special, furnish dimensioned sketch.

Miller AV Series Heavy-Duty Air Cylinders

Side Tap Mount
1" to 6" Bore Sizes

Table 1—Envelope and Mounting Dimensions

Bore	E	EE NPTF	F	G	J	K	TN	NT	Add Stroke			
									LB	LG	P	SN
1	■	1/4	3/8	1 1/2	1	3/16	9/16	10-24	3 7/8	—	2 1/8	2 1/8
1 1/2	2	3/8†	3/8	1 1/2	1	1/4	5/8	1/4-20	4	3 5/8	2 1/4	2 1/4
2	2 1/2	3/8†	3/8	1 1/2	1	5/16	7/8	5/16-18	4	3 5/8	2 1/4	2 1/4
2 1/2	3	3/8†	3/8	1 1/2	1	5/16	1 1/4	3/8-16	4 1/8	3 3/4	2 3/8	2 3/8
3 1/4	3 3/4	1/2	—	1 3/4	1 1/4	3/8	1 1/2	1/2-13	—	4 1/4	2 5/8	2 5/8
4	4 1/2	1/2	—	1 3/4	1 1/4	3/8	2 1/16	1/2-13	—	4 1/4	2 5/8	2 5/8
5	5 1/2	1/2	5/8	1 3/4	1 1/4	7/16	2 11/16	5/8-11	5 1/8	4 1/2	2 7/8	2 7/8
6	6 1/2	3/4	3/4	2	1 1/2	7/16	3 1/4	3/4-10	—	5	3 1/8	3 1/8

†On 1 1/2", 2" and 2 1/2" bore sizes, the head-end (only) pipe thread is not full depth on cylinders with maximum oversize rods. Minimum of three full threads available.

■ 1" bore head is 1 3/4" x 1 1/2".

Table 2—Rod Dimensions and Envelope Dimensions Affected by Rod Size

Bore	MM Rod Ø	Thread		Rod Extensions and Envelope Dimensions Affected By Rod Size														Add Stroke
		Style 5 IM	Style 2 & 4 KK	A	B Ø +0.002 -0.002	C	D	NA	V	VA	VB	W	WF	XT	Y	ND	ZB	
																	ZB	
1	1/2	7/16-20	5/16-24	5/8	.999	3/8	3/8	7/16	1/4	—	—	5/8	—	1 5/16	1 5/16	1/4	4 11/16	
	5/8	1/2-20	7/16-20	3/4	1.124	3/8	1/2	9/16	1/4	—	—	5/8	—	1 5/16	1 5/16	1/4	4 11/16	
1 1/2	5/8	1/2-20	7/16-20	3/4	1.124	3/8	1/2	9/16	—	1/4	3/16	—	1	1 5/16	1 5/16	5/16	4 7/8	
	1	7/8-14	3/4-16	1 1/8	1.499	1/2	7/8	1 5/16	1/2	—	—	1	—	2 5/16	2 5/16	5/16	5 1/4	
2	5/8	1/2-20	7/16-20	3/4	1.124	3/8	1/2	9/16	—	1/4	3/16	—	1	1 5/16	1 3/16	11/32	4 5/16	
	1 3/8	1 1/4-12	1-14	1 5/8	1.999	5/8	1 1/8	1 5/16	5/8	—	—	1 1/4	—	2 9/16	2 9/16	11/32	5 9/16	
2 1/2	1	7/8-14	3/4-16	1 1/8	1.499	1/2	7/8	1 5/16	—	1/4	3/8	—	1 3/8	2 5/16	2 5/16	11/32	5 5/16	
	5/8	1/2-20	7/16-20	3/4	1.124	3/8	1/2	9/16	—	1/4	3/16	—	1	1 5/16	1 5/16	7/16	5 1/16	
3 1/4	1 3/4	1 1/2-12	1 1/4-12	2	2.374	3/4	1 1/2	1 11/16	3/4	—	—	1 1/2	—	2 13/16	2 13/16	7/16	5 5/16	
	1	7/8-14	3/4-16	1 1/8	1.499	1/2	7/8	1 5/16	—	1/4	3/8	—	1 3/8	2 5/16	2 5/16	1/2	6	
4	2	1 3/4-12	1 1/2-12	2 1/4	2.624	7/8	1 11/16	1 5/16	—	1/4	9/16	—	2	3 1/16	3 1/16	1/2	6 5/8	
	1 3/8	1 1/4-12	1-14	1 5/8	1.999	5/8	1 1/8	1 5/16	—	1/4	1/2	—	1 5/8	2 11/16	2 11/16	1/2	6 1/4	
5	1 3/4	1 1/2-12	1 1/4-12	2	2.374	3/4	1 1/2	1 11/16	—	1/4	9/16	—	1 7/8	2 5/16	2 5/16	3/4	6 1/2	
	1	7/8-14	3/4-16	1 1/8	1.499	1/2	7/8	1 5/16	—	1/4	3/8	—	1 3/8	2 5/16	2 5/16	5/8	6	
6	2 1/2	2 1/4-12	1 7/8-12	3	3.124	1	2 1/16	2 3/8	—	1/4	1 1/16	—	2 1/4	3 5/16	3 5/16	5/8	6 7/8	
	1 3/8	1 1/4-12	1-14	1 5/8	1.999	5/8	1 1/8	1 5/16	—	1/4	1/2	—	1 5/8	2 11/16	2 11/16	3/4	6 9/16	
7	2	1 3/4-12	1 1/2-12	2 1/4	2.624	7/8	1 11/16	1 5/16	—	1/4	9/16	—	2	3 1/16	3 1/16	3/4	6 15/16	
	1 3/4	1 1/2-12	1 1/4-12	2	2.374	3/4	1 1/2	1 11/16	—	1/4	9/16	—	1 7/8	2 5/16	2 5/16	3/4	6 13/16	
8	2 1/2	2 1/4-12	1 7/8-12	3	3.124	1	2 1/16	2 3/8	—	1/4	1 1/16	—	2 1/4	3 5/16	3 5/16	5/8	7 3/16	
	1 3/8	1 1/4-12	1-14	1 5/8	1.999	5/8	1 1/8	1 5/16	—	1/4	7/16	—	1 5/8	2 13/16	2 13/16	7/8	7 1/16	
9	4	3 3/4-12	3-12	4	4.749	1	3 3/8	3 7/8	1/2	—	—	1 1/2	—	3 7/16	3 7/16	7/8	7 11/16	
	1 3/4	1 1/2-12	1 1/4-12	2	2.374	3/4	1 1/2	1 11/16	—	1/4	9/16	—	1 7/8	3 1/16	3 1/16	7/8	7 5/16	
10	2	1 3/4-12	1 1/2-12	2 1/4	2.624	7/8	1 11/16	1 5/16	—	1/4	9/16	—	2	3 3/16	3 3/16	7/8	7 1/16	
	2 1/2	2 1/4-12	1 7/8-12	3	3.124	1	2 1/16	2 3/8	—	1/4	1 1/16	—	2 1/4	3 7/16	3 7/16	7/8	7 11/16	
11	3	2 3/4-12	2 1/4-12	3 1/2	3.749	1	2 5/8	2 7/8	5/8	—	—	1 1/2	—	3 7/16	3 7/16	7/8	7 11/16	
	3 1/2	3 1/4-12	2 1/2-12	3 1/2	4.249	1	3	3 3/8	1/2	—	—	1 1/2	—	3 7/16	3 7/16	7/8	7 11/16	

Miller AV Series Heavy-Duty Air Cylinders

Head Rectangular Flange Mount
1" to 6" Bore Sizes

Head Rectangular Flange Mount
Model 61
1" - 6" Bore

Bolted
Bushing

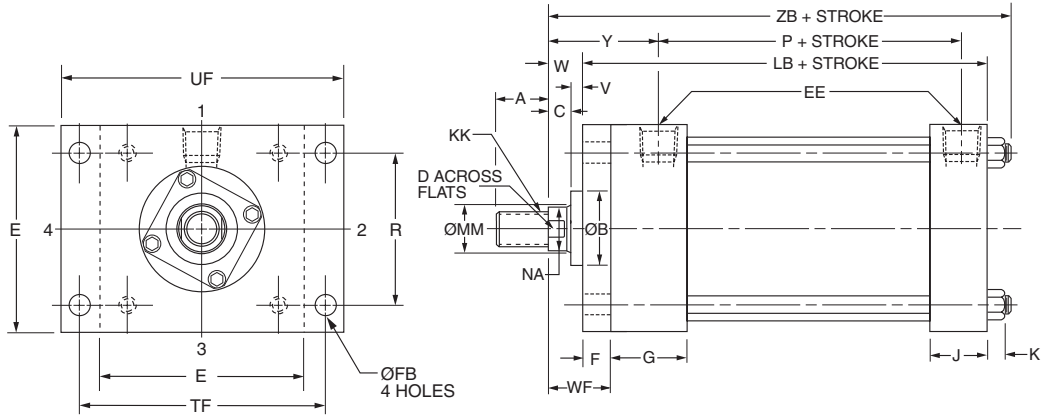
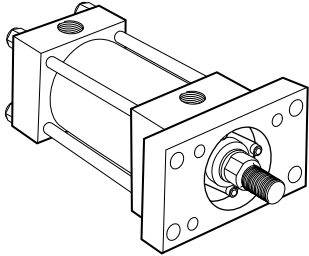

1" Bore Cylinder Only

1" Bore Cylinder Only
Head End

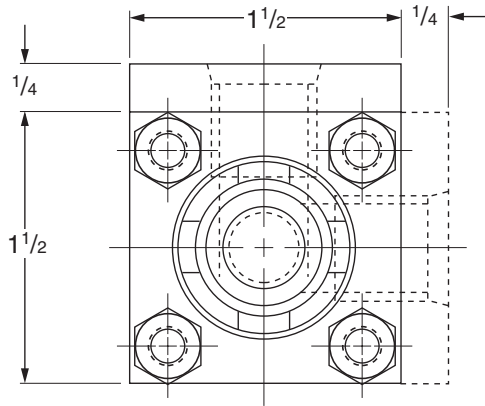

Rod End Dimensions — see table 2

Thread Style 2
Small Male

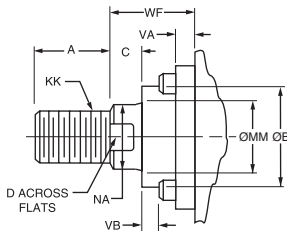

Thread Style 4
Short Female

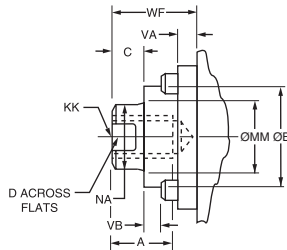

Thread Style 5
Intermediate Male

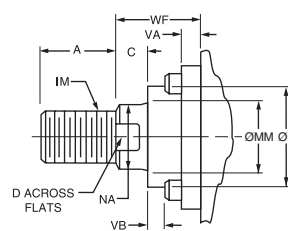

A high strength rod end stud is supplied on thread style 2 through 2" diameter rods and on thread style 5 through 1 3/8" diameter rods. Larger sizes or special rod ends are cut threads. Style 2 rod ends are recommended where the workpiece is secured against the rod shoulder. When the workpiece is not shouldered, style 2 rod ends

are recommended through 2" piston rod diameters and style 5 rod ends are recommended on larger diameters. Use style 4 for applications where female rod end threads are required. If rod end is not specified, style 2 will be supplied.

"Special" Thread Style X

Special thread, extension, rod eye, blank, etc., are also available.

To order, specify "Style X" and give desired dimensions for KK, A, W or WF. If otherwise special, furnish dimensioned sketch.

Miller AV Series Heavy-Duty Air Cylinders

Head Rectangular Flange Mount
1" to 6" Bore Sizes

Table 1—Envelope and Mounting Dimensions

Bore	E	EE NPTF	F	FB* (Bolt)	G	J	K	R	TF	UF	Add Stroke	
											LB	P
1	■	1/4	3/8	#10	1 1/2	1	3/16	1.08	2	2 1/2	3 7/8	2 1/8
1 1/2	2	3/8†	3/8	1/4	1 1/2	1	1/4	1.43	2 3/4	3 3/8	4	2 1/4
2	2 1/2	3/8†	3/8	5/16	1 1/2	1	5/16	1.84	3 3/8	4 1/8	4	2 1/4
2 1/2	3	3/8†	3/8	5/16	1 1/2	1	5/16	2.19	3 7/8	4 5/8	4 1/8	2 3/8
3 1/4	3 3/4	1/2	5/8	3/8	1 3/4	1 1/4	3/8	2.76	4 11/16	5 1/2	4 7/8	2 5/8
4	4 1/2	1/2	5/8	3/8	1 3/4	1 1/4	3/8	3.32	5 7/16	6 1/4	4 7/8	2 5/8
5	5 1/2	1/2	5/8	1/2	1 3/4	1 1/4	7/16	4.10	6 5/8	7 5/8	5 1/8	2 7/8
6	6 1/2	3/4	3/4	1/2	2	1 1/2	7/16	4.88	7 5/8	8 5/8	5 3/4	3 1/8

† On 1 1/2", 2" and 2 1/2" bore sizes, the head-end (only) pipe thread is not full depth on cylinders with maximum oversize rods. Minimum of three full threads available.

■ 1" bore head is 1 3/4" x 1 1/2".

*Mounting holes are 1/16" larger than bolt size listed.

Table 2—Rod Dimensions and Envelope Dimensions Affected by Rod Size

Bore	MM Rod Ø	Thread		Rod Extensions and Envelope Dimensions Affected By Rod Size										Add Stroke	
		Style 5 IM	Style 2 & 4 KK	A	B Ø +.000 -.002	C	D	NA	V	W	WF	Y	ZB		
														ZB	
1	1/2	7/16-20	5/16-24	5/8	.999	3/8	3/8	7/16	1/4	5/8	1	1 15/16	4 11/16		
	5/8	1/2-20	7/16-20	3/4	1.124	3/8	1/2	9/16	1/4	5/8	1	1 15/16	4 11/16		
1 1/2	5/8	1/2-20	7/16-20	3/4	1.124	3/8	1/2	9/16	1/4	5/8	1	1 15/16	4 7/8		
	1	7/8-14	3/4-16	1 1/8	1.499	1/2	7/8	15/16	1/2	1	1 3/8	2 5/16	5 1/4		
2	5/8	1/2-20	7/16-20	3/4	1.124	3/8	1/2	9/16	1/4	5/8	1	1 15/16	4 15/16		
	1 3/8	1 1/4-12	1-14	1 5/8	1.999	5/8	1 1/8	1 5/16	5/8	1 1/4	1 5/8	2 9/16	5 9/16		
2 1/2	1	7/8-14	3/4-16	1 1/8	1.499	1/2	7/8	15/16	1/2	1	1 3/8	2 5/16	5 5/16		
	5/8	1/2-20	7/16-20	3/4	1.124	3/8	1/2	9/16	1/4	5/8	1	1 15/16	5 1/16		
2 1/2	1 3/4	1 1/2-12	1 1/4-12	2	2.374	3/4	1 1/2	1 11/16	3/4	1 1/2	1 7/8	2 13/16	5 15/16		
	1	7/8-14	3/4-16	1 1/8	1.499	1/2	7/8	15/16	1/2	1	1 3/8	2 5/16	5 7/16		
3 1/4	1 3/8	1 1/4-12	1-14	1 5/8	1.999	5/8	1 1/8	1 5/16	5/8	1 1/4	1 5/8	2 9/16	5 11/16		
	1	7/8-14	3/4-16	1 1/8	1.499	1/2	7/8	15/16	1/4	3/4	1 3/8	2 7/16	6		
3 1/4	2	1 3/4-12	1 1/2-12	2 1/4	2.624	7/8	1 1/2	1 15/16	1/2	1 3/8	2	3 1/16	6 5/8		
	1 3/8	1 1/4-12	1-14	1 5/8	1.999	5/8	1 1/8	1 5/16	3/8	1	1 5/8	2 11/16	6 1/4		
3 1/4	1 3/4	1 1/2-12	1 1/4-12	2	2.374	3/4	1 1/2	1 11/16	1/2	1 1/4	1 7/8	2 15/16	6 1/2		
	1	7/8-14	3/4-16	1 1/8	1.499	1/2	7/8	15/16	1/4	3/4	1 3/8	2 7/16	6		
4	2 1/2	2 1/4-12	1 7/8-12	3	3.124	1	2 1/16	2 3/8	5/8	1 5/8	2 1/4	3 5/16	6 7/8		
	1 3/8	1 1/4-12	1-14	1 5/8	1.999	5/8	1 1/8	1 5/16	3/8	1	1 5/8	2 11/16	6 1/4		
4	1 3/4	1 1/2-12	1 1/4-12	2	2.374	3/4	1 1/2	1 11/16	1/2	1 1/4	1 7/8	2 15/16	6 1/2		
	2	1 3/4-12	1 1/2-12	2 1/4	2.624	7/8	1 1/2	1 15/16	1/2	1 3/8	2	3 1/16	6 5/8		
4	2 1/2	2 1/4-12	1 7/8-12	3	3.124	1	2 1/16	2 3/8	5/8	1 5/8	2 1/4	3 5/16	6 7/8		
	1	7/8-14	3/4-16	1 1/8	1.499	1/2	7/8	15/16	1/4	3/4	1 3/8	2 7/16	6 5/16		
5	3 1/2	3 1/4-12	2 1/2-12	3 1/2	4.249	1	3	3 3/8	5/8	1 5/8	2 1/4	3 5/16	7 3/16		
	1 3/8	1 1/4-12	1-14	1 5/8	1.999	5/8	1 1/8	1 5/16	3/8	1	1 5/8	2 11/16	6 9/16		
5	1 3/4	1 1/2-12	1 1/4-12	2	2.374	3/4	1 1/2	1 11/16	1/2	1 1/4	1 7/8	2 15/16	6 13/16		
	2	1 3/4-12	1 1/2-12	2 1/4	2.624	7/8	1 1/2	1 15/16	1/2	1 3/8	2	3 1/16	6 15/16		
5	2 1/2	2 1/4-12	1 7/8-12	3	3.124	1	2 1/16	2 3/8	5/8	1 5/8	2 1/4	3 5/16	7 3/16		
	3	2 3/4-12	2 1/4-12	3 1/2	3.749	1	2 5/8	2 7/8	5/8	1 5/8	2 1/4	3 5/16	7 3/16		
6	1 3/8	1 1/4-12	1-14	1 5/8	1.999	5/8	1 1/8	1 5/16	1/4	7/8	1 5/8	2 13/16	7 1/16		
	4	3 3/4-12	3-12	4	4.749	1	3 3/8	3 7/8	1/2	1 1/2	2 1/4	3 7/16	7 11/16		
6	1 3/4	1 1/2-12	1 1/4-12	2	2.374	3/4	1 1/2	1 11/16	3/8	1 1/8	1 7/8	3 1/16	7 5/16		
	2	1 3/4-12	1 1/2-12	2 1/4	2.624	7/8	1 1/2	1 15/16	3/8	1 1/4	2	3 3/16	7 7/16		
6	2 1/2	2 1/4-12	1 7/8-12	3	3.124	1	2 1/16	2 3/8	5/8	1 5/8	2 1/4	3 7/16	7 11/16		
	3	2 3/4-12	2 1/4-12	3 1/2	3.749	1	2 5/8	2 7/8	1/2	1 1/2	2 1/4	3 7/16	7 11/16		
6	3 1/2	3 1/4-12	2 1/2-12	3 1/2	4.249	1	3	3 3/8	1/2	1 1/2	2 1/4	3 7/16	7 11/16		

Miller AV Series Heavy-Duty Air Cylinders

Cap Rectangular Flange Mount
1" to 6" Bore Sizes

Cap Rectangular Flange Mount
Model 62
1" - 1 1/2" - 2" - 2 1/2" - 5" and 6" Bore
With Maximum Oversize Rods

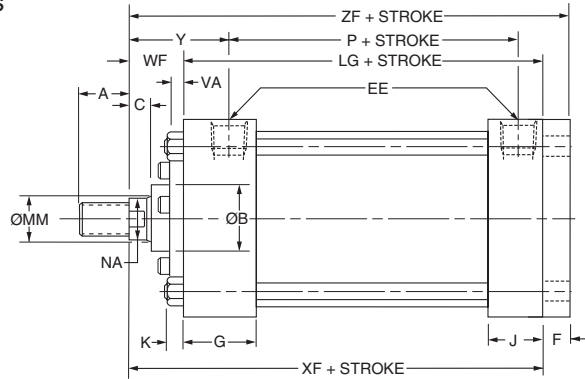
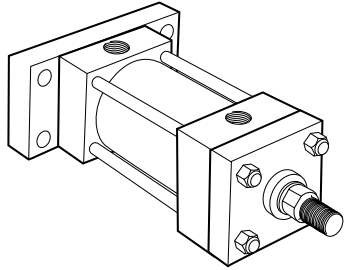

**Retainer Held
Bushing**

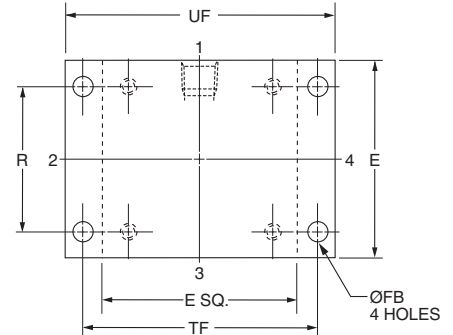

Before determining dimensions: See chart on page 3 for cylinder rod combinations that have removable bushings.

Cap Rectangular Flange Mount
Model 62
1 1/2" - 6" Bore

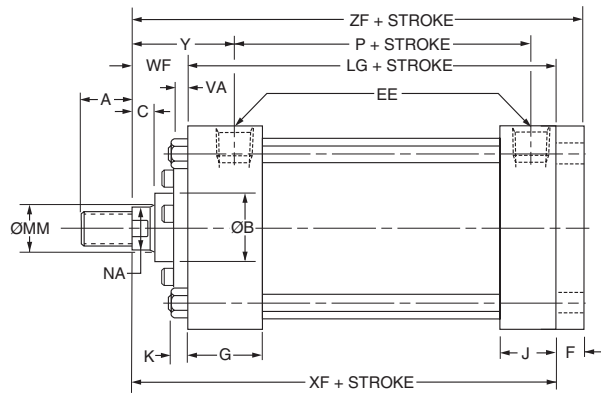
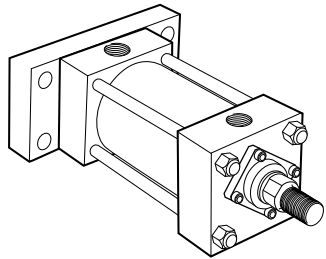

**Bolted
Bushing**

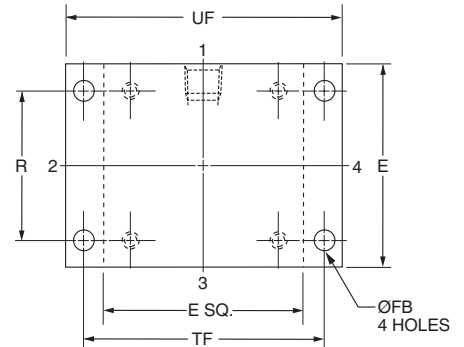

Rod End Dimensions — see table 2

Thread Style 2
Small Male

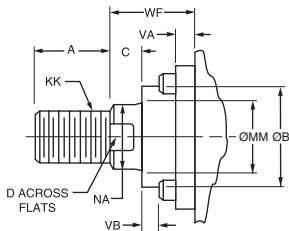

A high strength rod end stud is supplied on thread style 2 through 2" diameter rods and on thread style 5 through 1 3/8" diameter rods. Larger sizes or special rod ends are cut threads. Style 2 rod ends are recommended where the workpiece is secured against the rod shoulder. When the workpiece is not shouldered, style 2 rod ends

Thread Style 4
Short Female

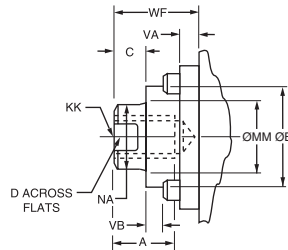

are recommended through 2" piston rod diameters and style 5 rod ends are recommended on larger diameters. Use style 4 for applications where female rod end threads are required. If rod end is not specified, style 2 will be supplied.

Thread Style 5
Intermediate Male

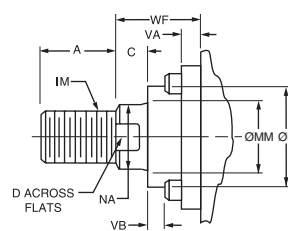

**"Special" Thread
Style X**

Special thread, extension, rod eye, blank, etc., are also available.

To order, specify "Style X" and give desired dimensions for KK, A, W or WF. If otherwise special, furnish dimensioned sketch.

Miller AV Series Heavy-Duty Air Cylinders

Cap Rectangular Flange Mount
1" to 6" Bore Sizes

Table 1—Envelope and Mounting Dimensions

Bore	E	EE NPTF	F	FB* (Bolt)	G	J	K	R	TF	UF	Add Stroke		
											LB	LG	P
1	■	1/4	3/8	#10	1 1/2	1	3/16	1.08	2	2 1/2	3 7/8	—	2 1/8
1 1/2	2	3/8†	3/8	1/4	1 1/2	1	1/4	1.43	2 3/4	3 3/8	4	3 5/8	2 1/4
2	2 1/2	3/8†	3/8	5/16	1 1/2	1	5/16	1.84	3 3/8	4 1/8	4	3 5/8	2 1/4
2 1/2	3	3/8†	3/8	5/16	1 1/2	1	5/16	2.19	3 7/8	4 5/8	4 1/8	3 3/4	2 3/8
3 1/4	3 3/4	1/2	5/8	3/8	1 3/4	1 1/4	3/8	2.76	4 11/16	5 1/2	—	4 1/4	2 5/8
4	4 1/2	1/2	5/8	3/8	1 3/4	1 1/4	3/8	3.32	5 7/16	6 1/4	—	4 1/4	2 5/8
5	5 1/2	1/2	5/8	1/2	1 3/4	1 1/4	7/16	4.10	6 5/8	7 5/8	5 1/8	4 1/2	2 7/8
6	6 1/2	3/4	3/4	1/2	2	1 1/2	7/16	4.88	7 5/8	8 5/8	5 3/4	5	3 1/8

† On 1 1/2", 2" and 2 1/2" bore sizes, the head-end (only) pipe thread is not full depth on cylinders with maximum oversize rods. Minimum of three full threads available.

■ 1" bore head is 1 3/4" x 1 1/2".

*Mounting holes are 1/16" larger than bolt size listed.

Table 2—Rod Dimensions and Envelope Dimensions Affected by Rod Size

Bore	MM Rod Ø	Thread		Rod Extensions and Envelope Dimensions Affected By Rod Size											Add Stroke	
		Style 5 IM	Style 2 & 4 KK	A	B Ø +0.002 -0.002	C	D	NA	V	VA	VB	W	WF	Y	XF	ZF
		1	1/2	7/16-20	5/16-24	5/8	.999	3/8	3/8	7/16	1/4	—	—	5/8	—	1 15/16
	5/8	1/2-20	7/16-20	3/4	1.124	3/8	1/2	9/16	1/4	—	—	5/8	—	1 15/16	4 1/2	4 7/8
1 1/2	5/8	1/2-20	7/16-20	3/4	1.124	3/8	1/2	9/16	—	1/4	3/16	—	1	1 15/16	4 5/8	5
	1	7/8-14	3/4-16	1 1/8	1.499	1/2	7/8	1 5/16	1/2	—	—	1	—	2 5/16	5	5 3/8
2	5/8	1/2-20	7/16-20	3/4	1.124	3/8	1/2	9/16	—	1/4	3/16	—	1	1 15/16	4 5/8	5
	1 3/8	1 1/4-12	1-14	1 5/8	1.999	5/8	1 1/8	1 5/16	5/8	—	—	1 1/4	—	2 9/16	5 1/4	5 5/8
	1	7/8-14	3/4-16	1 1/8	1.499	1/2	7/8	1 5/16	—	1/4	3/8	—	1 3/8	2 5/16	5	5 3/8
2 1/2	5/8	1/2-20	7/16-20	3/4	1.124	3/8	1/2	9/16	—	1/4	3/16	—	1	1 15/16	4 3/4	5 1/8
	1 3/4	1 1/2-12	1 1/4-12	2	2.374	3/4	1 1/2	1 11/16	3/4	—	—	1 1/2	—	2 13/16	5 5/8	6
	1	7/8-14	3/4-16	1 1/8	1.499	1/2	7/8	1 5/16	—	1/4	3/8	—	1 3/8	2 5/16	5 1/8	5 1/2
	1 3/8	1 1/4-12	1-14	1 5/8	1.999	5/8	1 1/8	1 5/16	5/8	—	—	1 1/4	—	2 9/16	5 3/8	5 3/4
3 1/4	1	7/8-14	3/4-16	1 1/8	1.499	1/2	7/8	1 5/16	—	1/4	3/8	—	1 3/8	2 7/16	5 5/8	6 1/4
	2	1 3/4-12	1 1/2-12	2 1/4	2.624	7/8	1 11/16	1 15/16	—	1/4	9/16	—	2	3 1/16	6 1/4	6 7/8
	1 3/8	1 1/4-12	1-14	1 5/8	1.999	5/8	1 1/8	1 5/16	—	1/4	1/2	—	1 5/8	2 11/16	5 7/8	6 1/2
	1 3/4	1 1/2-12	1 1/4-12	2	2.374	3/4	1 1/2	1 11/16	—	1/4	9/16	—	1 7/8	2 15/16	6 1/8	6 3/4
4	1	7/8-14	3/4-16	1 1/8	1.499	1/2	7/8	1 5/16	—	1/4	3/8	—	1 3/8	2 7/16	5 5/8	6 1/4
	2 1/2	2 1/4-12	1 7/8-12	3	3.124	1	2 1/16	2 3/8	—	1/4	1 1/16	—	2 1/4	3 5/16	6 1/2	7 1/8
	1 3/8	1 1/4-12	1-14	1 5/8	1.999	5/8	1 1/8	1 5/16	—	1/4	1/2	—	1 5/8	2 11/16	5 7/8	6 1/2
	1 3/4	1 1/2-12	1 1/4-12	2	2.374	3/4	1 1/2	1 11/16	—	1/4	9/16	—	1 7/8	2 15/16	6 1/8	6 3/4
	2	1 3/4-12	1 1/2-12	2 1/4	2.624	7/8	1 11/16	1 15/16	—	1/4	9/16	—	2	3 1/16	6 1/4	6 7/8
5	1	7/8-14	3/4-16	1 1/8	1.499	1/2	7/8	1 5/16	—	1/4	3/8	—	1 3/8	2 7/16	5 7/8	6 1/2
	3 1/2	3 1/4-12	2 1/2-12	3 1/2	4.249	1	3	3 3/8	5/8	—	—	1 5/8	—	3 5/16	6 3/4	7 3/8
	1 3/8	1 1/4-12	1-14	1 5/8	1.999	5/8	1 1/8	1 5/16	—	1/4	1/2	—	1 5/8	2 11/16	6 1/8	6 3/4
	1 3/4	1 1/2-12	1 1/4-12	2	2.374	3/4	1 1/2	1 11/16	—	1/4	9/16	—	1 7/8	2 15/16	6 3/8	7
	2	1 3/4-12	1 1/2-12	2 1/4	2.624	7/8	1 11/16	1 15/16	—	1/4	9/16	—	2	3 1/16	6 1/2	7 1/8
	2 1/2	2 1/4-12	1 7/8-12	3	3.124	1	2 1/16	2 3/8	—	1/4	1 1/16	—	2 1/4	3 5/16	6 3/4	7 3/8
	3	2 3/4-12	2 1/4-12	3 1/2	3.749	1	2 5/8	2 7/8	5/8	—	—	1 5/8	—	3 5/16	6 3/4	7 3/8
6	1 3/8	1 1/4-12	1-14	1 5/8	1.999	5/8	1 1/8	1 5/16	—	1/4	7/16	—	1 5/8	2 13/16	6 5/8	7 3/8
	4	3 3/4-12	3-12	4	4.749	1	3 3/8	3 7/8	1/2	—	—	1 1/2	—	3 7/16	7 1/4	8
	1 3/4	1 1/2-12	1 1/4-12	2	2.374	3/4	1 1/2	1 11/16	—	1/4	9/16	—	1 7/8	3 1/16	6 7/8	7 5/8
	2	1 3/4-12	1 1/2-12	2 1/4	2.624	7/8	1 11/16	1 15/16	—	1/4	9/16	—	2	3 1/16	7	7 3/4
	2 1/2	2 1/4-12	1 7/8-12	3	3.124	1	2 1/16	2 3/8	—	1/4	1 1/16	—	2 1/4	3 7/16	7 1/4	8
	3	2 3/4-12	2 1/4-12	3 1/2	3.749	1	2 5/8	2 7/8	1/2	—	—	1 1/2	—	3 7/16	7 1/4	8
	3 1/2	3 1/4-12	2 1/2-12	3 1/2	4.249	1	3	3 3/8	1/2	—	—	1 1/2	—	3 7/16	7 1/4	8

Miller AV Series Heavy-Duty Air Cylinders

Head Square Flange Mount
Cap Square Flange Mount
1" to 6" Bore Sizes

Head Square Flange Mount Model 65 1" - 6" Bore

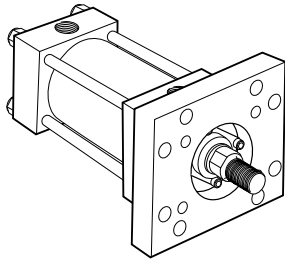

Bolted Bushing

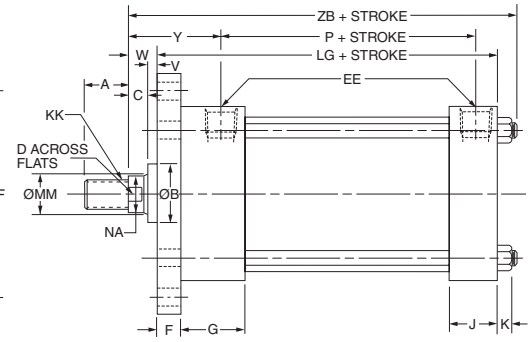
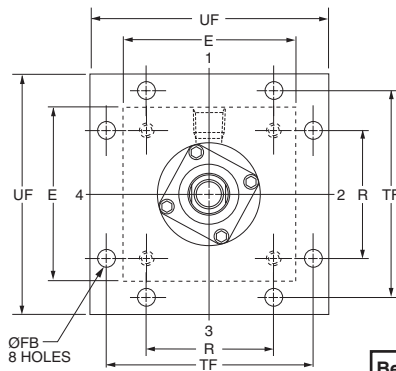

Before determining dimensions: See chart on page 3 for cylinder rod combinations that have removable bushings.

Cap Square Flange Mount Model 66 1" - 1 1/2" - 2" - 2 1/2" - 5" and 6" Bore With Maximum Oversize Rods

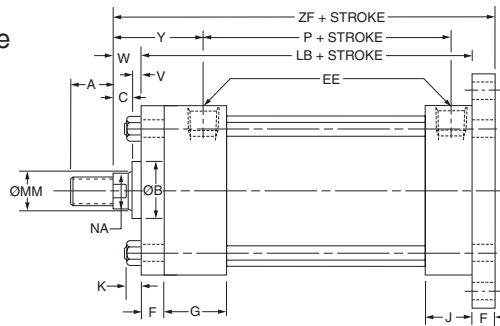
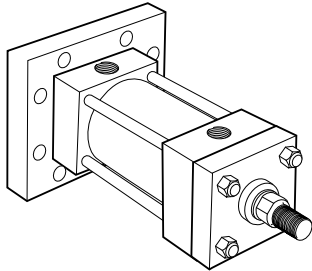

Retainer Held Bushing

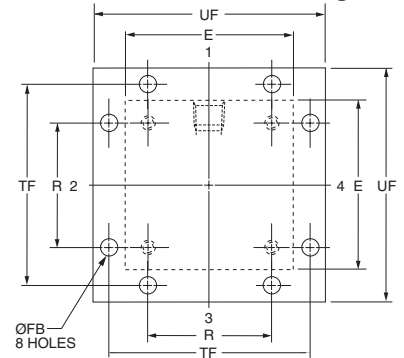

Cap Square Flange Mount Model 66 1 1/2" - 6" Bore

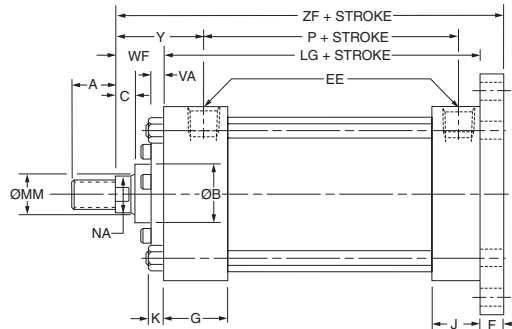
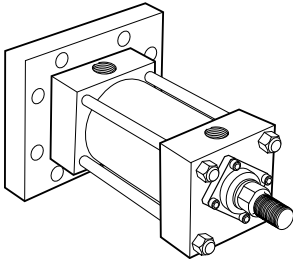

Bolted Bushing

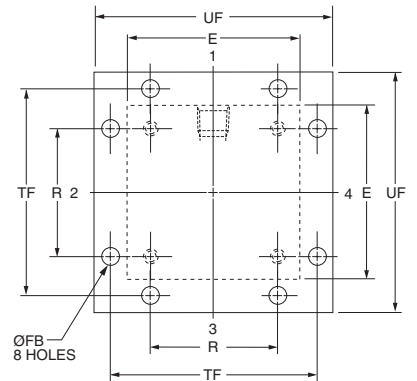

Rod End Dimensions — see table 2

Thread Style 2 Small Male

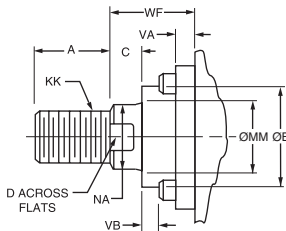

Thread Style 4 Short Female

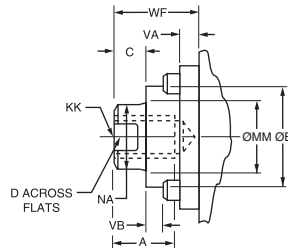

Thread Style 5 Intermediate Male

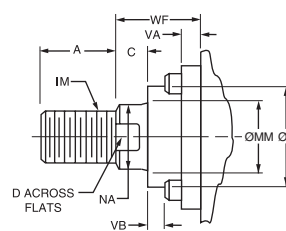

"Special" Thread Style X

Special thread, extension, rod eye, blank, etc., are also available.

To order, specify "Style X" and give desired dimensions for KK, A, W or WF. If otherwise special, furnish dimensioned sketch.

A high strength rod end stud is supplied on thread style 2 through 2" diameter rods and on thread style 5 through 1 3/8" diameter rods. Larger sizes or special rod ends are cut threads. Style 2 rod ends are recommended where the workpiece is secured against the rod shoulder. When the workpiece is not shouldered, style 2 rod ends

are recommended through 2" piston rod diameters and style 5 rod ends are recommended on larger diameters. Use style 4 for applications where female rod end threads are required. If rod end is not specified, style 2 will be supplied.

Miller AV Series Heavy-Duty Air Cylinders

Head Square Flange Mount
Cap Square Flange Mount
1" to 6" Bore Sizes

Table 1—Envelope and Mounting Dimensions

Bore	E	EE NPTF	F	FB* (Bolt)	G	J	K	R	TF	UF	Add Stroke		
											LB	LG	P
1	■	1/4	3/8	#10	1 1/2	1	3/16	1.08	2	2 1/2	3 7/8	—	2 1/8
1 1/2	2	3/8†	3/8	1/4	1 1/2	1	1/4	1.43	2 3/4	3 3/8	4	3 5/8	2 1/4
2	2 1/2	3/8†	3/8	5/16	1 1/2	1	5/16	1.84	3 3/8	4 1/8	4	3 5/8	2 1/4
2 1/2	3	3/8†	3/8	5/16	1 1/2	1	5/16	2.19	3 7/8	4 5/8	4 1/8	3 3/4	2 3/8
3 1/4	3 3/4	1/2	5/8	3/8	1 3/4	1 1/4	3/8	2.76	4 11/16	5 1/2	4 7/8	4 1/4	2 5/8
4	4 1/2	1/2	5/8	3/8	1 3/4	1 1/4	3/8	3.32	5 7/16	6 1/4	4 7/8	4 1/4	2 5/8
5	5 1/2	1/2	5/8	1/2	1 3/4	1 1/4	7/16	4.10	6 5/8	7 5/8	5 1/8	4 1/2	2 7/8
6	6 1/2	3/4	3/4	1/2	2	1 1/2	7/16	4.88	7 5/8	8 5/8	5 3/4	5	3 1/8

† On 1 1/2", 2" and 2 1/2" bore sizes, the head-end (only) pipe thread is not full depth on cylinders with maximum oversize rods. Minimum of three full threads available.

■ 1" bore head is 1 3/4" x 1 1/2".

*Mounting holes are 1/16" larger than bolt size listed.

Table 2—Rod End Dimensions and Envelope Dimensions Affected By Rod Size

Bore	MM Rod Ø	Thread		Rod Extensions and Envelope Dimensions Affected By Rod Size											Add Stroke	
		Style 5 IM	Style 2 & 4 KK	A	B Ø +.000 -.002	C	D	NA	V	VA	VB	W	WF	Y	ZB	ZF
1	1/2	7/16-20	5/16-24	5/8	.999	3/8	3/8	7/16	1/4	—	—	5/8	—	1 5/16	4 11/16	4 7/8
	5/8	1/2-20	7/16-20	3/4	1.124	3/8	1/2	9/16	1/4	—	—	5/8	—	1 5/16	4 11/16	4 7/8
1 1/2	5/8	1/2-20	7/16-20	3/4	1.124	3/8	1/2	9/16	1/4*	1/4	3/16	1/4	1	1 5/16	4 7/8	5
	1	7/8-14	3/4-16	1 1/8	1.499	1/2	7/8	1 5/16	1/2	—	—	1	—	2 5/16	5 1/4	5 3/8
2	5/8	1/2-20	7/16-20	3/4	1.124	3/8	1/2	9/16	1/4*	1/4	3/16	5/8	1	1 5/16	4 5/16	5
	1 3/8	1 1/4-12	1-14	1 5/8	1.999	5/8	1 1/8	1 5/16	5/8	—	—	1 1/4	—	2 9/16	5 9/16	5 5/8
2 1/2	1	7/8-14	3/4-16	1 1/8	1.499	1/2	7/8	1 5/16	1/2*	1/4	3/8	1	1 3/8	2 5/16	5 5/16	5 3/8
	5/8	1/2-20	7/16-20	3/4	1.124	3/8	1/2	9/16	1/4*	1/4	3/16	5/8	1	1 5/16	5 1/16	5 1/8
3 1/4	1 3/4	1 1/2-12	1 1/4-12	2	2.374	3/4	1 1/2	1 11/16	3/4	—	—	1 1/2	—	2 13/16	5 5/16	6
	1	7/8-14	3/4-16	1 1/8	1.499	1/2	7/8	1 5/16	1/2*	1/4	3/8	1	1 3/8	2 5/16	5 7/16	5 1/2
4	1 3/8	1 1/4-12	1-14	1 5/8	1.999	5/8	1 1/8	1 5/16	5/8	—	—	1 1/4	—	2 9/16	5 11/16	5 3/4
	1	7/8-14	3/4-16	1 1/8	1.499	1/2	7/8	1 5/16	1/4*	1/4	3/8	3/4	1 3/8	2 7/16	6	6 1/4
5	2 1/2	2 1/4-12	1 7/8-12	3	3.124	1	2 1/16	2 9/8	5/8*	1/4	1 1/16	1 5/8	2 1/4	3 5/16	6 7/8	7 1/8
	1 3/8	1 1/4-12	1-14	1 5/8	1.999	5/8	1 1/8	1 5/16	3/8*	1/4	1/2	1	1 5/8	2 11/16	6 3/16	6 3/4
6	1 3/4	1 1/2-12	1 1/4-12	2	2.374	3/4	1 1/2	1 11/16	1/2*	1/4	9/16	1 1/4	1 7/8	2 15/16	6 1/2	6 3/4
	2	1 3/4-12	1 1/2-12	2 1/4	2.624	7/8	1 11/16	1 15/16	1/2*	1/4	9/16	1 3/8	2	3 1/16	6 5/8	6 7/8
7	1	7/8-14	3/4-16	1 1/8	1.499	1/2	7/8	1 5/16	1/4*	1/4	3/8	3/4	1 3/8	2 7/16	6 5/16	6 1/2
	3 1/2	3 1/4-12	2 1/2-12	3 1/2	4.249	1	3	3 3/8	5/8	—	—	1 5/8	—	3 5/16	7 3/16	7 3/8
8	1 3/8	1 1/4-12	1-14	1 5/8	1.999	5/8	1 1/8	1 5/16	1/4	1/4	1/4	1	1 5/8	2 11/16	6 9/16	6 3/4
	1 3/4	1 1/2-12	1 1/4-12	2	2.374	3/4	1 1/2	1 11/16	3/8*	1/4	9/16	1 1/4	1 7/8	2 15/16	6 13/16	7
9	2	1 3/4-12	1 1/2-12	2 1/4	2.624	7/8	1 11/16	1 15/16	1/2*	1/4	9/16	1 3/8	2	3 1/16	6 15/16	7 1/8
	2 1/2	2 1/4-12	1 7/8-12	3	3.124	1	2 1/16	2 9/8	5/8*	1/4	1 1/16	1 5/8	2 1/4	3 5/16	7 3/16	7 3/8
10	3	2 3/4-12	2 1/4-12	3 1/2	3.749	1	2 5/8	2 7/8	5/8	—	—	1 5/8	—	3 5/16	7 3/16	7 3/8
	1 3/8	1 1/4-12	1-14	1 5/8	1.999	5/8	1 1/8	1 5/16	1/4	1/4	7/16	1 5/8	2 13/16	6 7/16	7 3/8	
11	4	3 3/4-12	3-12	4	4.749	1	3 3/8	3 7/8	3/8	—	—	1 1/2	—	3 7/16	7 11/16	8
	1 3/4	1 1/2-12	1 1/4-12	2	2.374	3/4	1 1/2	1 11/16	3/8*	1/4	9/16	1 1/4	1 7/8	2 15/16	6 7/16	7 5/8
12	2	1 3/4-12	1 1/2-12	2 1/4	2.624	7/8	1 11/16	1 15/16	1/2*	1/4	9/16	1 1/4	2	3 1/16	6 7/16	7 3/4
	2 1/2	2 1/4-12	1 7/8-12	3	3.124	1	2 1/16	2 9/8	1/2*	1/4	1 1/16	1 1/2	2 1/4	3 7/16	7 11/16	8
13	3	2 3/4-12	2 1/4-12	3 1/2	3.749	1	2 5/8	2 7/8	1/2	—	—	1 1/2	—	3 7/16	7 11/16	8
	3 1/2	3 1/4-12	2 1/2-12	3 1/2	4.249	1	3	3 3/8	1/2	—	—	1 1/2	—	3 7/16	7 11/16	8

* For all Model 65 and Model 66 mounts with maximum oversized rods.

Miller AV Series Heavy-Duty Air Cylinders

Tie Rods Extended Mountings
1" to 6" Bore Sizes

Tie Rods Extended Both Ends Mount

Model 51

1" - 1 1/2" - 2" - 2 1/2" - 5" and 6" Bore

With Maximum Oversize Rods

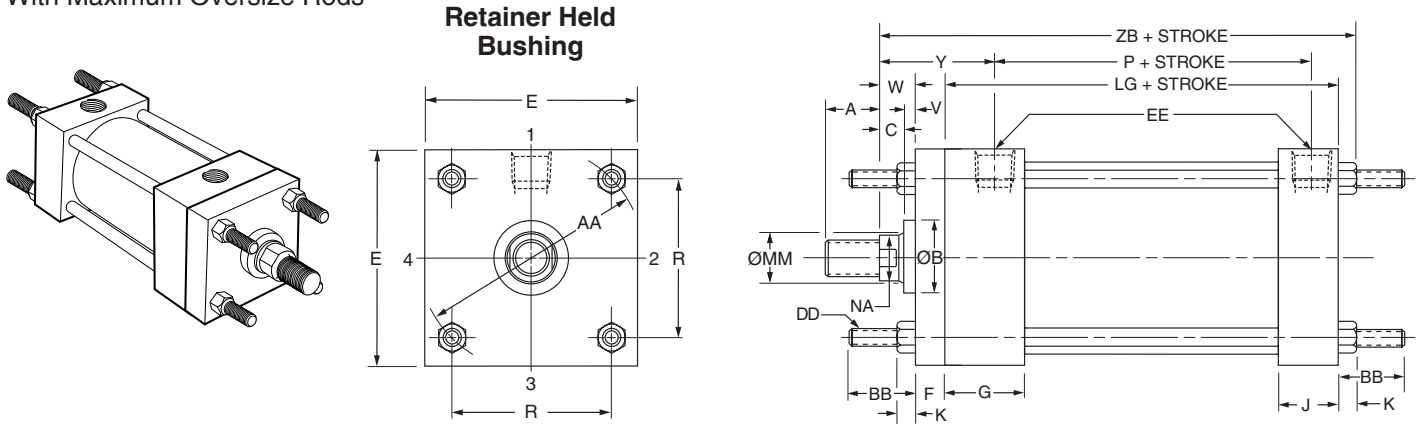

Tie Rods can be extended: Both Ends — Model 51; Cap End — Model 52; Head End — Model 53. All Tie Rod Models can be dimensioned from Model 51 drawings shown.

Before determining dimensions: See chart on page 3 for cylinder rod combinations that have removable bushings.

Tie Rods Extended Both Ends Mount

Model 51

1 1/2" - 6" Bore

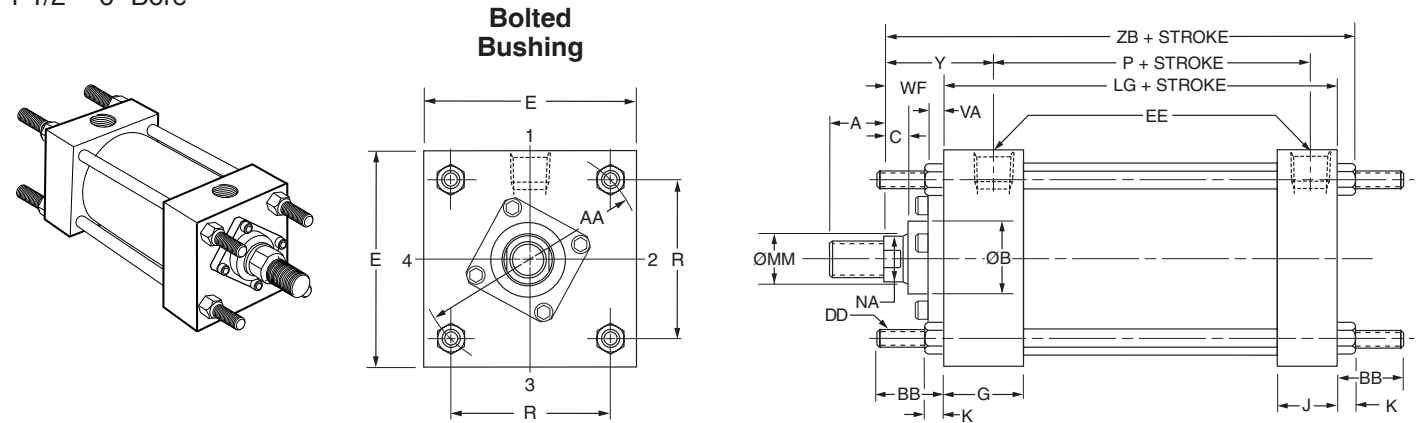

Rod End Dimensions — see table 2

Thread Style 2

Small Male

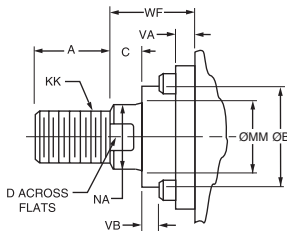

A high strength rod end stud is supplied on thread style 2 through 2" diameter rods and on thread style 5 through 1 3/8" diameter rods. Larger sizes or special rod ends are cut threads. Style 2 rod ends are recommended where the workpiece is secured against the rod shoulder. When the workpiece is not shouldered, style 2 rod ends

Thread Style 4

Short Female

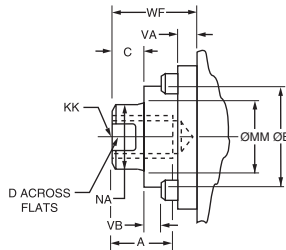

are recommended through 2" piston rod diameters and style 5 rod ends are recommended on larger diameters. Use style 4 for applications where female rod end threads are required. If rod end is not specified, style 2 will be supplied.

Thread Style 5

Intermediate Male

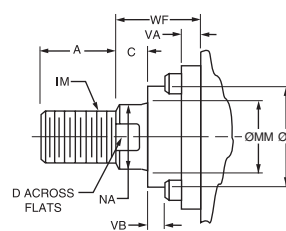

"Special" Thread Style X

Special thread, extension, rod eye, blank, etc., are also available.

To order, specify "Style X" and give desired dimensions for KK, A, W or WF. If otherwise special, furnish dimensioned sketch.

Miller AV Series Heavy-Duty Air Cylinders

Tie Rods Extended Mountings
1" to 6" Bore Sizes

Table 1—Envelope and Mounting Dimensions

Bore	AA	BB	DD	E	EE NPTF	F	G	J	K	R	Add Stroke	
											LG	P
1	1.53	3/4	10-24	■	1/4	3/8	1 1/2	1	3/16	1.08	3 1/2	2 1/8
1 1/2	2.02	1	1/4-28	2	3/8†	3/8	1 1/2	1	1/4	1.43	3 5/8	2 1/4
2	2.6	1 1/8	5/16-24	2 1/2	3/8†	3/8	1 1/2	1	5/16	1.84	3 5/8	2 1/4
2 1/2	3.1	1 1/8	5/16-24	3	3/8†	3/8	1 1/2	1	5/16	2.19	3 3/4	2 3/8
3 1/4	3.9	1 3/8	3/8-24	3 3/4	1/2	—	1 3/4	1 1/4	3/8	2.76	4 1/4	2 5/8
4	4.7	1 3/8	3/8-24	4 1/2	1/2	—	1 3/4	1 1/4	3/8	3.32	4 1/4	2 5/8
5	5.8	1 13/16	1/2-20	5 1/2	1/2	5/8	1 3/4	1 1/4	7/16	4.10	4 1/2	2 7/8
6	6.9	1 13/16	1/2-20	6 1/2	3/4	3/4	2	1 1/2	7/16	4.88	5	3 1/8

† On 1 1/2", 2" and 2 1/2" bore sizes, the head-end (only) pipe thread is not full depth on cylinders with maximum oversize rods. Minimum of three full threads available.

■ 1" bore head is 1 3/4" x 1 1/2".

Table 2—Rod End Dimensions and Envelope Dimensions Affected By Rod Size

Bore	MM Rod Ø	Thread		Rod Extensions and Envelope Dimensions Affected By Rod Size													Add Stroke
		Style 5 IM	Style 2 & 4 KK	A	B Ø +.000 - .002	BF	C	D	NA	V	VA	VB	W	WF	Y		
		ZB															
1	1/2	7/16-20	5/16-24	5/8	.999	—	3/8	3/8	7/16	1/4	—	—	5/8	—	1 5/16	4 11/16	
	5/8	1/2-20	7/16-20	3/4	1.124	—	3/8	1/2	9/16	1/4	—	—	5/8	—	1 5/16	4 11/16	
1 1/2	5/8	1/2-20	7/16-20	3/4	1.124	1.968	3/8	1/2	9/16	—	1/4	3/16	—	1	1 5/16	4 7/8	
	1	7/8-14	3/4-16	1 1/8	1.499	—	1/2	7/8	1 5/16	1/2	—	—	1	—	2 5/16	5 1/4	
2	5/8	1/2-20	7/16-20	3/4	1.124	1.968	3/8	1/2	9/16	—	1/4	3/16	—	1	1 5/16	4 5/16	
	1 3/8	1 1/4-12	1-14	1 5/8	1.999	—	5/8	1 1/8	1 5/16	5/8	—	—	1 1/4	—	2 9/16	5 9/16	
2 1/2	1	7/8-14	3/4-16	1 1/8	1.499	2.468	1/2	7/8	1 5/16	—	1/4	3/8	—	1 3/8	2 5/16	5 5/16	
	1 3/8	1 1/4-12	1-14	1 5/8	1.999	2.968	5/8	1 1/8	1 5/16	5/8	—	—	1 1/4	—	2 9/16	5 1/16	
3 1/4	1	7/8-14	3/4-16	1 1/8	1.499	2.968	1/2	7/8	1 5/16	—	1/4	3/8	—	1 3/8	2 7/16	6	
	2	1 3/4-12	1 1/2-12	2 1/4	2.624	3.735	7/8	1 11/16	1 5/16	—	1/4	9/16	—	2	3 1/16	6 5/8	
4	1 3/8	1 1/4-12	1-14	1 5/8	1.999	2.968	5/8	1 1/8	1 5/16	—	1/4	1/2	—	1 5/8	2 11/16	6 1/4	
	1 3/4	1 1/2-12	1 1/4-12	2	2.374	3.735	3/4	1 1/2	1 11/16	—	1/4	9/16	—	1 7/8	2 5/16	6 1/2	
5	2	1 3/4-12	1 1/2-12	2 1/4	2.624	3.735	7/8	1 11/16	1 5/16	—	1/4	9/16	—	2	3 1/16	6 5/8	
	2 1/2	2 1/4-12	1 7/8-12	3	3.124	5.000	1	2 1/16	2 9/8	—	1/4	1 1/16	—	2 1/4	3 5/16	7 3/16	
6	3	2 3/4-12	2 1/4-12	3 1/2	3.749	5.000	1	2 5/8	2 7/8	5/8	—	—	1 5/8	—	3 5/16	7 3/16	
	3 1/2	3 1/4-12	2 1/2-12	3 1/2	4.249	5.562	1	3	3 3/8	5/8	—	—	1 5/8	—	3 5/16	7 3/16	
7	1 3/8	1 1/4-12	1-14	1 5/8	1.999	2.968	5/8	1 1/8	1 5/16	—	1/4	7/16	—	1 5/8	2 13/16	7 1/16	
	1 3/4	1 1/2-12	1 1/4-12	2	2.374	3.625	3/4	1 1/2	1 11/16	—	1/4	9/16	—	1 7/8	3 1/16	7 5/16	
8	2	1 3/4-12	1 1/2-12	2 1/4	2.624	4.312	7/8	1 11/16	1 5/16	—	1/4	9/16	—	2	3 3/16	7 7/16	
	2 1/2	2 1/4-12	1 7/8-12	3	3.124	4.312	1	2 1/16	2 9/8	—	1/4	1 1/16	—	2 1/4	3 7/16	7 11/16	
9	3	2 3/4-12	2 1/4-12	3 1/2	3.749	5.562	1	2 5/8	2 7/8	1/2	—	—	1 1/2	—	3 7/16	7 11/16	
	3 1/2	3 1/4-12	2 1/2-12	3 1/2	4.249	5.562	1	3	3 3/8	1/2	—	—	1 1/2	—	3 7/16	7 11/16	

Miller AV Series Heavy-Duty Air Cylinders

Head Trunnion Mount
1" to 6" Bore Sizes

Head Trunnion Mount

Model 81

1" - 1 1/2" - 2" - 2 1/2" - 5" and 6" Bore

With Maximum Oversize Rods

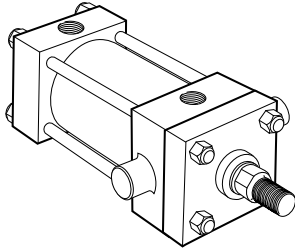

Retainer Held Bushing

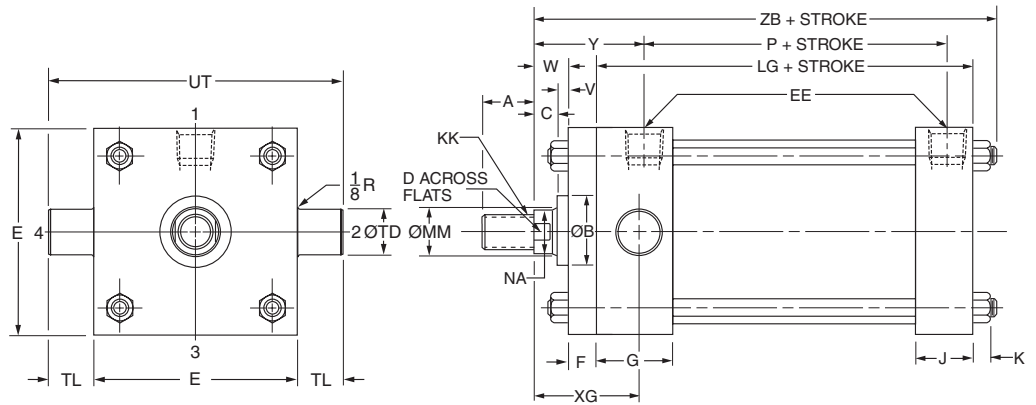

Before determining dimensions: See chart on page 3 for cylinder rod combinations that have removable bushings.

Head Trunnion Mount

Model 81

1 1/2" - 6" Bore

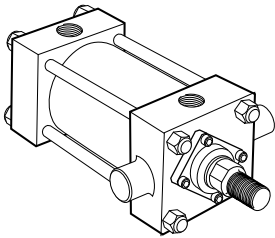

Bolted Bushing

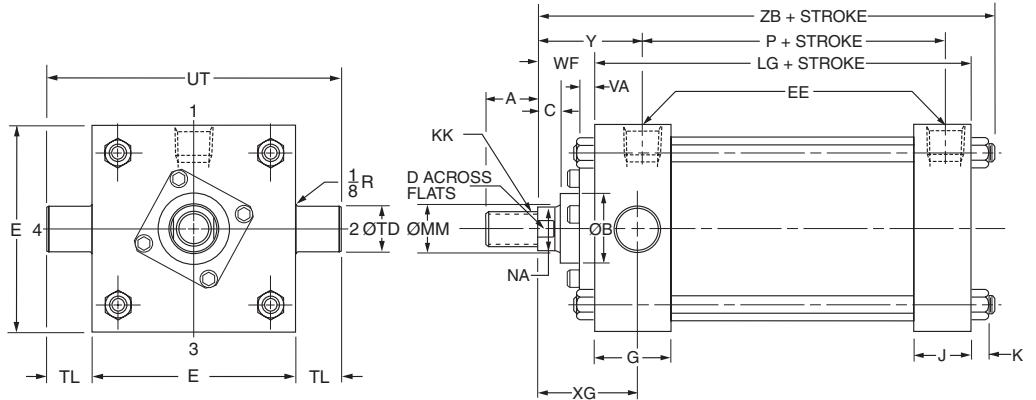

Rod End Dimensions — see table 2

Thread Style 2

Small Male

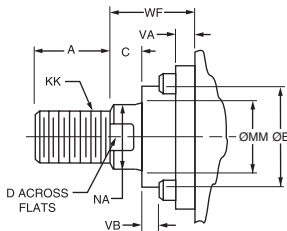

A high strength rod end stud is supplied on thread style 2 through 2" diameter rods and on thread style 5 through 1 3/8" diameter rods. Larger sizes or special rod ends are cut threads. Style 2 rod ends are recommended where the workpiece is secured against the rod shoulder. When the workpiece is not shouldered, style 2 rod ends

Thread Style 4

Short Female

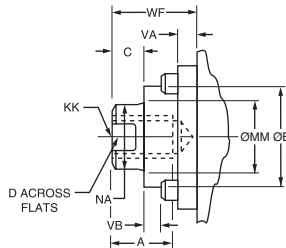

are recommended through 2" piston rod diameters and style 5 rod ends are recommended on larger diameters. Use style 4 for applications where female rod end threads are required. If rod end is not specified, style 2 will be supplied.

Thread Style 5

Intermediate Male

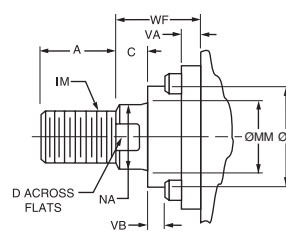

"Special" Thread Style X

Special thread, extension, rod eye, blank, etc., are also available.

To order, specify "Style X" and give desired dimensions for KK, A, W or WF. If otherwise special, furnish dimensioned sketch.

Miller AV Series Heavy-Duty Air Cylinders

Head Trunnion Mount
1" to 6" Bore Sizes

Table 1—Envelope and Mounting Dimensions

Bore	E	EE NPTF	F	G	J	K	TD Ø +0.000 -0.001	TL	UT	Add Stroke	
										LG	P
1	■	1/4	3/8	1 1/2	1	3/16	.750	3/4	3	3 1/2	2 1/8
1 1/2	2	3/8†	3/8	1 1/2	1	1/4	1.000	1	4	3 5/8	2 1/4
2	2 1/2	3/8†	3/8	1 1/2	1	5/16	1.000	1	4 1/2	3 5/8	2 1/4
2 1/2	3	3/8†	3/8	1 1/2	1	5/16	1.000	1	5	3 3/4	2 3/8
3 1/4	3 3/4	1/2	—	1 3/4	1 1/4	3/8	1.000	1	5 3/4	4 1/4	2 5/8
4	4 1/2	1/2	—	1 3/4	1 1/4	3/8	1.000	1	6 1/2	4 1/4	2 5/8
5	5 1/2	1/2	5/8	1 3/4	1 1/4	7/16	1.000	1	7 1/2	4 1/2	2 7/8
6	6 1/2	3/4	3/4	2	1 1/2	7/16	1.375	1 3/8	9 1/4	5	3 1/8

† On 1 1/2", 2" and 2 1/2" bore sizes, the head-end (only) pipe thread is not full depth on cylinders with maximum oversize rods. Minimum of three full threads available.

■ 1" bore head is 1 3/4" x 1 1/2".

Table 2—Rod End Dimensions and Envelope Dimensions Affected By Rod Size

Bore	MM Rod Ø	Thread		Rod Extensions and Envelope Dimensions Affected By Rod Size													Add Stroke	
		Style 5 IM	Style 2 & 4 KK	A	B Ø +0.000 -0.002	C	D	NA	V	VA	VB	W	WF	XG	Y	ZB		
																	Add Stroke	
1	1/2	7/16-20	5/16-24	5/8	.999	3/8	3/8	7/16	1/4	—	—	5/8	—	1 3/4	1 15/16	4 11/16		
	5/8	1/2-20	7/16-20	3/4	1.124	3/8	1/2	9/16	1/4	—	—	5/8	—	1 3/4	1 15/16	4 11/16		
1 1/2	5/8	1/2-20	7/16-20	3/4	1.124	3/8	1/2	9/16	—	1/4	3/16	—	1	1 3/4	1 15/16	4 7/8		
	1	7/8-14	3/4-16	1 1/8	1.499	1/2	7/8	15/16	1/2	—	—	1	—	2 1/8	2 5/16	5 1/4		
2	5/8	1/2-20	7/16-20	3/4	1.124	3/8	1/2	9/16	—	1/4	3/16	—	1	1 3/4	1 15/16	4 5/16		
	1 3/8	1 1/4-12	1-14	1 5/8	1.999	5/8	1 1/8	1 5/16	5/8	—	—	1 1/4	—	2 3/8	2 9/16	5 9/16		
2 1/2	1	7/8-14	3/4-16	1 1/8	1.499	1/2	7/8	15/16	—	1/4	3/8	—	1 3/8	2 1/8	2 5/16	5 5/16		
	5/8	1/2-20	7/16-20	3/4	1.124	3/8	1/2	9/16	—	1/4	3/16	—	1	1 3/4	1 15/16	5 1/16		
3 1/4	1 3/4	1 1/2-12	1 1/4-12	2	2.374	3/4	1 1/2	1 11/16	3/4	—	—	1 1/2	—	2 5/8	2 13/16	5 5/16		
	1	7/8-14	3/4-16	1 1/8	1.499	1/2	7/8	15/16	—	1/4	3/8	—	1 3/8	2 1/4	2 7/16	6		
4	2	1 3/4-12	1 1/2-12	2 1/4	2.624	7/8	1 11/16	1 15/16	—	1/4	9/16	—	2	2 7/8	3 1/16	6 5/8		
	1 3/8	1 1/4-12	1-14	1 5/8	1.999	5/8	1 1/8	1 5/16	—	1/4	1/2	—	1 5/8	2 1/2	2 11/16	6 1/4		
5	1 3/4	1 1/2-12	1 1/4-12	2	2.374	3/4	1 1/2	1 11/16	—	1/4	9/16	—	1 7/8	2 3/4	2 15/16	6 13/16		
	1	7/8-14	3/4-16	1 1/8	1.499	1/2	7/8	15/16	—	1/4	3/8	—	1 3/8	2 1/4	2 7/16	6 5/16		
6	3 1/2	3 1/4-12	2 1/2-12	3 1/2	4.249	1	3	3 3/8	5/8	—	—	1 5/8	—	3 1/8	3 5/16	7 3/16		
	1 3/8	1 1/4-12	1-14	1 5/8	1.999	5/8	1 1/8	1 5/16	—	1/4	1/2	—	1 5/8	2 1/2	2 11/16	6 9/16		
7	1 3/4	1 1/2-12	1 1/4-12	2	2.374	3/4	1 1/2	1 11/16	—	1/4	9/16	—	1 7/8	2 3/4	2 15/16	6 13/16		
	2	1 3/4-12	1 1/2-12	2 1/4	2.624	7/8	1 11/16	1 15/16	—	1/4	9/16	—	2	2 7/8	3 1/16	6 15/16		
8	2 1/2	2 1/4-12	1 7/8-12	3	3.124	1	2 1/16	2 3/8	—	1/4	1 1/16	—	2 1/4	3 1/8	3 5/16	7 3/16		
	3	2 3/4-12	2 1/4-12	3 1/2	3.749	1	2 5/8	2 7/8	5/8	—	—	1 5/8	—	3 3/8	3 5/16	7 3/16		
9	1 3/8	1 1/4-12	1-14	1 5/8	1.999	5/8	1 1/8	1 5/16	—	1/4	7/16	—	1 5/8	2 5/8	2 13/16	7 1/16		
	4	3 3/4-12	3-12	4	4.749	1	3 3/8	3 7/8	1/2	—	—	1 1/2	—	3 1/4	3 7/16	7 11/16		
10	1 3/4	1 1/2-12	1 1/4-12	2	2.374	3/4	1 1/2	1 11/16	—	1/4	9/16	—	1 7/8	2 7/8	3 1/16	7 5/16		
	2	1 3/4-12	1 1/2-12	2 1/4	2.624	7/8	1 11/16	1 15/16	—	1/4	9/16	—	2	3	3 3/16	7 7/16		
11	2 1/2	2 1/4-12	1 7/8-12	3	3.124	1	2 1/16	2 3/8	—	1/4	1 1/16	—	2 1/4	3 1/4	3 7/16	7 11/16		
	3	2 3/4-12	2 1/4-12	3 1/2	3.749	1	2 5/8	2 7/8	1/2	—	—	1 1/2	—	3 1/4	3 7/16	7 11/16		
12	3 1/2	3 1/4-12	2 1/2-12	3 1/2	4.249	1	3	3 3/8	1/2	—	—	1 1/2	—	3 1/4	3 7/16	7 11/16		

Miller AV Series Heavy-Duty Air Cylinders

Cap Trunnion Mount
1" to 6" Bore Sizes

Cap Trunnion Mount

Model 82

1" - 1 1/2" - 2" - 2 1/2" - 5" and 6" Bore

With Maximum Oversize Rods

Retainer Held Bushing

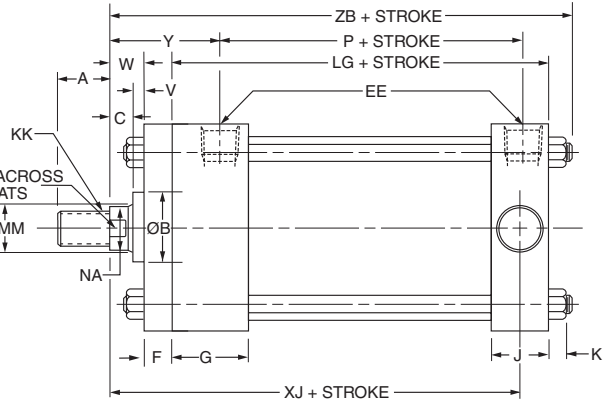
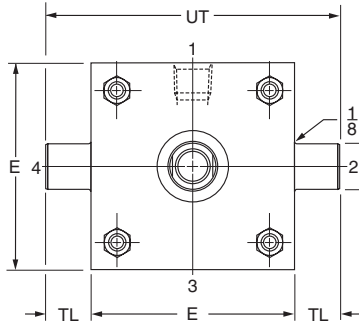
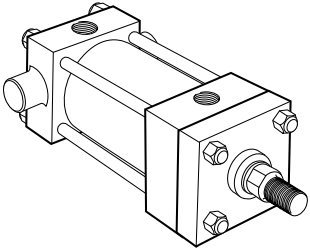

Before determining dimensions: See chart on page 3 for cylinder rod combinations that have removable bushings.

Cap Trunnion Mount

Model 82

1 1/2" - 6" Bore

Bolted Bushing

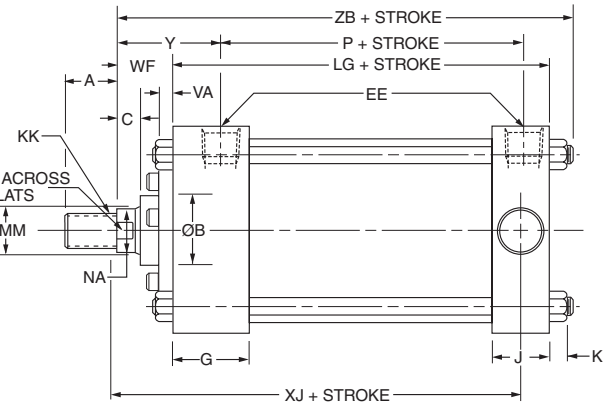
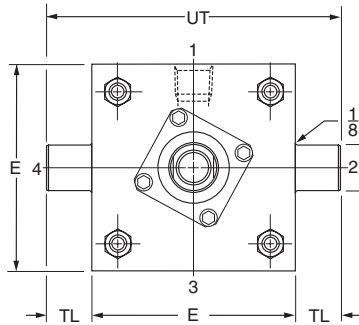
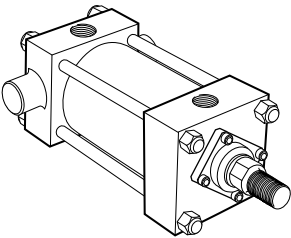

Rod End Dimensions — see table 2

Thread Style 2

Small Male

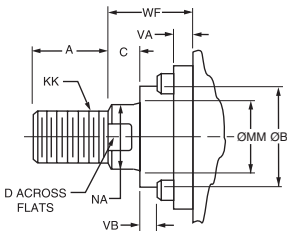

A high strength rod end stud is supplied on thread style 2 through 2" diameter rods and on thread style 5 through 1 3/8" diameter rods. Larger sizes or special rod ends are cut threads. Style 2 rod ends are recommended where the workpiece is secured against the rod shoulder. When the workpiece is not shouldered, style 2 rod ends

Thread Style 4

Short Female

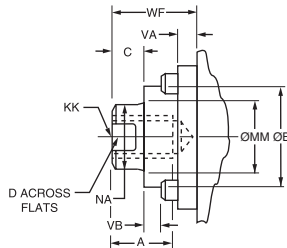

are recommended through 2" piston rod diameters and style 5 rod ends are recommended on larger diameters. Use style 4 for applications where female rod end threads are required. If rod end is not specified, style 2 will be supplied.

Thread Style 5

Intermediate Male

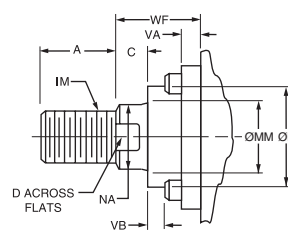

"Special" Thread Style X

Special thread, extension, rod eye, blank, etc., are also available.

To order, specify "Style X" and give desired dimensions for KK, A, W or WF. If otherwise special, furnish dimensioned sketch.

Miller AV Series Heavy-Duty Air Cylinders

Cap Trunnion Mount
1" to 6" Bore Sizes

Table 1—Envelope and Mounting Dimensions

Bore	E	EE NPTF	F	G	J	K	TD Ø +0.000 -0.001	TL	UT	Add Stroke	
										LG	P
1	■	1/4	3/8	1 1/2	1	3/16	.750	3/4	3	3 1/2	2 1/8
1 1/2	2	3/8†	3/8	1 1/2	1	1/4	1.000	1	4	3 5/8	2 1/4
2	2 1/2	3/8†	3/8	1 1/2	1	5/16	1.000	1	4 1/2	3 5/8	2 1/4
2 1/2	3	3/8†	3/8	1 1/2	1	5/16	1.000	1	5	3 3/4	2 3/8
3 1/4	3 3/4	1/2	—	1 3/4	1 1/4	3/8	1.000	1	5 3/4	4 1/4	2 5/8
4	4 1/2	1/2	—	1 3/4	1 1/4	3/8	1.000	1	6 1/2	4 1/4	2 5/8
5	5 1/2	1/2	5/8	1 3/4	1 1/4	7/16	1.000	1	7 1/2	4 1/2	2 7/8
6	6 1/2	3/4	3/4	2	1 1/2	7/16	1.375	1 3/8	9 1/4	5	3 1/8

† On 1 1/2", 2" and 2 1/2" bore sizes, the head-end (only) pipe thread is not full depth on cylinders with maximum oversize rods. Minimum of three full threads available.

■ 1" bore head is 1 3/4" x 1 1/2".

Table 2—Rod End Dimensions and Envelope Dimensions Affected By Rod Size

Bore	MM Rod Ø	Thread		Rod Extensions and Envelope Dimensions Affected By Rod Size												Add Stroke	
		Style 5 IM	Style 2 & 4 KK	A	B Ø +0.000 -0.002	C	D	NA	V	VA	VB	W	WF	Y	XJ	ZB	
1	1/2	7/16-20	5/16-24	5/8	.999	3/8	3/8	7/16	1/4	—	—	5/8	—	1 5/16	4	4 11/16	
	5/8	1/2-20	7/16-20	3/4	1.124	3/8	1/2	9/16	1/4	—	—	5/8	—	1 5/16	4	4 11/16	
1 1/2	5/8	1/2-20	7/16-20	3/4	1.124	3/8	1/2	9/16	—	1/4	3/16	—	1	1 5/16	4 1/8	4 7/8	
	1	7/8-14	3/4-16	1 1/8	1.499	1/2	7/8	1 5/16	1/2	—	—	1	—	2 5/16	4 1/2	5 1/4	
2	5/8	1/2-20	7/16-20	3/4	1.124	3/8	1/2	9/16	—	1/4	3/16	—	1	1 5/16	4 1/8	4 5/16	
	1 3/8	1 1/4-12	1-14	1 5/8	1.999	5/8	1 1/8	1 5/16	5/8	—	—	1 1/4	—	2 9/16	4 3/4	5 9/16	
2 1/2	1	7/8-14	3/4-16	1 1/8	1.499	1/2	7/8	1 5/16	—	1/4	3/8	—	1 3/8	2 5/16	4 1/2	5 5/16	
	5/8	1/2-20	7/16-20	3/4	1.124	3/8	1/2	9/16	—	1/4	3/16	—	1	1 5/16	4 1/4	5 1/16	
3 1/4	1 3/4	1 1/2-12	1 1/4-12	2	2.374	3/4	1 1/2	1 11/16	3/4	—	—	1 1/2	—	2 13/16	5 1/8	5 5/16	
	1	7/8-14	3/4-16	1 1/8	1.499	1/2	7/8	1 5/16	—	1/4	3/8	—	1 3/8	2 5/16	4 5/8	5 7/16	
4	1 3/8	1 1/4-12	1-14	1 5/8	1.999	5/8	1 1/8	1 5/16	5/8	—	—	1 1/4	1 5/8	2 9/16	4 7/8	5 11/16	
	1	7/8-14	3/4-16	1 1/8	1.499	1/2	7/8	1 5/16	—	1/4	3/8	—	1 3/8	2 7/16	5	6	
5	2 1/2	2 1/4-12	1 7/8-12	3	3.124	1	2 1/16	2 9/8	—	1/4	1 1/16	—	2 1/4	3 5/16	5 7/8	6 7/8	
	1 3/8	1 1/4-12	1-14	1 5/8	1.999	5/8	1 1/8	1 5/16	—	1/4	1/2	—	1 5/8	2 11/16	5 1/2	6 3/16	
6	1 3/4	1 1/2-12	1 1/4-12	2	2.374	3/4	1 1/2	1 11/16	—	1/4	9/16	—	1 7/8	2 5/16	5 3/4	6 13/16	
	2	1 3/4-12	1 1/2-12	2 1/4	2.624	7/8	1 11/16	1 5/16	—	1/4	9/16	—	2	3 1/16	5 7/8	6 5/16	
7	2 1/2	2 1/4-12	1 7/8-12	3	3.124	1	2 1/16	2 9/8	—	1/4	1 1/16	—	2 1/4	3 5/16	6 3/8	7 3/16	
	3	2 3/4-12	2 1/4-12	3 1/2	3.749	1	2 5/8	2 7/8	5/8	—	—	1 5/8	—	3 5/16	6 1/8	7 3/16	
8	1 3/8	1 1/4-12	1-14	1 5/8	1.999	5/8	1 1/8	1 5/16	—	1/4	7/16	—	1 5/8	2 13/16	5 7/8	7 1/16	
	4	3 3/4-12	3-12	4	4.749	1	3 3/8	3 7/8	1/2	—	—	1 1/2	—	3 7/16	6 1/2	7 11/16	
9	1 3/4	1 1/2-12	1 1/4-12	2	2.374	3/4	1 1/2	1 11/16	—	1/4	9/16	—	1 7/8	3 1/16	6 1/8	7 5/16	
	2	1 3/4-12	1 1/2-12	2 1/4	2.624	7/8	1 11/16	1 5/16	—	1/4	9/16	—	2	3 3/16	6 1/4	7 7/16	
10	2 1/2	2 1/4-12	1 7/8-12	3	3.124	1	2 1/16	2 9/8	—	1/4	1 1/16	—	2 1/4	3 7/16	6 1/2	7 11/16	
	3	2 3/4-12	2 1/4-12	3 1/2	3.749	1	2 5/8	2 7/8	1/2	—	—	1 1/2	—	3 7/16	6 1/2	7 11/16	
11	3 1/2	3 1/4-12	2 1/2-12	3 1/2	4.249	1	3	3 3/8	1/2	—	—	1 1/2	—	3 7/16	6 1/2	7 11/16	

Miller AV Series Heavy-Duty Air Cylinders

Intermediate Trunnion Mount
1 1/2" to 6" Bore Sizes

Intermediate Trunnion Mount
Model 89
1 1/2" - 2" - 2 1/2" - 5" and 6" Bore
With Maximum Oversize Rods

**Retainer Held
Bushing**

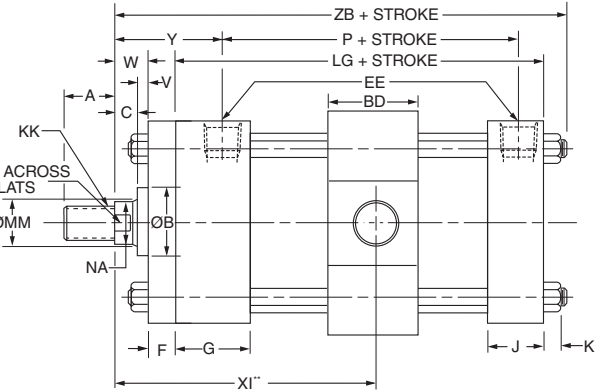
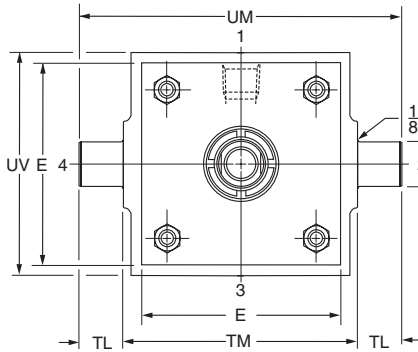
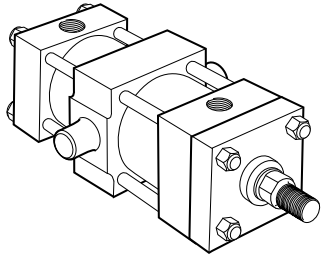

**Dimension "XI" to be specified by customer.

Before determining dimensions: See chart on page 3 for cylinder rod combinations that have removable bushings.

Intermediate Trunnion Mount
Model 89
1 1/2" - 6" Bore

Bolted Bushing

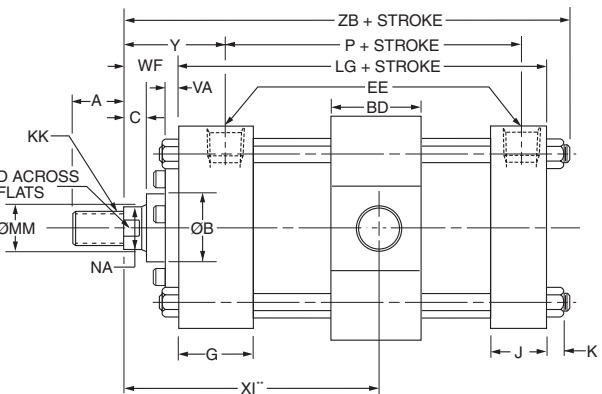
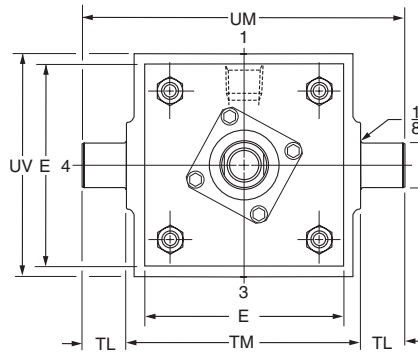
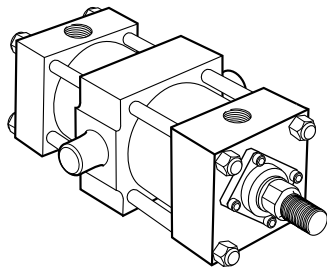

**Dimension "XI" to be specified by customer.

Rod End Dimensions — see table 2

Thread Style 2
Small Male

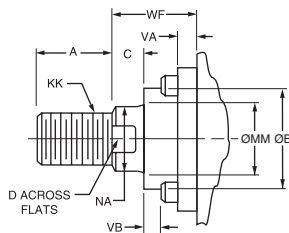

Thread Style 4
Short Female

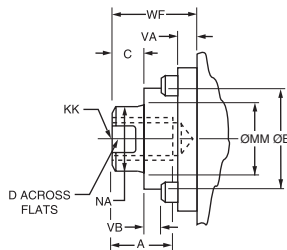

Thread Style 5
Intermediate Male

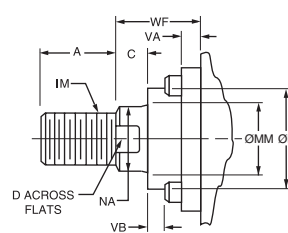

"Special" Thread Style X

Special thread, extension, rod eye, blank, etc., are also available.

To order, specify "Style X" and give desired dimensions for KK, A, W or WF. If otherwise special, furnish dimensioned sketch.

A high strength rod end stud is supplied on thread style 2 through 2" diameter rods and on thread style 5 through 1 3/8" diameter rods. Larger sizes or special rod ends are cut threads. Style 2 rod ends are recommended where the workpiece is secured against the rod shoulder. When the workpiece is not shouldered, style 2 rod ends

are recommended through 2" piston rod diameters and style 5 rod ends are recommended on larger diameters. Use style 4 for applications where female rod end threads are required. If rod end is not specified, style 2 will be supplied.

Miller AV Series Heavy-Duty Air Cylinders

Intermediate Trunnion Mount
1 1/2" to 6" Bore Sizes

Table 1—Envelope and Mounting Dimensions

Bore	BD	E	EE NPTF	F	G	J	K	TD Ø +0.000 -0.001	TL	TM	UM	UV	Minimum Stroke	Add Stroke	
														LG	P
1 1/2	1 1/4	2	3/8†	3/8	1 1/2	1	1/4	1.000	1	2 1/2	4 1/2	2 1/2	1/4	3 5/8	2 1/4
2	1 1/2	2 1/2	3/8†	3/8	1 1/2	1	5/16	1.000	1	3	5	3	1/2	3 5/8	2 1/4
2 1/2	1 1/2	3	3/8†	3/8	1 1/2	1	5/16	1.000	1	3 1/2	5 1/2	3 1/2	3/8	3 3/4	2 3/8
3 1/4	2	3 3/4	1/2	5/8	1 3/4	1 1/4	3/8	1.000	1	4 1/2	6 1/2	4 1/4	7/8	4 1/4	2 5/8
4	2	4 1/2	1/2	—	1 3/4	1 1/4	3/8	1.000	1	5 1/4	7 1/4	5	7/8	4 1/4	2 5/8
5	2	5 1/2	1/2	—	1 3/4	1 1/4	7/16	1.000	1	6 1/4	8 1/4	6	5/8	4 1/2	2 7/8
6	2 1/2	6 1/2	3/4	3/4	2	1 1/2	7/16	1.375	1 3/8	7 5/8	10 3/8	7	1 1/8	5	3 1/8

† On 1 1/2", 2" and 2 1/2" bore sizes, the head-end (only) pipe thread is not full depth on cylinders with maximum oversize rods. Minimum of three full threads available.

Table 2—Rod End Dimensions and Envelope Dimensions Affected By Rod Size

Bore	MM Rod Ø	Thread		Rod Extensions and Envelope Dimensions Affected By Rod Size														Add Stroke ZB
		Style 5 IM	Style 2 & 4 KK	LL	A	B Ø +0.000 -0.002	C	D	NA	V	VA	VB	W	WF	Min. XI**	Y		
1 1/2	5/8	1/2-20	7/16-20	1/2-20	3/4	1.124	3/8	1/2	9/16	—	1/4	3/16	—	1	3 3/16	1 15/16	4 7/8	
	1	7/8-14	3/4-16	7/8-14	1 1/8	1.499	1/2	7/8	15/16	1/2	—	—	1	—	3 9/16	2 5/16	5 1/4	
2	5/8	1/2-20	7/16-20	1/2-20	3/4	1.124	3/8	1/2	9/16	—	1/4	3/16	—	1	3 5/16	1 15/16	4 5/16	
	1 3/8	1 1/4-12	1-14	1 1/4-12	1 5/8	1.999	5/8	1 1/8	1 5/16	5/8	—	—	1 1/4	—	3 15/16	2 9/16	5 9/16	
2 1/2	1	7/8-14	3/4-16	7/8-14	1 1/8	1.499	1/2	7/8	15/16	—	1/4	3/8	—	1 3/8	3 11/16	2 5/16	5 7/16	
	1 3/4	1 1/2-12	1 1/4-12	1 1/2-12	2	2.374	3/4	1 1/2	1 11/16	3/4	—	—	1 1/2	—	4 3/16	2 13/16	5 15/16	
3 1/4	1	7/8-14	3/4-16	7/8-14	1 1/8	1.499	1/2	7/8	15/16	—	1/4	3/8	—	1 3/8	3 11/16	2 5/16	5 7/16	
	1 3/8	1 1/4-12	1-14	1 1/4-12	1 5/8	1.999	5/8	1 1/8	1 5/16	5/8	—	—	1 1/4	—	3 15/16	2 9/16	5 11/16	
4	1	7/8-14	3/4-16	7/8-14	1 1/8	1.499	1/2	7/8	15/16	—	1/4	3/8	—	1 3/8	3 11/16	2 5/16	5 7/16	
	2 1/2	2 1/4-12	1 7/8-12	2 1/4-12	3	3.124	1	2 1/16	2 3/8	—	1/4	1 1/16	—	2 1/4	5 1/16	3 5/16	6 7/8	
5	1 3/8	1 1/4-12	1-14	1 1/4-12	1 5/8	1.999	5/8	1 1/8	1 5/16	—	1/4	1/2	—	1 5/8	4 7/16	2 11/16	6 1/4	
	1 3/4	1 1/2-12	1 1/4-12	1 1/2-12	2	2.374	3/4	1 1/2	1 11/16	—	1/4	9/16	—	1 7/8	4 11/16	2 15/16	6 1/2	
6	1	7/8-14	3/4-16	7/8-14	1 1/8	1.499	1/2	7/8	15/16	—	1/4	3/8	—	1 3/8	4 3/16	2 7/16	6	
	3 1/2	3 1/4-12	2 1/2-12	3 1/4-12	3 1/2	4.249	1	3	3 3/8	5/8	—	—	1 5/8	—	5 1/16	3 5/16	7 3/16	
7	1 3/8	1 1/4-12	1-14	1 1/4-12	1 5/8	1.999	5/8	1 1/8	1 5/16	—	1/4	1/2	—	1 5/8	4 7/16	2 11/16	6 9/16	
	1 3/4	1 1/2-12	1 1/4-12	1 1/2-12	2	2.374	3/4	1 1/2	1 11/16	—	1/4	9/16	—	1 7/8	4 11/16	2 15/16	6 13/16	
8	2	1 3/4-12	1 1/2-12	1 3/4-12	2 1/4	2.624	7/8	1 11/16	1 5/16	—	1/4	9/16	—	2	4 13/16	3 1/16	6 5/8	
	2 1/2	2 1/4-12	1 7/8-12	2 1/4-12	3	3.124	1	2 1/16	2 3/8	—	1/4	1 1/16	—	2 1/4	5 1/16	3 5/16	7 3/16	
9	1 3/4	1 1/2-12	1 1/4-12	1 1/2-12	2	2.374	3/4	1 1/2	1 11/16	—	1/4	9/16	—	1 7/8	4 11/16	2 15/16	6 1/2	
	2	1 3/4-12	1 1/2-12	1 3/4-12	2 1/4	2.624	7/8	1 11/16	1 5/16	—	1/4	9/16	—	2	4 13/16	3 1/16	6 5/8	
10	2 1/2	2 1/4-12	1 7/8-12	2 1/4-12	3	3.124	1	2 1/16	2 3/8	—	1/4	1 1/16	—	2 1/4	5 1/16	3 5/16	7 3/16	
	3	2 3/4-12	2 1/4-12	2 3/4-12	3 1/2	3.749	1	2 5/8	2 7/8	5/8	—	—	1 5/8	—	5 1/16	3 5/16	7 3/16	
11	1 3/8	1 1/4-12	1-14	1 1/4-12	1 5/8	1.999	5/8	1 1/8	1 5/16	—	1/4	7/16	—	1 5/8	4 15/16	2 13/16	7 1/16	
	4	3 3/4-12	3-12	3 3/4-12	4	4.749	1	3 3/8	3 7/8	1/2	—	—	1 1/2	—	5 9/16	3 7/16	7 11/16	
12	1 3/4	1 1/2-12	1 1/4-12	1 1/2-12	2	2.374	3/4	1 1/2	1 11/16	—	1/4	9/16	—	1 7/8	5 3/16	3 1/16	7 5/16	
	2	1 3/4-12	1 1/2-12	1 3/4-12	2 1/4	2.624	7/8	1 11/16	1 5/16	—	1/4	9/16	—	2	5 5/16	3 3/16	7 7/16	
13	2 1/2	2 1/4-12	1 7/8-12	2 1/4-12	3	3.124	1	2 1/16	2 3/8	—	1/4	1 1/16	—	2 1/4	5 9/16	3 7/16	7 11/16	
	3	2 3/4-12	2 1/4-12	2 3/4-12	3 1/2	3.749	1	2 5/8	2 7/8	1/2	—	—	1 1/2	—	5 9/16	3 7/16	7 11/16	
14	1 3/8	1 1/4-12	1-14	1 1/4-12	1 5/8	1.999	5/8	1 1/8	1 5/16	—	1/4	7/16	—	1 5/8	4 15/16	2 13/16	7 1/16	
	4	3 3/4-12	3-12	3 3/4-12	4	4.749	1	3 3/8	3 7/8	1/2	—	—	1 1/2	—	5 9/16	3 7/16	7 11/16	

** Dimension XI to be specified by customer.

Miller AV Series Heavy-Duty Air Cylinders

Cap Fixed Clevis Mount
1" to 6" Bore Sizes

Cap Fixed Clevis Mount

Model 84

1" - 1 1/2" - 2" - 2 1/2" - 5" and 6" Bore
With Maximum Oversize Rods

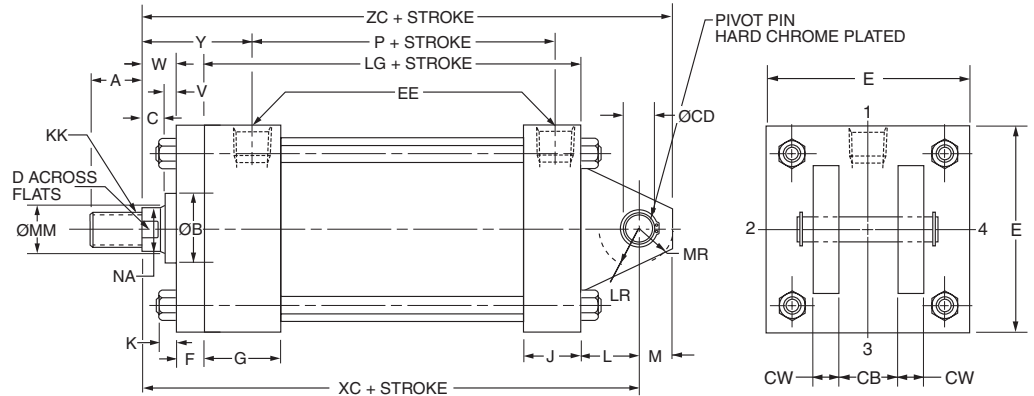
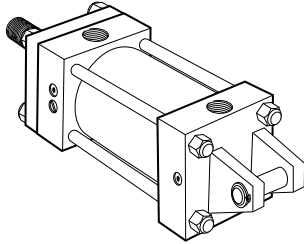

Note: Cap tie rod nuts not on 1 1/2", 2", 2 1/2" and 3 1/4" bores.

Before determining dimensions: See chart on page 3 for cylinder rod combinations that have removable bushings.

Cap Fixed Clevis Mount

Model 84

1 1/2" - 6" Bore

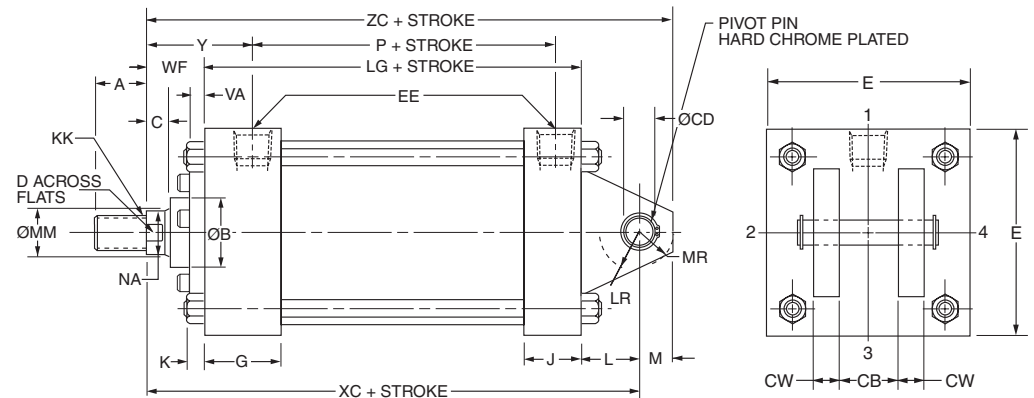
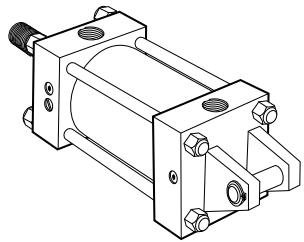

Note: Cap tie rod nuts not on 1 1/2", 2", 2 1/2" and 3 1/4" bores.

Rod End Dimensions — see table 2

Thread Style 2

Small Male

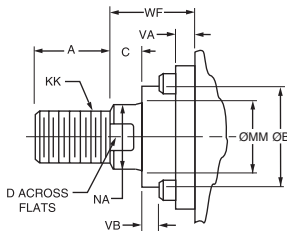

A high strength rod end stud is supplied on thread style 2 through 2" diameter rods and on thread style 5 through 1 3/8" diameter rods. Larger sizes or special rod ends are cut threads. Style 2 rod ends are recommended where the workpiece is secured against the rod shoulder. When the workpiece is not shouldered, style 2 rod ends

Thread Style 4

Short Female

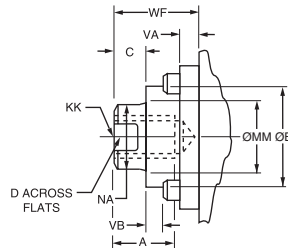

are recommended through 2" piston rod diameters and style 5 rod ends are recommended on larger diameters. Use style 4 for applications where female rod end threads are required. If rod end is not specified, style 2 will be supplied.

Thread Style 5

Intermediate Male

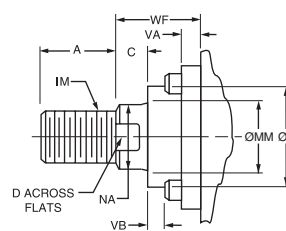

"Special" Thread Style X

Special thread, extension, rod eye, blank, etc., are also available.

To order, specify "Style X" and give desired dimensions for KK, A, W or WF. If otherwise special, furnish dimensioned sketch.

Miller AV Series Heavy-Duty Air Cylinders

Cap Fixed Clevis Mount
1" to 6" Bore Sizes

Table 1—Envelope and Mounting Dimensions

Bore	CB	CD Ø ⁺ +.000 -.002	CW	E	EE NPTF	F	G	J	K	L	LR	M	MR	Add Stroke	
														LG	P
1	*	.441*	*	■	1/4	3/8	1 1/2	1	3/16	1/2*	1/2*	7/16*	1/2*	3 1/2*	2 1/8
1 1/2	3/4	.501	1/2	2	3/8†	3/8	1 1/2	1	1/4	3/4	3/4	1/2	5/8	3 5/8	2 1/4
2	3/4	.501	1/2	2 1/2	3/8†	3/8	1 1/2	1	5/16	3/4	3/4	1/2	5/8	3 3/8	2 1/4
2 1/2	3/4	.501	1/2	3	3/8†	3/8	1 1/2	1	5/16	3/4	3/4	1/2	5/8	3 3/4	2 3/8
3 1/4	1 1/4	.751	5/8	3 3/4	1/2	—	1 3/4	1 1/4	3/8	1 1/4	1	3/4	3/4	4 1/4	2 5/8
4	1 1/4	.751	5/8	4 1/2	1/2	—	1 3/4	1 1/4	3/8	1 1/4	1	3/4	3/4	4 1/4	2 5/8
5	1 1/4	.751	5/8	5 1/2	1/2	5/8	1 3/4	1 1/4	7/16	1 1/4	1	3/4	3/4	4 1/2	2 7/8
6	1 1/2	1.001	3/4	6 1/2	3/4	3/4	2	1 1/2	7/16	1 1/2	1 1/4	1	1	5	3 1/8

† On 1 1/2", 2" and 2 1/2" bore sizes, the head-end (only) pipe thread is not full depth on cylinders with maximum oversize rods. Minimum of three full threads available.

■ 1" bore head is 1 3/4" x 1 1/2".

* In 1" bore size model only, a single eye mounting, 7/16" thick, is used. Dimension CD (.441") is hole diameter — pin not supplied.

• Dimension CD is pin diameter except in 1" bore.

Table 2—Rod End Dimensions and Envelope Dimensions Affected By Rod Size

Bore	MM Rod Ø	Thread		Rod Extensions and Envelope Dimensions Affected By Rod Size											Add Stroke	
		Style 5 IM	Style 2 & 4 KK	A	B Ø +.000 -.002	C	D	NA	V	VA	VB	W	WF	Y	XC	ZC
		1	1/2	7/16-20	5/16-20	5/8	.999	3/8	3/8	7/16	1/4	—	—	5/8	—	1 5/16
	5/8	1/2-20	7/16-20	3/4	1.124	3/8	1/2	9/16	1/4	—	—	5/8	—	1 5/16	5	5 7/16
1 1/2	5/8	1/2-20	7/16-20	3/4	1.124	3/8	1/2	9/16	—	1/4	3/16	—	1	1 5/16	5 3/8	5 7/8
	1	7/8-14	3/4-16	1 1/8	1.499	1/2	7/8	15/16	1/2	—	—	1	—	2 5/16	5 3/4	6 1/4
2	5/8	1/2-20	7/16-20	3/4	1.124	3/8	1/2	9/16	—	1/4	3/16	—	1	1 5/16	5 3/8	5 7/8
	1 3/8	1 1/4-12	1-14	1 5/8	1.999	5/8	1 1/8	1 5/16	5/8	—	—	1 1/4	—	2 9/16	6	6 1/2
	1	7/8-14	3/4-16	1 1/8	1.499	1/2	7/8	15/16	—	1/4	3/8	—	1 3/8	2 5/16	5 3/4	6 1/4
2 1/2	5/8	1/2-20	7/16-20	3/4	1.124	3/8	1/2	9/16	—	1/4	3/16	—	1	1 5/16	5 1/2	6
	1 3/4	1 1/2-12	1 1/4-12	2	2.374	3/4	1 1/2	1 11/16	3/4	—	—	1 1/2	—	2 3/16	6 3/8	6 7/8
	1	7/8-14	3/4-16	1 1/8	1.499	1/2	7/8	15/16	—	1/4	3/8	—	1 3/8	2 5/16	5 7/8	6 3/8
	1 5/8	1 1/4-12	1-14	1 5/8	1.999	5/8	1 1/8	1 5/16	5/8	—	—	1 1/4	1 5/8	2 7/16	6 1/8	6 5/8
3 1/4	1	7/8-14	3/4-16	1 1/8	1.499	1/2	7/8	15/16	—	1/4	3/8	—	1 3/8	2 7/16	6 7/8	7 5/8
	2	1 3/4-12	1 1/2-12	2 1/4	2.624	7/8	1 11/16	1 5/16	—	1/4	9/16	—	2	3 1/16	7 1/2	8 1/4
	1 5/8	1 1/4-12	1-14	1 5/8	1.999	5/8	1 1/8	1 5/16	—	1/4	1/2	—	1 5/8	2 11/16	7 1/8	7 7/8
	1 3/4	1 1/2-12	1 1/4-12	2	2.374	3/4	1 1/2	1 11/16	—	1/4	9/16	—	1 7/8	2 5/16	7 3/8	8 1/8
4	1	7/8-14	3/4-16	1 1/8	1.499	1/2	7/8	15/16	—	1/4	3/8	—	1 3/8	2 7/16	6 7/8	7 5/8
	2 1/2	2 1/4-12	1 7/8-12	3	3.124	1	2 1/16	2 3/8	—	1/4	1 1/16	—	2 1/4	3 5/16	7 3/4	8 1/2
	1 3/8	1 1/4-12	1-14	1 5/8	1.999	5/8	1 1/8	1 5/16	—	1/4	1/2	—	1 5/8	2 11/16	7 1/8	7 7/8
	1 3/4	1 1/2-12	1 1/4-12	2	2.374	3/4	1 1/2	1 11/16	—	1/4	9/16	—	1 7/8	2 5/16	7 3/8	8 1/8
	2	1 3/4-12	1 1/2-12	2 1/4	2.624	7/8	1 11/16	1 5/16	—	1/4	9/16	—	2	3 1/16	7 1/2	8 1/4
5	1	7/8-14	3/4-16	1 1/8	1.499	1/2	7/8	15/16	—	1/4	3/8	—	1 3/8	2 7/16	7 1/8	7 7/8
	3 1/2	3 1/4-12	2 1/2-12	3 1/2	4.249	1	3	3 3/8	5/8	—	—	1 5/8	—	3 5/16	8	8 3/4
	1 5/8	1 1/4-12	1-14	1 5/8	1.999	5/8	1 1/8	1 5/16	—	1/4	1/2	—	1 5/8	2 11/16	7 3/8	8 1/8
	1 3/4	1 1/2-12	1 1/4-12	2	2.374	3/4	1 1/2	1 11/16	—	1/4	9/16	—	1 7/8	2 5/16	7 5/8	8 3/8
	2	1 3/4-12	1 1/2-12	2 1/4	2.624	7/8	1 11/16	1 5/16	—	1/4	9/16	—	2	3 1/16	7 3/4	8 1/2
	2 1/2	2 1/4-12	1 7/8-12	3	3.124	1	2 1/16	2 3/8	—	1/4	1 1/16	—	2 1/4	3 5/16	8	8 3/4
	3	2 3/4-12	2 1/4-12	3 1/2	3.749	1	2 5/8	2 7/8	5/8	—	—	1 5/8	—	3 5/16	8	8 3/4
6	1 5/8	1 1/4-12	1-14	1 5/8	1.999	5/8	1 1/8	1 5/16	—	1/4	7/16	—	1 5/8	2 13/16	8 1/8	9 1/8
	4	3 3/4-12	3-12	4	4.749	1	3 3/8	3 7/8	1/2	—	—	1 1/2	—	3 7/16	8 3/4	9 3/4
	1 3/4	1 1/2-12	1 1/4-12	2	2.374	3/4	1 1/2	1 11/16	—	1/4	9/16	—	1 7/8	3 1/16	8 3/8	9 3/8
	2	1 3/4-12	1 1/2-12	2 1/4	2.624	7/8	1 11/16	1 5/16	—	1/4	9/16	—	2	3 3/16	8 1/2	9 1/2
	2 1/2	2 1/4-12	1 7/8-12	3	3.124	1	2 1/16	2 3/8	—	1/4	1 1/16	—	2 1/4	3 7/16	8 3/4	9 3/4
	3	2 3/4-12	2 1/4-12	3 1/2	3.749	1	2 5/8	2 7/8	1/2	—	—	1 1/2	—	3 7/16	8 3/4	9 3/4
	3 1/2	3 1/4-12	2 1/2-12	3 1/2	4.249	1	3	3 3/8	1/2	—	—	1 1/2	—	3 7/16	8 3/4	9 3/4

Miller AV Series Heavy-Duty Air Cylinders

Double Rod End Cylinders
1" to 6" Bore Sizes

Double Rod End Cylinders

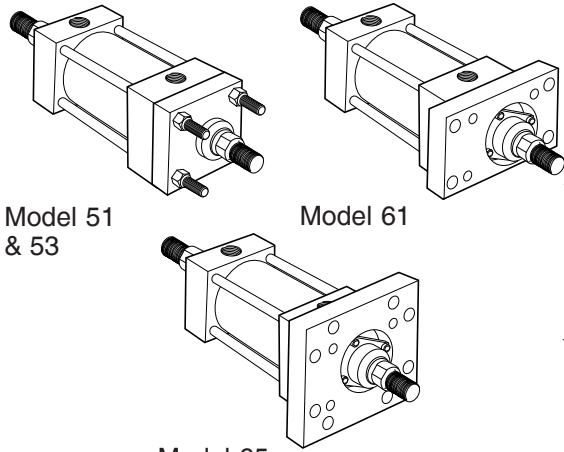

Retainer Held Bushing

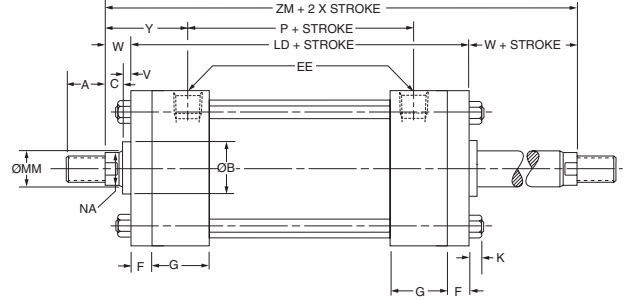
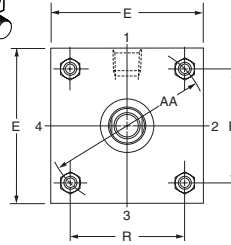

Note: The basic double rod cylinder dimensions are shown on this and facing page. For specific mounting dimensions, refer to pages for single rod cylinder. Exception: Model 72, "SS".

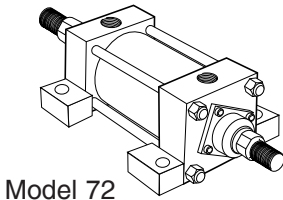

Model 72

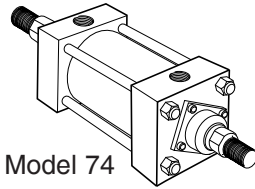

Model 74

Bolted Bushing

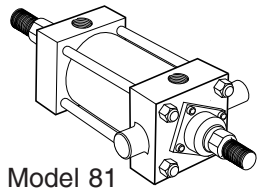
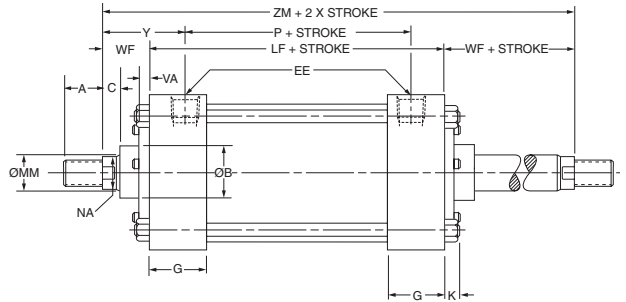
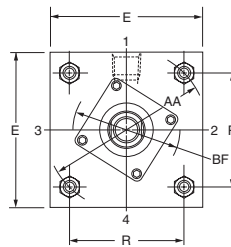

Model 81

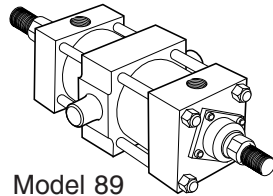

Model 89

Rod End Dimensions — see table 2

Thread Style 2 Small Male

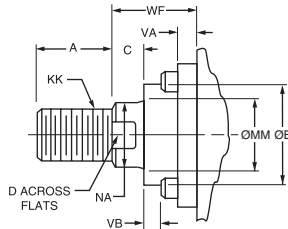

A high strength rod end stud is supplied on thread style 2 through 2" diameter rods and on thread style 5 through 1³/₈" diameter rods. Larger sizes or special rod ends are cut threads. Style 2 rod ends are recommended where the workpiece is secured against the rod shoulder. When the workpiece is not shouldered, style 2 rod ends

Thread Style 4 Short Female

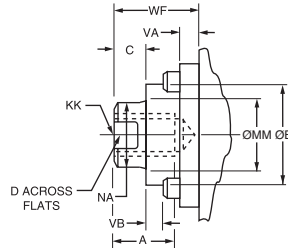

are recommended through 2" piston rod diameters and style 5 rod ends are recommended on larger diameters. Use style 4 for applications where female rod end threads are required. If rod end is not specified, style 2 will be supplied.

Thread Style 5 Intermediate Male

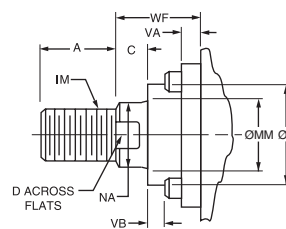

"Special" Thread Style X

Special thread, extension, rod eye, blank, etc., are also available.

To order, specify "Style X" and give desired dimensions for KK, A, W or WF. If otherwise special, furnish dimensioned sketch.

Miller AV Series Heavy-Duty Air Cylinders

Double Rod End Cylinders
1" to 6" Bore Sizes

Table 1—Envelope and Mounting Dimensions

Bore	E	EE NPTF	F	G	K	SS	Add Stroke		
							LD	LF	P
1	■	1/4	3/8	1 1/2	3/16	3 3/8	4 3/4	—	2 1/8
1 1/2	2	3/8†	3/8	1 1/2	1/4	3 3/8	4 7/8	4 1/8	2 1/4
2	2 1/2	3/8†	3/8	1 1/2	5/16	3 3/8	4 7/8	4 1/8	2 1/4
2 1/2	3	3/8†	3/8	1 1/2	5/16	3 1/2	5	4 1/4	2 3/8
3 1/4	3 3/4	1/2	5/8	1 3/4	3/8	3 3/4	6	4 3/4	2 5/8
4	4 1/2	1/2	5/8	1 3/4	3/8	3 3/4	6	4 3/4	2 5/8
5	5 1/2	1/2	5/8	1 3/4	7/16	3 5/8	6 1/4	5	2 7/8
6	6 1/2	3/4	3/4	2	7/16	4 1/8	7	5 1/2	3 1/8

† On 1 1/2", 2" and 2 1/2" bore sizes, the head-end (only) pipe thread is not full depth on cylinders with maximum oversize rods. Minimum of three full threads available.

■ 1" bore head is 1 3/4" x 1 1/2".

How to Use Double Rod Cylinder Dimension Drawings

To determine dimensions for a double rod cylinder, first refer to the desired single rod mounting style cylinder shown on preceding pages of this catalog. After selecting necessary dimensions from that drawing, return to this page and supplement the single rod dimensions with those shown on the drawing and dimension table below. Note that double rod cylinders have a head (Dim. G) at both ends and that dimension LD replaces LB. The double rod dimensions differ from, or are in addition to those for single rod cylinders shown on preceding pages and provide the information needed to completely dimension a double rod cylinder. On a double rod cylinder where the two rod ends are different, be sure to clearly state which rod end is to be assembled at which end.

Port position 1 is standard. If other than standard, specify position 2, 3, or 4 when viewed from one end only.

Table 2—Rod End Dimensions and Envelope Dimensions Affected By Rod Size

Bore	MM Rod Ø	Thread		Rod Extensions and Envelope Dimensions Affected By Rod Size													Add Stroke ZM
		Style 5 IM	Style 2 & 4 KK	A	B Ø +.000 -.002	BF	C	D	NA	V	VA	VB	Y	W	WF		
1	1/2	7/16-20	5/16-24	5/8	.999	—	3/8	3/8	7/16	1/4	—	—	1 5/16	5/8	—	6	
	5/8	1/2-20	7/16-20	3/4	1.124	—	3/8	1/2	9/16	1/4	—	—	1 5/16	5/8	—	6	
1 1/2	5/8	1/2-20	7/16-20	3/4	1.124	1.968	3/8	1/2	9/16	—	1/4	3/16	1 5/16	5/8	1	6 1/8	
	1	7/8-14	3/4-16	1 1/8	1.499	—	1/2	7/8	15/16	1/2	—	—	2 5/16	1	—	6 7/8	
2	5/8	1/2-20	7/16-20	3/4	1.124	1.968	3/8	1/2	9/16	—	1/4	3/16	1 5/16	5/8	1	6 1/8	
	1 3/8	1 1/4-12	1-14	1 5/8	1.999	—	5/8	1 1/8	1 5/16	5/8	—	—	2 9/16	1 1/4	—	7 3/8	
2 1/2	1	7/8-14	3/4-16	1 1/8	1.499	2.468	1/2	7/8	15/16	—	1/4	3/8	2 5/16	1	1 3/8	6 7/8	
	5/8	1/2-20	7/16-20	3/4	1.124	1.968	3/8	1/2	9/16	—	1/4	3/16	1 5/16	5/8	1	6 1/4	
3 1/4	1 3/4	1 1/2-12	1 1/4-12	2	2.374	—	3/4	1 1/2	1 11/16	3/4	—	—	2 13/16	1 1/2	—	8	
	1	7/8-14	3/4-16	1 1/8	1.499	2.468	1/2	7/8	15/16	—	1/4	3/8	2 5/16	1	1 3/8	7	
4	1 3/8	1 1/4-12	1-14	1 5/8	1.999	2.968	5/8	1 1/8	1 5/16	5/8	—	—	2 9/16	1 1/4	—	7 1/2	
	1	7/8-14	3/4-16	1 1/8	1.499	2.468	1/2	7/8	15/16	—	1/4	3/8	2 7/16	3/4	1 3/8	7 1/2	
5	2	1 3/4-12	1 1/2-12	2 1/4	2.624	3.735	7/8	1 11/16	1 5/16	—	1/4	9/16	3 1/16	1 3/8	2	8 3/4	
	1 3/8	1 1/4-12	1-14	1 5/8	1.999	2.968	5/8	1 1/8	1 5/16	—	1/4	3/16	2 11/16	1	1 5/8	8	
6	1 3/4	1 1/2-12	1 1/4-12	2	2.374	3.625	3/4	1 1/2	1 11/16	—	1/4	9/16	2 15/16	1 1/4	1 7/8	8 1/2	
	1	7/8-14	3/4-16	1 1/8	1.499	2.468	1/2	7/8	15/16	—	1/4	3/8	2 7/16	3/4	1 3/8	7 1/2	
7	2 1/2	2 1/4-12	1 7/8-12	3	3.124	4.312	1	2 1/16	2 3/8	—	1/4	1 1/16	3 3/16	1 5/8	2 1/4	9 1/4	
	1 3/8	1 1/4-12	1-14	1 5/8	1.999	2.968	5/8	1 1/8	1 5/16	—	1/4	3/8	2 7/16	3/4	1 3/8	7 3/4	
8	3 1/2	3 1/4-12	2 1/2-12	3 1/2	4.249	—	1	3	3 3/8	5/8	—	—	3 5/16	1 5/8	—	9 1/2	
	1 3/8	1 1/4-12	1-14	1 5/8	1.999	2.968	5/8	1 1/8	1 5/16	—	1/4	1/2	2 11/16	1	1 5/8	8 1/4	
9	1 3/4	1 1/2-12	1 1/4-12	2	2.374	3.625	3/4	1 1/2	1 11/16	—	1/4	9/16	2 15/16	1 1/4	1 7/8	8 3/4	
	2	1 3/4-12	1 1/2-12	2 1/4	2.624	3.735	7/8	1 11/16	1 5/16	—	1/4	9/16	3 1/16	1 3/8	2	9	
10	2 1/2	2 1/4-12	1 7/8-12	3	3.124	4.312	1	2 1/16	2 3/8	—	1/4	1 1/16	3 5/16	1 5/8	2 1/4	9 1/2	
	3	2 3/4-12	2 1/4-12	3 1/2	3.749	—	1	2 5/8	2 7/8	5/8	—	—	3 5/16	1 5/8	—	9 1/2	
11	1 3/8	1 1/4-12	1-14	1 5/8	1.999	2.968	5/8	1 1/8	1 5/16	—	1/4	7/16	2 13/16	7/8	1 5/8	8 3/4	
	4	3 3/4-12	3-12	4	4.749	—	1	3 3/8	3 7/8	1/2	—	—	3 7/16	1 1/2	—	10	
12	1 3/4	1 1/2-12	1 1/4-12	2	2.374	3.625	3/4	1 1/2	1 11/16	—	1/4	9/16	3 1/16	1 1/8	1 7/8	9 1/4	
	2	1 3/4-12	1 1/2-12	2 1/4	2.624	3.735	7/8	1 11/16	1 5/16	—	1/4	9/16	3 3/16	1 1/4	2	9 1/2	
13	2 1/2	2 1/4-12	1 7/8-12	3	3.124	4.312	1	2 1/16	2 3/8	—	1/4	1 1/16	3 1/16	1 1/2	2 1/4	10	
	3	2 3/4-12	2 1/4-12	3 1/2	3.749	—	1	2 5/8	2 7/8	1/2	—	—	3 7/16	1 1/2	—	10	
14	3 1/2	3 1/4-12	2 1/2-12	3 1/2	4.249	—	1	3	3 3/8	1/2	—	—	3 7/16	1 1/2	—	10	

Miller AV Series Heavy-Duty Air Cylinders

Side Lug Mount – 7" to 14" Bore Sizes
Side Tap Mount – 7" to 14" Bore Sizes

Side Lug Mount Model 72 7" - 14" Bore

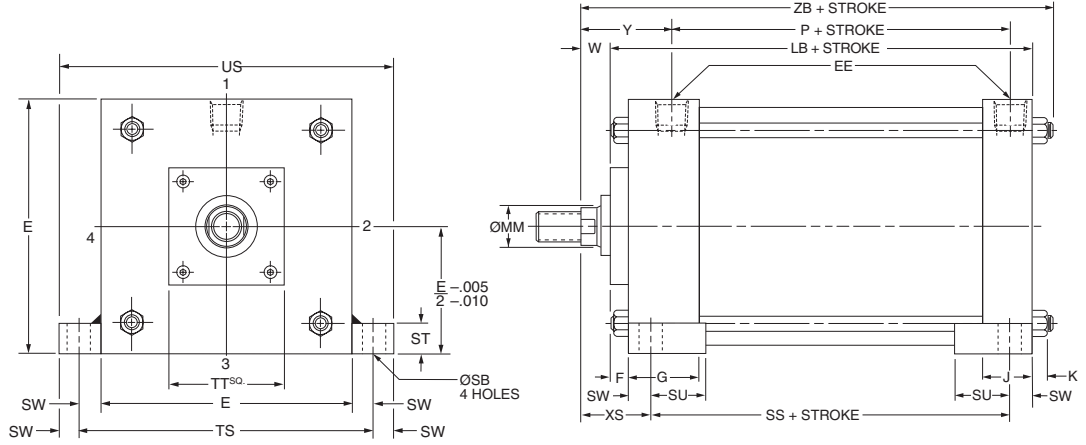
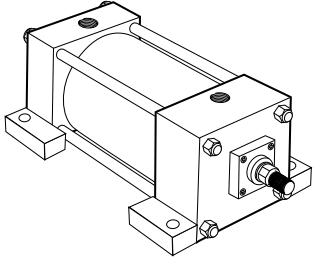

Side Tap Mount Model 74 7" - 14" Bore

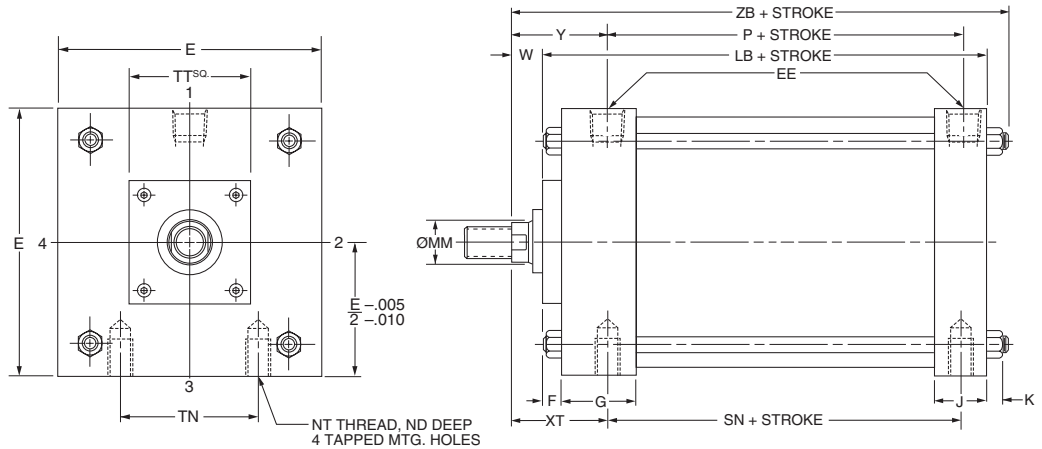
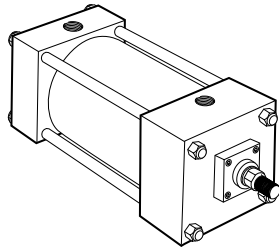

Rod End Dimensions — see table 2

Thread Style 2 Small Male

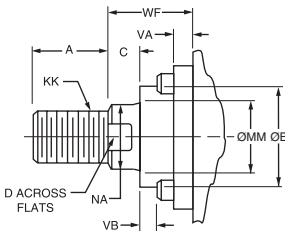

A high strength rod end stud is supplied on thread style 2 through 2" diameter rods and on thread style 5 through 1 3/8" diameter rods. Larger sizes or special rod ends are cut threads. Style 2 rod ends are recommended where the workpiece is secured against the rod shoulder. When the workpiece is not shouldered, style 2 rod ends

Thread Style 4 Short Female

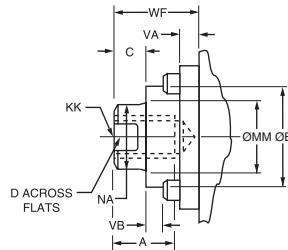

are recommended through 2" piston rod diameters and style 5 rod ends are recommended on larger diameters. Use style 4 for applications where female rod end threads are required. If rod end is not specified, style 2 will be supplied.

Thread Style 5 Intermediate Male

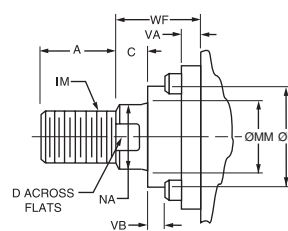

"Special" Thread Style X

Special thread, extension, rod eye, blank, etc., are also available.

To order, specify "Style X" and give desired dimensions for KK, A and WF. If otherwise special, furnish dimensioned sketch.

Miller AV Series Heavy-Duty Air Cylinders

Side Lug Mount – 7" to 14" Bore Sizes
Side Tap Mount – 7" to 14" Bore Sizes

Table 1—Envelope and Mounting Dimensions

Bore	E	EE NPTF	F	G	J	K	ND	NT	SB* (Bolt)	ST	SU	SW	TN	TS	US	Add Stroke			
																LB	P	SN	SS
7	7 ¹ / ₂	³ / ₄	³ / ₄	2	1 ¹ / ₂	⁹ / ₁₆	1 ¹ / ₈	³ / ₄ -10	³ / ₄	1	1 ⁹ / ₁₆	¹¹ / ₁₆	3 ¹ / ₂	8 ⁷ / ₈	10 ¹ / ₄	5 ⁷ / ₈	3 ¹ / ₄	3 ¹ / ₄	3 ³ / ₄
8	8 ¹ / ₂	³ / ₄	³ / ₄	2	1 ¹ / ₂	⁹ / ₁₆	1 ¹ / ₈	³ / ₄ -10	³ / ₄	1	1 ⁹ / ₁₆	¹¹ / ₁₆	4 ¹ / ₂	9 ⁷ / ₈	11 ¹ / ₄	5 ⁷ / ₈	3 ¹¹ / ₄	3 ¹ / ₄	3 ³ / ₄
10	10 ⁵ / ₈	1	³ / ₄	2 ¹ / ₄	2	¹¹ / ₁₆	1 ¹ / ₂	1-8	1	1 ¹ / ₄	2	⁷ / ₈	5 ¹ / ₂	12 ³ / ₈	14 ¹ / ₈	7 ¹ / ₈	4 ¹ / ₈	4 ¹ / ₈	4 ⁵ / ₈
12	12 ³ / ₄	1	³ / ₄	2 ¹ / ₄	2	¹¹ / ₁₆	1 ¹ / ₂	1-8	1	1 ¹ / ₄	2	⁷ / ₈	7 ¹ / ₄	14 ¹ / ₂	16 ¹ / ₄	7 ⁵ / ₈	4 ⁵ / ₈	4 ⁵ / ₈	5 ¹ / ₈
14	14 ³ / ₄	1 ¹ / ₄	³ / ₄	2 ³ / ₄	2 ¹ / ₄	³ / ₄	1 ⁷ / ₈	1 ¹ / ₄ -7	1 ¹ / ₄	1 ¹ / ₂	2 ¹ / ₂	1 ¹ / ₈	8 ³ / ₈	17	19 ¹ / ₄	8 ⁷ / ₈	5 ¹ / ₂	5 ¹ / ₂	5 ⁷ / ₈

*Mounting holes are ¹/₁₆" larger than bolt size listed.

Table 2—Rod End Dimensions and Envelope Dimensions Affected By Rod Size

Bore	MM Rod Ø	Thread		Rod End Dimensions and Envelope Dimensions Affected By Rod Size												Add Stroke ZB
		Style 5 IM	Style 2 & 4 KK	A	B Ø +.000 -.002	C	D	NA	TT	V	W	XS	XT	Y		
7	1 ³ / ₈	1 ¹ / ₄ -12	1-14	1 ⁵ / ₈	1.999	⁵ / ₈	1 ¹ / ₈	1 ⁵ / ₁₆	4	¹ / ₄	⁷ / ₈	2 ⁵ / ₁₆	2 ¹³ / ₁₆	2 ¹³ / ₁₆	7 ⁵ / ₁₆	
	1 ³ / ₄	1 ¹ / ₂ -12	1 ¹ / ₄ -12	2	2.374	³ / ₄	1 ¹ / ₂	1 ¹¹ / ₁₆	4	³ / ₈	1 ¹ / ₈	2 ⁹ / ₁₆	3 ¹ / ₁₆	3 ¹ / ₁₆	7 ⁹ / ₁₆	
	2	1 ³ / ₄ -12	1 ¹ / ₂ -12	2 ¹ / ₄	2.624	⁷ / ₈	1 ¹¹ / ₁₆	1 ¹⁵ / ₁₆	4	³ / ₈	1 ¹ / ₄	2 ¹¹ / ₁₆	3 ³ / ₁₆	3 ³ / ₁₆	7 ¹¹ / ₁₆	
8	1 ³ / ₈	1 ¹ / ₄ -12	1-14	1 ⁵ / ₈	1.999	⁵ / ₈	1 ¹ / ₈	1 ⁵ / ₁₆	4	¹ / ₄	⁷ / ₈	2 ⁵ / ₁₆	2 ¹³ / ₁₆	2 ¹³ / ₁₆	7 ⁵ / ₁₆	
	5 ¹ / ₂	5 ¹ / ₄ -12	4-12	5 ¹ / ₂	6.249	1	4 ⁵ / ₈	5 ³ / ₈	7	¹ / ₂	1 ¹ / ₂	2 ¹⁵ / ₁₆	3 ⁷ / ₁₆	3 ⁷ / ₁₆	7 ¹⁵ / ₁₆	
	1 ³ / ₄	1 ¹ / ₂ -12	1 ¹ / ₄ -12	2	2.374	³ / ₄	1 ¹ / ₂	1 ¹¹ / ₁₆	4	³ / ₈	1 ¹ / ₈	2 ⁹ / ₁₆	3 ¹ / ₁₆	3 ¹ / ₁₆	7 ⁹ / ₁₆	
	2	1 ³ / ₄ -12	1 ¹ / ₂ -12	2 ¹ / ₄	2.624	⁷ / ₈	1 ¹¹ / ₁₆	1 ¹⁵ / ₁₆	4	³ / ₈	1 ¹ / ₄	2 ¹¹ / ₁₆	3 ³ / ₁₆	3 ³ / ₁₆	7 ¹¹ / ₁₆	
	2 ¹ / ₂	2 ¹ / ₄ -12	1 ⁷ / ₈ -12	3	3.124	1	2 ¹ / ₁₆	2 ³ / ₈	4	¹ / ₂	1 ¹ / ₂	2 ¹⁵ / ₁₆	3 ⁷ / ₁₆	3 ⁷ / ₁₆	7 ¹⁵ / ₁₆	
	3	2 ³ / ₄ -12	2 ¹ / ₄ -12	3 ¹ / ₂	3.749	1	2 ⁵ / ₈	2 ⁷ / ₈	5 ¹ / ₂	¹ / ₂	1 ¹ / ₂	2 ¹⁵ / ₁₆	3 ⁷ / ₁₆	3 ⁷ / ₁₆	7 ¹⁵ / ₁₆	
	3 ¹ / ₂	3 ¹ / ₄ -12	2 ¹ / ₂ -12	3 ¹ / ₂	4.249	1	3	3 ³ / ₈	5 ¹ / ₂	¹ / ₂	1 ¹ / ₂	2 ¹⁵ / ₁₆	3 ⁷ / ₁₆	3 ⁷ / ₁₆	7 ¹⁵ / ₁₆	
	4	3 ³ / ₄ -12	3-12	4	4.749	1	3 ³ / ₈	3 ⁷ / ₈	5 ¹ / ₂	¹ / ₂	1 ¹ / ₂	2 ¹⁵ / ₁₆	3 ⁷ / ₁₆	3 ⁷ / ₁₆	7 ¹⁵ / ₁₆	
	4 ¹ / ₂	4 ¹ / ₄ -12	3 ¹ / ₄ -12	4 ¹ / ₂	5.249	1	3 ⁷ / ₈	4 ³ / ₈	7	¹ / ₂	1 ¹ / ₂	2 ¹⁵ / ₁₆	3 ⁷ / ₁₆	3 ⁷ / ₁₆	7 ¹⁵ / ₁₆	
5	4 ³ / ₄ -12	3 ¹ / ₂ -12	5	5.749	1	4 ¹ / ₄	4 ⁷ / ₈	7	¹ / ₂	1 ¹ / ₂	2 ¹⁵ / ₁₆	3 ⁷ / ₁₆	3 ⁷ / ₁₆	7 ¹⁵ / ₁₆		
10	1 ³ / ₄	1 ¹ / ₂ -12	1 ¹ / ₄ -12	2	2.374	³ / ₄	1 ¹ / ₂	1 ¹¹ / ₁₆	4	³ / ₈	1 ¹ / ₈	2 ³ / ₄	3 ¹ / ₈	3 ¹ / ₈	8 ⁵ / ₁₆	
	2	1 ³ / ₄ -12	1 ¹ / ₂ -12	2 ¹ / ₄	2.624	⁷ / ₈	1 ¹¹ / ₁₆	1 ¹⁵ / ₁₆	4	³ / ₈	1 ¹ / ₄	2 ⁷ / ₈	3 ¹ / ₄	3 ¹ / ₄	9 ¹ / ₁₆	
	2 ¹ / ₂	2 ¹ / ₄ -12	1 ⁷ / ₈ -12	3	3.124	1	2 ¹ / ₁₆	2 ³ / ₈	4	¹ / ₂	1 ¹ / ₂	3 ¹ / ₈	3 ¹ / ₂	3 ¹ / ₂	9 ⁵ / ₁₆	
	3	2 ³ / ₄ -12	2 ¹ / ₄ -12	3 ¹ / ₂	3.749	1	2 ⁵ / ₈	2 ⁷ / ₈	5 ¹ / ₂	¹ / ₂	1 ¹ / ₂	3 ¹ / ₈	3 ¹ / ₂	3 ¹ / ₂	9 ⁵ / ₁₆	
	3 ¹ / ₂	3 ¹ / ₄ -12	2 ¹ / ₂ -12	3 ¹ / ₂	4.249	1	3	3 ³ / ₈	5 ¹ / ₂	¹ / ₂	1 ¹ / ₂	3 ¹ / ₈	3 ¹ / ₂	3 ¹ / ₂	9 ⁵ / ₁₆	
	4	3 ³ / ₄ -12	3-12	4	4.749	1	3 ³ / ₈	3 ⁷ / ₈	5 ¹ / ₂	¹ / ₂	1 ¹ / ₂	3 ¹ / ₈	3 ¹ / ₂	3 ¹ / ₂	9 ⁵ / ₁₆	
	4 ¹ / ₂	4 ¹ / ₄ -12	3 ¹ / ₄ -12	4 ¹ / ₂	5.249	1	3 ⁷ / ₈	4 ³ / ₈	7	¹ / ₂	1 ¹ / ₂	3 ¹ / ₈	3 ¹ / ₂	3 ¹ / ₂	9 ⁵ / ₁₆	
	5	4 ³ / ₄ -12	3 ¹ / ₂ -12	5	5.749	1	4 ¹ / ₄	4 ⁷ / ₈	7	¹ / ₂	1 ¹ / ₂	3 ¹ / ₈	3 ¹ / ₂	3 ¹ / ₂	9 ⁵ / ₁₆	
5 ¹ / ₂	5 ¹ / ₄ -12	4-12	5 ¹ / ₂	6.249	1	4 ⁵ / ₈	5 ³ / ₈	7	¹ / ₂	1 ¹ / ₂	3 ¹ / ₈	3 ¹ / ₂	3 ¹ / ₂	9 ⁵ / ₁₆		
12	2	1 ³ / ₄ -12	1 ¹ / ₂ -12	2 ¹ / ₄	2.624	⁷ / ₈	1 ¹¹ / ₁₆	1 ¹⁵ / ₁₆	4	³ / ₈	1 ¹ / ₄	2 ⁷ / ₈	3 ¹ / ₄	3 ¹ / ₄	9 ⁹ / ₁₆	
	2 ¹ / ₂	2 ¹ / ₄ -12	1 ⁷ / ₈ -12	3	3.124	1	2 ¹ / ₁₆	2 ³ / ₈	4	¹ / ₂	1 ¹ / ₂	3 ¹ / ₈	3 ¹ / ₂	3 ¹ / ₂	9 ¹³ / ₁₆	
	3	2 ³ / ₄ -12	2 ¹ / ₄ -12	3 ¹ / ₂	3.749	1	2 ⁵ / ₈	2 ⁷ / ₈	5 ¹ / ₂	¹ / ₂	1 ¹ / ₂	3 ¹ / ₈	3 ¹ / ₂	3 ¹ / ₂	9 ¹³ / ₁₆	
	3 ¹ / ₂	3 ¹ / ₄ -12	2 ¹ / ₂ -12	3 ¹ / ₂	4.249	1	3	3 ³ / ₈	5 ¹ / ₂	¹ / ₂	1 ¹ / ₂	3 ¹ / ₈	3 ¹ / ₂	3 ¹ / ₂	9 ¹³ / ₁₆	
	4	3 ³ / ₄ -12	3-12	4	4.749	1	3 ³ / ₈	3 ⁷ / ₈	5 ¹ / ₂	¹ / ₂	1 ¹ / ₂	3 ¹ / ₈	3 ¹ / ₂	3 ¹ / ₂	9 ¹³ / ₁₆	
	4 ¹ / ₂	4 ¹ / ₄ -12	3 ¹ / ₄ -12	4 ¹ / ₂	5.249	1	3 ⁷ / ₈	4 ³ / ₈	7	¹ / ₂	1 ¹ / ₂	3 ¹ / ₈	3 ¹ / ₂	3 ¹ / ₂	9 ¹³ / ₁₆	
	5	4 ³ / ₄ -12	3 ¹ / ₂ -12	5	5.749	1	4 ¹ / ₄	4 ⁷ / ₈	7	¹ / ₂	1 ¹ / ₂	3 ¹ / ₈	3 ¹ / ₂	3 ¹ / ₂	9 ¹³ / ₁₆	
5 ¹ / ₂	5 ¹ / ₄ -12	4-12	5 ¹ / ₂	6.249	1	4 ⁵ / ₈	5 ³ / ₈	7	¹ / ₂	1 ¹ / ₂	3 ¹ / ₈	3 ¹ / ₂	3 ¹ / ₂	9 ¹³ / ₁₆		
14	2 ¹ / ₂	2 ¹ / ₄ -12	1 ⁷ / ₈ -12	3	3.124	1	2 ¹ / ₁₆	2 ³ / ₈	4	¹ / ₂	1 ¹ / ₂	3 ³ / ₈	3 ¹³ / ₁₆	3 ¹³ / ₁₆	11 ¹ / ₈	
	3	2 ³ / ₄ -12	2 ¹ / ₄ -12	3 ¹ / ₂	3.749	1	2 ⁵ / ₈	2 ⁷ / ₈	5 ¹ / ₂	¹ / ₂	1 ¹ / ₂	3 ³ / ₈	3 ¹³ / ₁₆	3 ¹³ / ₁₆	11 ¹ / ₈	
	3 ¹ / ₂	3 ¹ / ₄ -12	2 ¹ / ₂ -12	3 ¹ / ₂	4.249	1	3	3 ³ / ₈	5 ¹ / ₂	¹ / ₂	1 ¹ / ₂	3 ³ / ₈	3 ¹³ / ₁₆	3 ¹³ / ₁₆	11 ¹ / ₈	
	4	3 ³ / ₄ -12	3-12	4	4.749	1	3 ³ / ₈	3 ⁷ / ₈	5 ¹ / ₂	¹ / ₂	1 ¹ / ₂	3 ³ / ₈	3 ¹³ / ₁₆	3 ¹³ / ₁₆	11 ¹ / ₈	
	4 ¹ / ₂	4 ¹ / ₄ -12	3 ¹ / ₄ -12	4 ¹ / ₂	5.249	1	3 ⁷ / ₈	4 ³ / ₈	7	¹ / ₂	1 ¹ / ₂	3 ³ / ₈	3 ¹³ / ₁₆	3 ¹³ / ₁₆	11 ¹ / ₈	
	5	4 ³ / ₄ -12	3 ¹ / ₂ -12	5	5.749	1	4 ¹ / ₄	4 ⁷ / ₈	7	¹ / ₂	1 ¹ / ₂	3 ³ / ₈	3 ¹³ / ₁₆	3 ¹³ / ₁₆	11 ¹ / ₈	
5 ¹ / ₂	5 ¹ / ₄ -12	4-12	5 ¹ / ₂	6.249	1	4 ⁵ / ₈	5 ³ / ₈	7	¹ / ₂	1 ¹ / ₂	3 ³ / ₈	3 ¹³ / ₁₆	3 ¹³ / ₁₆	11 ¹ / ₈		

* Mounting style MS1 not offered in this rod size.

Miller AV Series Heavy-Duty Air Cylinders

Head Square Mount
Cap Square Mount
7" to 14" Bore Sizes

Head Square Mount Model 63 7" - 14" Bore

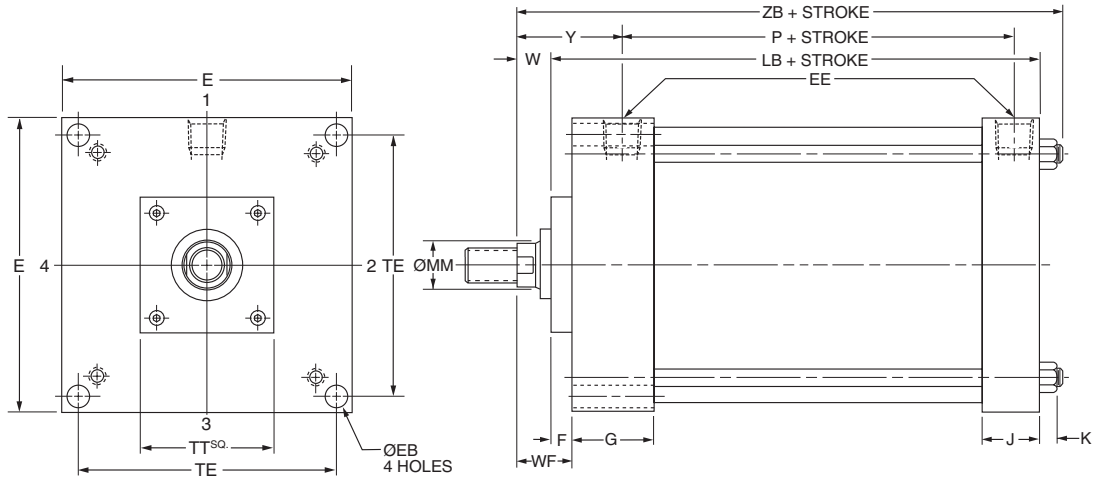
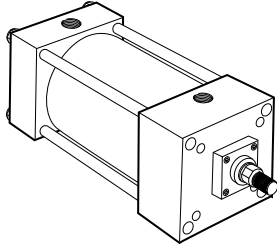

Cap Square Mount Model 64 7" - 14" Bore

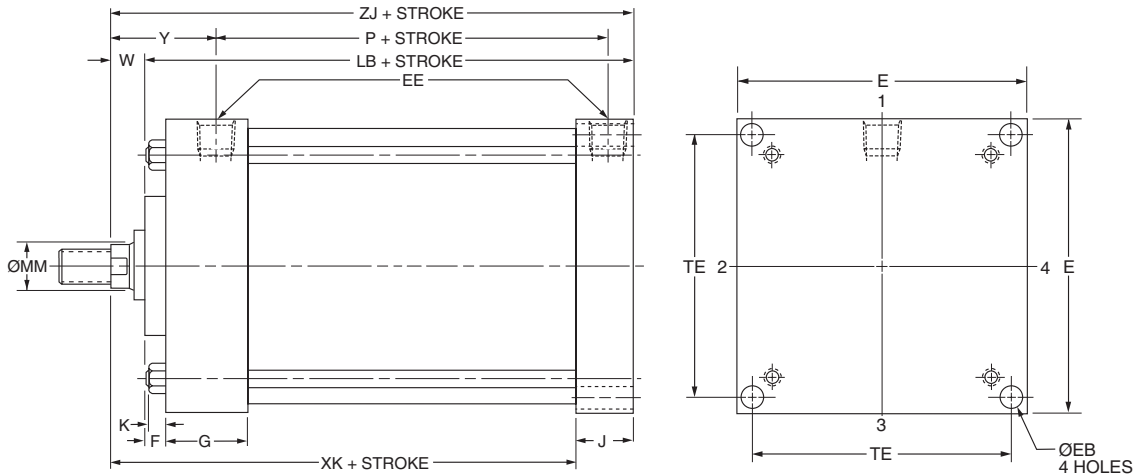
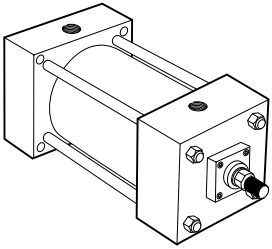

Rod End Dimensions — see table 2

Thread Style 2 Small Male

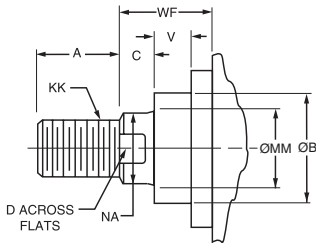

Thread Style 4 Short Female

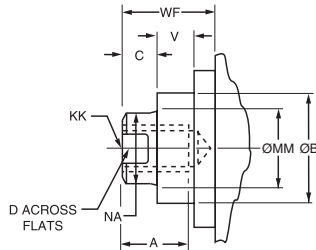

Thread Style 5 Intermediate Male

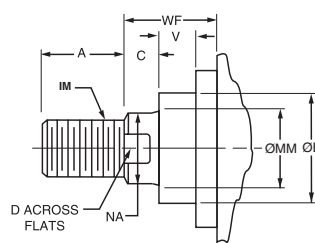

“Special” Thread Style X

Special thread, extension, rod eye, blank, etc., are also available.

To order, specify “Style X” and give desired dimensions for KK, A and WF. If otherwise special, furnish dimensioned sketch.

A high strength rod end stud is supplied on thread style 2 through 2" diameter rods and on thread style 5 through 1 3/8" diameter rods. Larger sizes or special rod ends are cut threads. Style 2 rod ends are recommended where the workpiece is secured against the rod shoulder. When the workpiece is not shouldered, style 2 rod ends

are recommended through 2" piston rod diameters and style 5 rod ends are recommended on larger diameters. Use style 4 for applications where female rod end threads are required. If rod end is not specified, style 2 will be supplied.

Miller AV Series Heavy-Duty Air Cylinders

Head Square Mount
Cap Square Mount
7" to 14" Bore Sizes

Table 1—Envelope and Mounting Dimensions

Bore	E	EB* (Bolt)	EE NPTF	F	G	J	K	TE	Add Stroke	
									LB	P
7	7 ¹ / ₂	1 ¹ / ₂	3 ³ / ₄	3 ³ / ₄	2	1 ¹ / ₂	9 ⁹ / ₁₆	6.75	5 ⁵ / ₈	3 ³ / ₄
8	8 ¹ / ₂	5 ⁵ / ₈	3 ³ / ₄	3 ³ / ₄	2	1 ¹ / ₂	9 ⁹ / ₁₆	7.57	5 ⁵ / ₈	3 ³ / ₄
10	10 ⁵ / ₈	3 ³ / ₄	1	3 ³ / ₄	2 ¹ / ₄	2	1 ¹¹ / ₁₆	9.40	7 ⁷ / ₈	4 ⁴ / ₈
12	12 ³ / ₄	3 ³ / ₄	1	3 ³ / ₄	2 ¹ / ₄	2	1 ¹¹ / ₁₆	11.10	7 ⁵ / ₈	4 ⁵ / ₈
14	14 ³ / ₄	7 ⁷ / ₈	1 ¹ / ₄	3 ³ / ₄	2 ³ / ₄	2 ¹ / ₄	3 ³ / ₄	12.87	8 ⁷ / ₈	5 ¹ / ₂

*Mounting holes are 1/16" larger than bolt size listed.

Table 2—Rod End Dimensions and Envelope Dimensions Affected By Rod Size

Bore	MM Rod Ø	Thread		Rod End Dimensions and Envelope Dimensions Affected By Rod Size													Add Stroke ZJ
		Style 5 IM	Style 2 & 4 KK	A	B Ø +.000 -.002	C	D	NA	TT	V	W	WF	XK	Y	ZB		
																Z	
7	1 ³ / ₈	1 ¹ / ₄ -12	1-14	1 ⁵ / ₈	1.999	5 ⁵ / ₈	1 ¹ / ₈	1 ⁵ / ₁₆	4	1 ¹ / ₄	7 ⁷ / ₈	1 ⁵ / ₈	5 ¹ / ₄	2 ¹³ / ₁₆	7 ⁵ / ₁₆	6 ³ / ₄	
	1 ³ / ₄	1 ¹ / ₂ -12	1 ¹ / ₄ -12	2	2.374	3 ³ / ₄	1 ¹ / ₂	1 ¹¹ / ₁₆	4	3 ³ / ₈	1 ¹ / ₈	1 ⁷ / ₈	5 ¹ / ₂	3 ¹ / ₁₆	7 ⁹ / ₁₆	7	
	2	1 ³ / ₄ -12	1 ¹ / ₂ -12	2 ¹ / ₄	2.624	7 ⁷ / ₈	1 ¹¹ / ₁₆	1 ¹⁵ / ₁₆	4	3 ³ / ₈	1 ¹ / ₄	2	5 ⁷ / ₈	3 ³ / ₁₆	7 ¹¹ / ₁₆	7 ¹ / ₈	
8	1 ³ / ₈	1 ¹ / ₄ -12	1-14	1 ⁵ / ₈	1.999	5 ⁵ / ₈	1 ¹ / ₈	1 ⁵ / ₁₆	4	1 ¹ / ₄	7 ⁷ / ₈	1 ⁵ / ₈	5 ¹ / ₄	2 ¹³ / ₁₆	7 ⁵ / ₁₆	6 ³ / ₄	
	5 ¹ / ₂	5 ¹ / ₄ -12	4-12	5 ¹ / ₂	6.249	1	4 ⁵ / ₈	5 ³ / ₈	7	1 ¹ / ₂	1 ¹ / ₂	2 ¹ / ₄	5 ⁷ / ₈	3 ⁷ / ₁₆	7 ¹⁵ / ₁₆	7 ³ / ₈	
	1 ³ / ₄	1 ¹ / ₂ -12	1 ¹ / ₄ -12	2	2.374	3 ³ / ₄	1 ¹ / ₂	1 ¹¹ / ₁₆	4	3 ³ / ₈	1 ¹ / ₈	1 ⁷ / ₈	5 ¹ / ₂	3 ¹ / ₁₆	7 ⁹ / ₁₆	7	
	2	1 ³ / ₄ -12	1 ¹ / ₂ -12	2 ¹ / ₄	2.624	7 ⁷ / ₈	1 ¹¹ / ₁₆	1 ¹⁵ / ₁₆	4	3 ³ / ₈	1 ¹ / ₄	2	5 ⁵ / ₈	3 ³ / ₁₆	7 ¹¹ / ₁₆	7 ¹ / ₈	
	2 ¹ / ₂	2 ¹ / ₄ -12	1 ⁷ / ₈ -12	3	3.124	1	2 ¹ / ₁₆	2 ³ / ₈	4	1 ¹ / ₂	1 ¹ / ₂	2 ¹ / ₄	5 ⁷ / ₈	3 ⁷ / ₁₆	7 ¹⁵ / ₁₆	7 ³ / ₈	
	3	2 ³ / ₄ -12	2 ¹ / ₄ -12	3 ¹ / ₂	3.749	1	2 ⁵ / ₈	2 ⁷ / ₈	5 ¹ / ₂	1 ¹ / ₂	1 ¹ / ₂	2 ¹ / ₄	5 ⁷ / ₈	3 ⁷ / ₁₆	7 ¹⁵ / ₁₆	7 ³ / ₈	
	3 ¹ / ₂	3 ¹ / ₄ -12	2 ¹ / ₂ -12	3 ¹ / ₂	4.249	1	3	3 ³ / ₈	5 ¹ / ₂	1 ¹ / ₂	1 ¹ / ₂	2 ¹ / ₄	5 ⁷ / ₈	3 ⁷ / ₁₆	7 ¹⁵ / ₁₆	7 ³ / ₈	
	4	3 ³ / ₄ -12	3-12	4	4.749	1	3 ³ / ₈	3 ⁷ / ₈	5 ¹ / ₂	1 ¹ / ₂	1 ¹ / ₂	2 ¹ / ₄	5 ⁷ / ₈	3 ⁷ / ₁₆	7 ¹⁵ / ₁₆	7 ³ / ₈	
10	1 ³ / ₄	1 ¹ / ₂ -12	1 ¹ / ₄ -12	2	2.374	3 ³ / ₄	1 ¹ / ₂	1 ¹¹ / ₁₆	4	3 ³ / ₈	1 ¹ / ₈	1 ⁷ / ₈	6 ¹ / ₄	3 ¹ / ₈	8 ¹⁵ / ₁₆	8 ¹ / ₄	
	2	1 ³ / ₄ -12	1 ¹ / ₂ -12	2 ¹ / ₄	2.624	7 ⁷ / ₈	1 ¹¹ / ₁₆	1 ¹⁵ / ₁₆	4	3 ³ / ₈	1 ¹ / ₄	2	6 ³ / ₈	3 ¹ / ₄	9 ¹ / ₁₆	8 ³ / ₈	
	2 ¹ / ₂	2 ¹ / ₄ -12	1 ⁷ / ₈ -12	3	3.124	1	2 ¹ / ₁₆	2 ³ / ₈	4	1 ¹ / ₂	1 ¹ / ₂	2 ¹ / ₄	6 ⁵ / ₈	3 ¹ / ₂	9 ⁵ / ₁₆	8 ⁵ / ₈	
	3	2 ³ / ₄ -12	2 ¹ / ₄ -12	3 ¹ / ₂	3.749	1	2 ⁵ / ₈	2 ⁷ / ₈	5 ¹ / ₂	1 ¹ / ₂	1 ¹ / ₂	2 ¹ / ₄	6 ⁵ / ₈	3 ¹ / ₂	9 ⁵ / ₁₆	8 ⁵ / ₈	
	3 ¹ / ₂	3 ¹ / ₄ -12	2 ¹ / ₂ -12	3 ¹ / ₂	4.249	1	3	3 ³ / ₈	5 ¹ / ₂	1 ¹ / ₂	1 ¹ / ₂	2 ¹ / ₄	6 ⁵ / ₈	3 ¹ / ₂	9 ⁵ / ₁₆	8 ⁵ / ₈	
	4	3 ³ / ₄ -12	3-12	4	4.749	1	3 ³ / ₈	3 ⁷ / ₈	5 ¹ / ₂	1 ¹ / ₂	1 ¹ / ₂	2 ¹ / ₄	6 ⁵ / ₈	3 ¹ / ₂	9 ⁵ / ₁₆	8 ⁵ / ₈	
	4 ¹ / ₂	4 ¹ / ₄ -12	3 ¹ / ₄ -12	4 ¹ / ₂	5.249	1	3 ⁷ / ₈	4 ³ / ₈	7	1 ¹ / ₂	1 ¹ / ₂	2 ¹ / ₄	6 ⁵ / ₈	3 ¹ / ₂	9 ⁵ / ₁₆	8 ⁵ / ₈	
	5	4 ³ / ₄ -12	3 ¹ / ₂ -12	5	5.749	1	4 ¹ / ₄	4 ⁷ / ₈	7	1 ¹ / ₂	1 ¹ / ₂	2 ¹ / ₄	6 ⁵ / ₈	3 ¹ / ₂	9 ⁵ / ₁₆	8 ⁵ / ₈	
5 ¹ / ₂	5 ¹ / ₄ -12	4-12	5 ¹ / ₂	6.249	1	4 ⁵ / ₈	5 ³ / ₈	7	1 ¹ / ₂	1 ¹ / ₂	2 ¹ / ₄	6 ⁵ / ₈	3 ¹ / ₂	9 ⁵ / ₁₆	8 ⁵ / ₈		
12	2	1 ³ / ₄ -12	1 ¹ / ₂ -12	2 ¹ / ₄	2.624	7 ⁷ / ₈	1 ¹¹ / ₁₆	1 ¹⁵ / ₁₆	4	3 ³ / ₈	1 ¹ / ₄	2	6 ⁷ / ₈	3 ¹ / ₄	9 ⁹ / ₁₆	8 ⁷ / ₈	
	2 ¹ / ₂	2 ¹ / ₄ -12	1 ⁷ / ₈ -12	3	3.124	1	2 ¹ / ₁₆	2 ³ / ₈	4	1 ¹ / ₂	1 ¹ / ₂	2 ¹ / ₄	7 ¹ / ₈	3 ¹ / ₂	9 ¹³ / ₁₆	9 ¹ / ₈	
	3	2 ³ / ₄ -12	2 ¹ / ₄ -12	3 ¹ / ₂	3.749	1	2 ⁵ / ₈	2 ⁷ / ₈	5 ¹ / ₂	1 ¹ / ₂	1 ¹ / ₂	2 ¹ / ₄	7 ¹ / ₈	3 ¹ / ₂	9 ¹³ / ₁₆	9 ¹ / ₈	
	3 ¹ / ₂	3 ¹ / ₄ -12	2 ¹ / ₂ -12	3 ¹ / ₂	4.249	1	3	3 ³ / ₈	5 ¹ / ₂	1 ¹ / ₂	1 ¹ / ₂	2 ¹ / ₄	7 ¹ / ₈	3 ¹ / ₂	9 ¹³ / ₁₆	9 ¹ / ₈	
	4	3 ³ / ₄ -12	3-12	4	4.749	1	3 ³ / ₈	3 ⁷ / ₈	5 ¹ / ₂	1 ¹ / ₂	1 ¹ / ₂	2 ¹ / ₄	7 ¹ / ₈	3 ¹ / ₂	9 ¹³ / ₁₆	9 ¹ / ₈	
	4 ¹ / ₂	4 ¹ / ₄ -12	3 ¹ / ₄ -12	4 ¹ / ₂	5.249	1	3 ⁷ / ₈	4 ³ / ₈	7	1 ¹ / ₂	1 ¹ / ₂	2 ¹ / ₄	7 ¹ / ₈	3 ¹ / ₂	9 ¹³ / ₁₆	9 ¹ / ₈	
	5	4 ³ / ₄ -12	3 ¹ / ₂ -12	5	5.749	1	4 ¹ / ₄	4 ⁷ / ₈	7	1 ¹ / ₂	1 ¹ / ₂	2 ¹ / ₄	7 ¹ / ₈	3 ¹ / ₂	9 ¹³ / ₁₆	9 ¹ / ₈	
	5 ¹ / ₂	5 ¹ / ₄ -12	4-12	5 ¹ / ₂	6.249	1	4 ⁵ / ₈	5 ³ / ₈	7	1 ¹ / ₂	1 ¹ / ₂	2 ¹ / ₄	7 ¹ / ₈	3 ¹ / ₂	9 ¹³ / ₁₆	9 ¹ / ₈	
14	2 ¹ / ₂	2 ¹ / ₄ -12	1 ⁷ / ₈ -12	3	3.124	1	2 ¹ / ₁₆	2 ³ / ₈	4	1 ¹ / ₂	1 ¹ / ₂	2 ¹ / ₄	8 ¹ / ₈	3 ¹³ / ₁₆	11 ¹ / ₈	10 ³ / ₈	
	3	2 ³ / ₄ -12	2 ¹ / ₄ -12	3 ¹ / ₂	3.749	1	2 ⁵ / ₈	2 ⁷ / ₈	5 ¹ / ₂	1 ¹ / ₂	1 ¹ / ₂	2 ¹ / ₄	8 ¹ / ₈	3 ¹³ / ₁₆	11 ¹ / ₈	10 ³ / ₈	
	3 ¹ / ₂	3 ¹ / ₄ -12	2 ¹ / ₂ -12	3 ¹ / ₂	4.249	1	3	3 ³ / ₈	5 ¹ / ₂	1 ¹ / ₂	1 ¹ / ₂	2 ¹ / ₄	8 ¹ / ₈	3 ¹³ / ₁₆	11 ¹ / ₈	10 ³ / ₈	
	4	3 ³ / ₄ -12	3-12	4	4.749	1	3 ³ / ₈	3 ⁷ / ₈	5 ¹ / ₂	1 ¹ / ₂	1 ¹ / ₂	2 ¹ / ₄	8 ¹ / ₈	3 ¹³ / ₁₆	11 ¹ / ₈	10 ³ / ₈	
	4 ¹ / ₂	4 ¹ / ₄ -12	3 ¹ / ₄ -12	4 ¹ / ₂	5.249	1	3 ⁷ / ₈	4 ³ / ₈	7	1 ¹ / ₂	1 ¹ / ₂	2 ¹ / ₄	8 ¹ / ₈	3 ¹³ / ₁₆	11 ¹ / ₈	10 ³ / ₈	
	5	4 ³ / ₄ -12	3 ¹ / ₂ -12	5	5.749	1	4 ¹ / ₄	4 ⁷ / ₈	7	1 ¹ / ₂	1 ¹ / ₂	2 ¹ / ₄	8 ¹ / ₈	3 ¹³ / ₁₆	11 ¹ / ₈	10 ³ / ₈	
5 ¹ / ₂	5 ¹ / ₄ -12	4-12	5 ¹ / ₂	6.249	1	4 ⁵ / ₈	5 ³ / ₈	7	1 ¹ / ₂	1 ¹ / ₂	2 ¹ / ₄	8 ¹ / ₈	3 ¹³ / ₁₆	11 ¹ / ₈	10 ³ / ₈		

Miller AV Series Heavy-Duty Air Cylinders

Head Trunnion Mount and Cap Trunnion Mount – 7" to 14" Bore Sizes
Intermediate Trunnion Mount – 8" to 14" Bore Sizes

Head Trunnion Mount Model 81 7" - 14" Bore

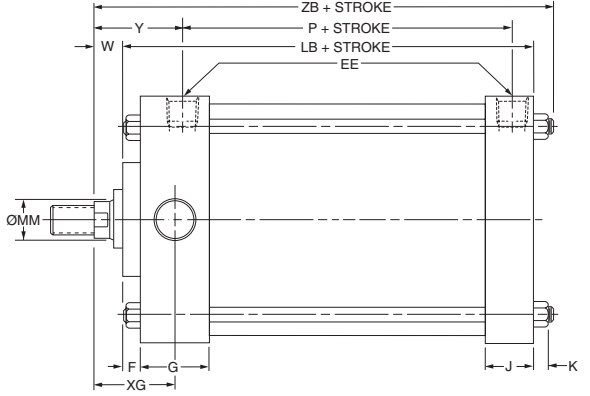
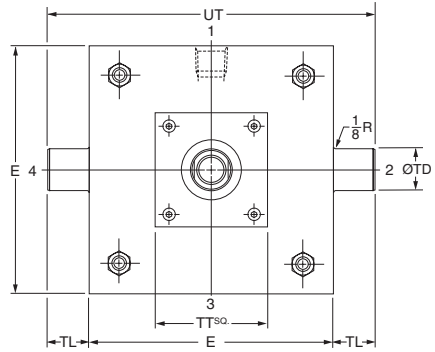
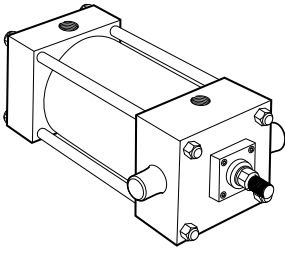

Cap Trunnion Mount Model 82 7" - 14" Bore

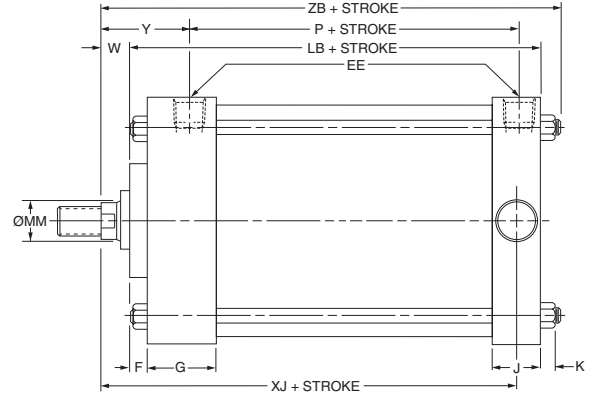
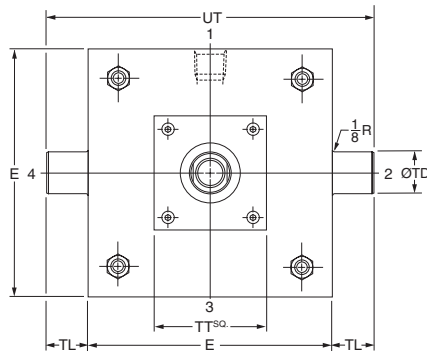
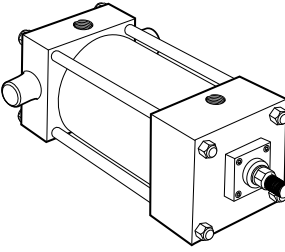

Intermediate Trunnion Mount Model 89 8" - 14" Bore

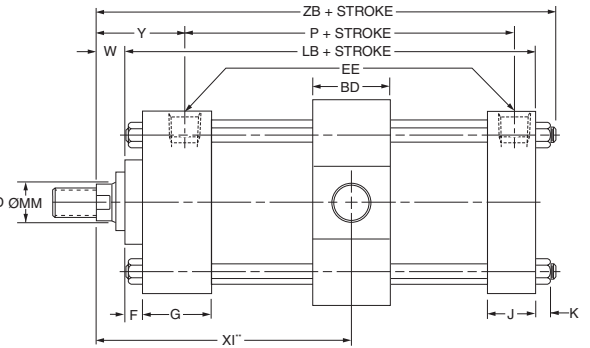
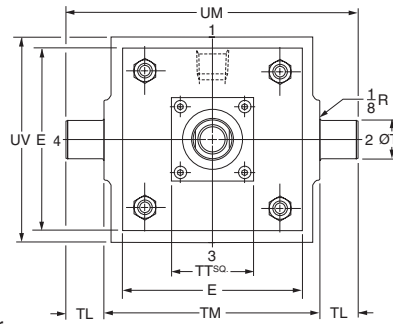
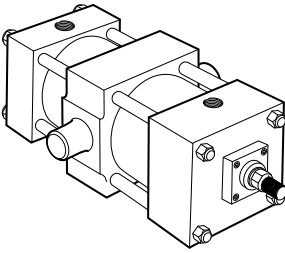

**Dimension "XI" to be specified by customer.

Rod End Dimensions — see table 2

Thread Style 2 Small Male

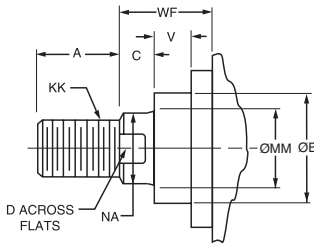

Thread Style 4 Short Female

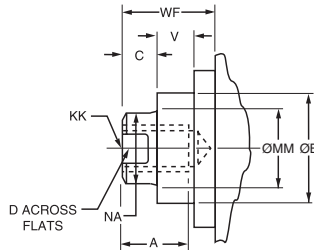

Thread Style 5 Intermediate Male

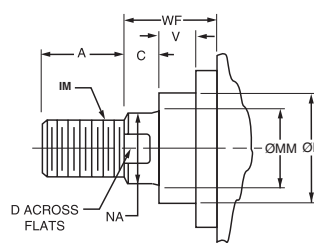

"Special" Thread Style X

Special thread, extension, rod eye, blank, etc., are also available.

To order, specify "Style X" and give desired dimensions for KK, A and WF. If otherwise special, furnish dimensioned sketch.

A high strength rod end stud is supplied on thread style 2 through 2" diameter rods and on thread style 5 through 1 3/8" diameter rods. Larger sizes or special rod ends are cut threads. Style 2 rod ends are recommended where the workpiece is secured against the rod shoulder. When the workpiece is not shouldered, style 2 rod ends

are recommended through 2" piston rod diameters and style 5 rod ends are recommended on larger diameters. Use style 4 for applications where female rod end threads are required. If rod end is not specified, style 2 will be supplied.

Miller AV Series Heavy-Duty Air Cylinders

Head Trunnion Mount and Cap Trunnion Mount – 7" to 14" Bore Sizes
Intermediate Trunnion Mount – 8" to 14" Bore Sizes

Table 1—Envelope and Mounting Dimensions

Bore	BD	E	EE NPTF	F	G	J	K	TD Ø + .000 -.001	TL	TM	UT	UM	UV	Add Stroke	
														LB	P
7	—	7 ¹ / ₂	³ / ₄	³ / ₄	2	1 ¹ / ₂	⁹ / ₁₆	1.375	1 ³ / ₈	—	10 ¹ / ₄	—	—	5 ⁷ / ₈	3 ¹ / ₄
8	2 ¹ / ₂	8 ¹ / ₂	³ / ₄	³ / ₄	2	1 ¹ / ₂	⁴⁹ / ₆₄	1.375	1 ³ / ₈	9 ³ / ₄	11 ¹ / ₄	12 ¹ / ₂	9 ¹ / ₂	5 ⁷ / ₈	3 ¹ / ₄
10	3	10 ⁵ / ₈	1	³ / ₄	2 ¹ / ₄	2	⁴⁹ / ₆₄	1.750	1 ³ / ₄	12	14 ¹ / ₈	15 ¹ / ₂	11 ³ / ₄	7 ¹ / ₈	4 ¹ / ₈
12	3	12 ³ / ₄	1	³ / ₄	2 ¹ / ₄	2	⁵⁷ / ₆₄	1.750	1 ³ / ₄	14	16 ¹ / ₄	17 ¹ / ₂	13 ³ / ₄	7 ⁵ / ₈	4 ⁵ / ₈
14	3 ¹ / ₂	14 ³ / ₄	1 ¹ / ₄	³ / ₄	2 ³ / ₄	2 ¹ / ₄	1	2.000	2	16 ¹ / ₄	18 ³ / ₄	20 ¹ / ₄	16	8 ⁷ / ₈	5 ¹ / ₂

Table 2—Rod End Dimensions and Envelope Dimensions Affected By Rod Size

Bore	MM Rod Ø	Thread		Rod End Dimensions and Envelope Dimensions Affected By Rod Size														Add Stroke	
		Style 5 IM	Style 2 & 4 KK	A	B Ø + .000 -.002	C	D	NA	TT	V	W	XG	XI** (Min.)	Y	XJ	ZB			
7	1 ³ / ₈	1 ¹ / ₂ -12	1-14	1 ⁵ / ₈	1.999	⁵ / ₈	1 ¹ / ₈	1 ⁵ / ₁₆	4	¹ / ₄	⁷ / ₈	2 ⁵ / ₈	—	2 ¹³ / ₁₆	6	7 ⁵ / ₁₆			
	1 ³ / ₄	1 ¹ / ₂ -12	1 ¹ / ₄ -12	2	2.374	³ / ₄	1 ¹ / ₂	1 ¹¹ / ₁₆	4	³ / ₈	1 ¹ / ₈	2 ⁷ / ₈	—	3 ¹ / ₁₆	6 ¹ / ₄	7 ⁹ / ₁₆			
	2	1 ³ / ₄ -12	1 ¹ / ₂ -12	2 ¹ / ₄	2.624	⁷ / ₈	1 ¹¹ / ₁₆	1 ¹⁵ / ₁₆	4	³ / ₈	1 ¹ / ₄	3	—	3 ³ / ₁₆	6 ³ / ₈	7 ¹¹ / ₁₆			
8	1 ³ / ₈	1 ¹ / ₂ -12	1-14	1 ⁵ / ₈	1.999	⁵ / ₈	1 ¹ / ₈	1 ⁵ / ₁₆	4	¹ / ₄	⁷ / ₈	2 ⁵ / ₈	4 ¹⁵ / ₁₆	2 ¹³ / ₁₆	6	7 ⁵ / ₁₆			
	5 ¹ / ₂	5 ¹ / ₄ -12	4-12	5 ¹ / ₂	6.249	1	4 ⁵ / ₈	5 ³ / ₈	7	¹ / ₂	1 ¹ / ₂	3 ¹ / ₄	5 ⁹ / ₁₆	3 ⁷ / ₁₆	6 ⁵ / ₈	7 ¹⁵ / ₁₆			
	1 ³ / ₄	1 ¹ / ₂ -12	1 ¹ / ₄ -12	2	2.374	³ / ₄	1 ¹ / ₂	1 ¹¹ / ₁₆	4	³ / ₈	1 ¹ / ₈	2 ⁷ / ₈	5 ³ / ₁₆	3 ¹ / ₁₆	6 ¹ / ₄	7 ⁹ / ₁₆			
	2	1 ³ / ₄ -12	1 ¹ / ₂ -12	2 ¹ / ₄	2.624	⁷ / ₈	1 ¹¹ / ₁₆	1 ¹⁵ / ₁₆	4	³ / ₈	1 ¹ / ₄	3	5 ⁹ / ₁₆	3 ³ / ₁₆	6 ³ / ₈	7 ¹¹ / ₁₆			
	2 ¹ / ₂	2 ¹ / ₄ -12	1 ⁷ / ₈ -12	3	3.124	1	2 ¹ / ₁₆	2 ³ / ₈	4	¹ / ₂	1 ¹ / ₂	3 ¹ / ₄	5 ⁹ / ₁₆	3 ⁷ / ₁₆	6 ⁵ / ₈	7 ¹⁵ / ₁₆			
	3	2 ³ / ₄ -12	2 ¹ / ₄ -12	3 ¹ / ₂	3.749	1	2 ⁵ / ₈	2 ⁷ / ₈	5 ¹ / ₂	¹ / ₂	1 ¹ / ₂	3 ¹ / ₄	5 ⁹ / ₁₆	3 ⁷ / ₁₆	6 ⁵ / ₈	7 ¹⁵ / ₁₆			
	3 ¹ / ₂	3 ¹ / ₄ -12	2 ¹ / ₂ -12	3 ¹ / ₂	4.249	1	3	3 ³ / ₈	5 ¹ / ₂	¹ / ₂	1 ¹ / ₂	3 ¹ / ₄	5 ⁹ / ₁₆	3 ⁷ / ₁₆	6 ⁵ / ₈	7 ¹⁵ / ₁₆			
	4	3 ³ / ₄ -12	3-12	4	4.749	1	3 ³ / ₈	3 ⁷ / ₈	5 ¹ / ₂	¹ / ₂	1 ¹ / ₂	3 ¹ / ₄	5 ⁹ / ₁₆	3 ⁷ / ₁₆	6 ⁵ / ₈	7 ¹⁵ / ₁₆			
	4 ¹ / ₂	4 ¹ / ₄ -12	3 ¹ / ₄ -12	4 ¹ / ₂	5.249	1	3 ⁷ / ₈	4 ³ / ₈	7	¹ / ₂	1 ¹ / ₂	3 ¹ / ₄	5 ⁹ / ₁₆	3 ⁷ / ₁₆	6 ⁵ / ₈	7 ¹⁵ / ₁₆			
10	1 ³ / ₄	1 ¹ / ₂ -12	1 ¹ / ₄ -12	2	2.374	³ / ₄	1 ¹ / ₂	1 ¹¹ / ₁₆	4	³ / ₈	1 ¹ / ₈	3	5 ¹¹ / ₁₆	3 ¹ / ₈	7 ¹ / ₄	8 ¹⁵ / ₁₆			
	2	1 ³ / ₄ -12	1 ¹ / ₂ -12	2 ¹ / ₄	2.624	⁷ / ₈	1 ¹¹ / ₁₆	1 ¹⁵ / ₁₆	4	³ / ₈	1 ¹ / ₄	3 ¹ / ₈	5 ¹³ / ₁₆	3 ¹ / ₄	7 ³ / ₈	9 ¹ / ₁₆			
	2 ¹ / ₂	2 ¹ / ₄ -12	1 ⁷ / ₈ -12	3	3.124	1	2 ¹ / ₁₆	2 ³ / ₈	4	¹ / ₂	1 ¹ / ₂	3 ³ / ₈	6 ¹ / ₁₆	3 ¹ / ₂	7 ⁵ / ₈	9 ⁵ / ₁₆			
	3	2 ³ / ₄ -12	2 ¹ / ₄ -12	3 ¹ / ₂	3.749	1	2 ⁵ / ₈	2 ⁷ / ₈	5 ¹ / ₂	¹ / ₂	1 ¹ / ₂	3 ³ / ₈	6 ¹ / ₁₆	3 ¹ / ₂	7 ⁵ / ₈	9 ⁵ / ₁₆			
	3 ¹ / ₂	3 ¹ / ₄ -12	2 ¹ / ₂ -12	3 ¹ / ₂	4.249	1	3	3 ³ / ₈	5 ¹ / ₂	¹ / ₂	1 ¹ / ₂	3 ³ / ₈	6 ¹ / ₁₆	3 ¹ / ₂	7 ⁵ / ₈	9 ⁵ / ₁₆			
	4	3 ³ / ₄ -12	3-12	4	4.749	1	3 ³ / ₈	3 ⁷ / ₈	5 ¹ / ₂	¹ / ₂	1 ¹ / ₂	3 ³ / ₈	6 ¹ / ₁₆	3 ¹ / ₂	7 ⁵ / ₈	9 ⁵ / ₁₆			
	4 ¹ / ₂	4 ¹ / ₄ -12	3 ¹ / ₄ -12	4 ¹ / ₂	5.249	1	3 ⁷ / ₈	4 ³ / ₈	7	¹ / ₂	1 ¹ / ₂	3 ³ / ₈	6 ¹ / ₁₆	3 ¹ / ₂	7 ⁵ / ₈	9 ⁵ / ₁₆			
	5	4 ³ / ₄ -12	3 ¹ / ₂ -12	5	5.749	1	4 ¹ / ₄	4 ⁷ / ₈	7	¹ / ₂	1 ¹ / ₂	3 ³ / ₈	6 ¹ / ₁₆	3 ¹ / ₂	7 ⁵ / ₈	9 ⁵ / ₁₆			
12	5 ¹ / ₂	5 ¹ / ₄ -12	4-12	5 ¹ / ₂	6.249	1	4 ⁵ / ₈	5 ³ / ₈	7	¹ / ₂	1 ¹ / ₂	3 ³ / ₈	6 ¹ / ₁₆	3 ¹ / ₂	7 ⁵ / ₈	9 ⁵ / ₁₆			
	2	1 ³ / ₄ -12	1 ¹ / ₂ -12	2 ¹ / ₄	2.624	⁷ / ₈	1 ¹¹ / ₁₆	1 ¹⁵ / ₁₆	4	³ / ₈	1 ¹ / ₄	3 ¹ / ₈	5 ¹³ / ₁₆	3 ¹ / ₄	7 ⁷ / ₈	9 ⁹ / ₁₆			
	2 ¹ / ₂	2 ¹ / ₄ -12	1 ⁷ / ₈ -12	3	3.124	1	2 ¹ / ₁₆	2 ³ / ₈	4	¹ / ₂	1 ¹ / ₂	3 ³ / ₈	6 ¹ / ₁₆	3 ¹ / ₂	8 ¹ / ₈	9 ¹³ / ₁₆			
	3	2 ³ / ₄ -12	2 ¹ / ₄ -12	3 ¹ / ₂	3.749	1	2 ⁵ / ₈	2 ⁷ / ₈	5 ¹ / ₂	¹ / ₂	1 ¹ / ₂	3 ³ / ₈	6 ¹ / ₁₆	3 ¹ / ₂	8 ¹ / ₈	9 ¹³ / ₁₆			
	3 ¹ / ₂	3 ¹ / ₄ -12	2 ¹ / ₂ -12	3 ¹ / ₂	4.249	1	3	3 ³ / ₈	5 ¹ / ₂	¹ / ₂	1 ¹ / ₂	3 ³ / ₈	6 ¹ / ₁₆	3 ¹ / ₂	8 ¹ / ₈	9 ¹³ / ₁₆			
	4	3 ³ / ₄ -12	3-12	4	4.749	1	3 ³ / ₈	3 ⁷ / ₈	5 ¹ / ₂	¹ / ₂	1 ¹ / ₂	3 ³ / ₈	6 ¹ / ₁₆	3 ¹ / ₂	8 ¹ / ₈	9 ¹³ / ₁₆			
	4 ¹ / ₂	4 ¹ / ₄ -12	3 ¹ / ₄ -12	4 ¹ / ₂	5.249	1	3 ⁷ / ₈	4 ³ / ₈	7	¹ / ₂	1 ¹ / ₂	3 ³ / ₈	6 ¹ / ₁₆	3 ¹ / ₂	8 ¹ / ₈	9 ¹³ / ₁₆			
14	5	4 ³ / ₄ -12	3 ¹ / ₂ -12	5	5.749	1	4 ¹ / ₄	4 ⁷ / ₈	7	¹ / ₂	1 ¹ / ₂	3 ³ / ₈	6 ¹ / ₁₆	3 ¹ / ₂	8 ¹ / ₈	9 ¹³ / ₁₆			
	5 ¹ / ₂	5 ¹ / ₄ -12	4-12	5 ¹ / ₂	6.249	1	4 ⁵ / ₈	5 ³ / ₈	7	¹ / ₂	1 ¹ / ₂	3 ³ / ₈	6 ¹ / ₁₆	3 ¹ / ₂	8 ¹ / ₈	9 ¹³ / ₁₆			
	2 ¹ / ₂	2 ¹ / ₄ -12	1 ⁷ / ₈ -12	3	3.124	1	2 ¹ / ₁₆	2 ³ / ₈	4	¹ / ₂	1 ¹ / ₂	3 ³ / ₈	6 ¹³ / ₁₆	3 ¹³ / ₁₆	9 ¹ / ₄	11 ¹ / ₈			
	3	2 ³ / ₄ -12	2 ¹ / ₄ -12	3 ¹ / ₂	3.749	1	2 ⁵ / ₈	2 ⁷ / ₈	5 ¹ / ₂	¹ / ₂	1 ¹ / ₂	3 ⁵ / ₈	6 ¹³ / ₁₆	3 ¹³ / ₁₆	9 ¹ / ₄	11 ¹ / ₈			
	3 ¹ / ₂	3 ¹ / ₄ -12	2 ¹ / ₂ -12	3 ¹ / ₂	4.249	1	3	3 ³ / ₈	5 ¹ / ₂	¹ / ₂	1 ¹ / ₂	3 ⁵ / ₈	6 ¹³ / ₁₆	3 ¹³ / ₁₆	9 ¹ / ₄	11 ¹ / ₈			
	4	3 ³ / ₄ -12	3-12	4	4.749	1	3 ³ / ₈	3 ⁷ / ₈	5 ¹ / ₂	¹ / ₂	1 ¹ / ₂	3 ⁵ / ₈	6 ¹³ / ₁₆	3 ¹³ / ₁₆	9 ¹ / ₄	11 ¹ / ₈			

**Dimension "XI" to be specified by customer.

Miller AV Series Heavy-Duty Air Cylinders

Cap Fixed Clevis Mount
Tie Rods Extended Mountings
7" to 14" Bore Sizes

Cap Fixed Clevis Mount Model 84 7" - 14" Bore

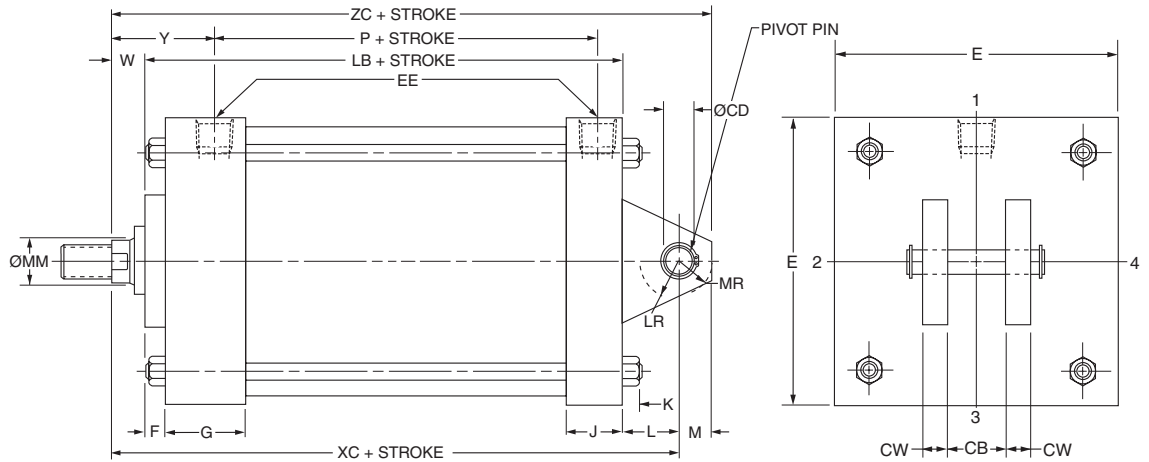
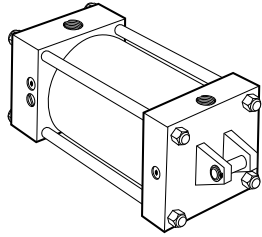

Tie Rods Extended Mountings Model 53 7" - 14" Bore

Model 53 Head Tie Rods Extended, Illustrated. Model 52 Cap Tie Rods Extended; and Model 51, Both Ends Tie Rods Extended are also available. All Tie Rod Models can be dimensioned from Model 53 drawing below.

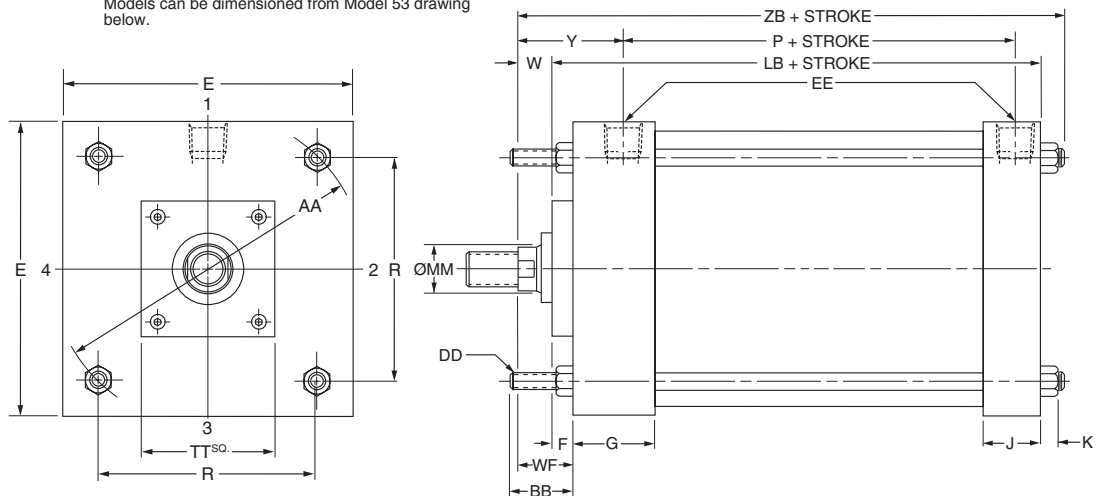
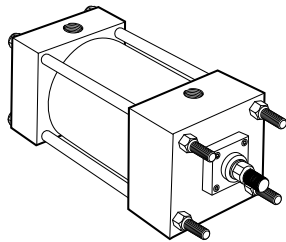

Models 51 and 53 not offered in 8" bore, rod diameters 4 1/2", 5" and 5 1/2".

Rod End Dimensions — see table 2

Thread Style 2 Small Male

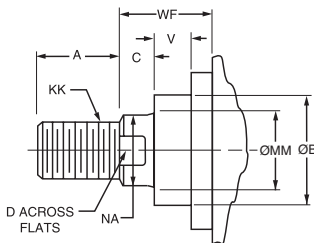

A high strength rod end stud is supplied on thread style 2 through 2" diameter rods and on thread style 5 through 1 3/8" diameter rods. Larger sizes or special rod ends are cut threads. Style 2 rod ends are recommended where the workpiece is secured against the rod shoulder. When the workpiece is not shouldered, style 2 rod ends

Thread Style 4 Short Female

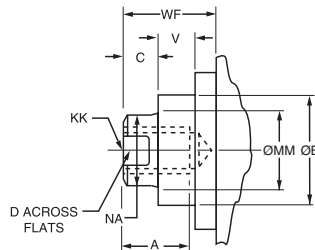

are recommended through 2" piston rod diameters and style 5 rod ends are recommended on larger diameters. Use style 4 for applications where female rod end threads are required. If rod end is not specified, style 2 will be supplied.

Thread Style 5 Intermediate Male

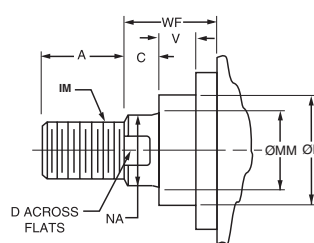

"Special" Thread Style X

Special thread, extension, rod eye, blank, etc., are also available.

To order, specify "Style X" and give desired dimensions for KK , A and WF . If otherwise special, furnish dimensioned sketch.

Miller AV Series Heavy-Duty Air Cylinders

Cap Fixed Clevis Mount
Tie Rods Extended Mountings
7" to 14" Bore Sizes

Table 1—Envelope and Mounting Dimensions

Bore	AA	BB	CB	CD ^{Ø*} +0.000 -0.001	CW	DD	E	EE NPTF	F	G	J	K	L	LR	M	MR	R	Add Stroke	
																		LB	P
7	8.1	2 ⁵ / ₁₆	1 ¹ / ₂	1.000	³ / ₄	⁵ / ₈ -18	7 ¹ / ₂	³ / ₄	³ / ₄	2	1 ¹ / ₂	⁹ / ₁₆	1 ¹ / ₂	1 ¹ / ₄	1	1 ³ / ₁₆	5.73	5 ⁷ / ₈	3 ¹ / ₄
8	9.1	2 ⁵ / ₁₆	1 ¹ / ₂	1.000	³ / ₄	⁵ / ₈ -18	8 ¹ / ₂	³ / ₄	³ / ₄	2	1 ¹ / ₂	⁹ / ₁₆	1 ¹ / ₂	1 ¹ / ₄	1	1 ³ / ₁₆	6.44	5 ⁷ / ₈	3 ¹ / ₄
10	11.2	2 ¹¹ / ₁₆	2	1.375	1	³ / ₄ -16	10 ⁹ / ₈	1	³ / ₄	2 ¹ / ₄	2	¹¹ / ₁₆	2 ¹ / ₈	1 ⁷ / ₈	1 ³ / ₈	1 ⁵ / ₈	7.92	7 ¹ / ₈	4 ¹ / ₈
12	13.3	2 ¹¹ / ₁₆	2 ¹ / ₂	1.750	1 ¹ / ₄	³ / ₄ -16	12 ³ / ₄	1	³ / ₄	2 ¹ / ₄	2	¹¹ / ₁₆	2 ¹ / ₄	2 ¹ / ₈	1 ³ / ₄	2 ¹ / ₈	9.40	7 ⁵ / ₈	4 ⁵ / ₈
14	15.4	3 ³ / ₁₆	2 ¹ / ₂	2.000	1 ¹ / ₄	⁷ / ₈ -14	14 ³ / ₄	1 ¹ / ₄	³ / ₄	2 ³ / ₄	2 ¹ / ₄	³ / ₄	2 ¹ / ₂	2 ³ / ₈	2	2 ³ / ₈	10.90	8 ⁷ / ₈	5 ¹ / ₂

* CD is pin diameter.

Table 2—Rod End Dimensions and Envelope Dimensions Affected By Rod Size

Bore	MM Rod Ø	Thread		Rod End Dimensions and Envelope Dimensions Affected By Rod Size														Add Stroke	
		Style 5 IM	Style 2 & 4 KK	A	B Ø +0.000 -0.02	C	D	NA	TT	V	W	WF	XC	Y	ZB	ZC			
7	1 ³ / ₈	1 ¹ / ₄ -12	1-14	1 ⁵ / ₈	1.999	⁵ / ₈	1 ¹ / ₈	1 ⁵ / ₁₆	4	¹ / ₄	⁷ / ₈	1 ⁵ / ₈	8 ¹ / ₄	2 ¹³ / ₁₆	7 ⁵ / ₁₆	9 ¹ / ₄			
	1 ³ / ₄	1 ¹ / ₂ -12	1 ¹ / ₄ -12	2	2.374	³ / ₄	1 ¹ / ₂	1 ¹¹ / ₁₆	4	³ / ₈	1 ¹ / ₈	1 ⁷ / ₈	8 ¹ / ₂	3 ¹ / ₁₆	7 ⁹ / ₁₆	9 ¹ / ₂			
	2	1 ³ / ₄ -12	1 ¹ / ₂ -12	2 ¹ / ₄	2.624	⁷ / ₈	1 ¹¹ / ₁₆	1 ¹⁵ / ₁₆	4	³ / ₈	1 ¹ / ₄	2	8 ⁵ / ₈	3 ³ / ₁₆	7 ¹¹ / ₁₆	9 ⁵ / ₈			
8	1 ³ / ₈	1 ¹ / ₄ -12	1-14	1 ⁵ / ₈	1.999	⁵ / ₈	1 ¹ / ₈	1 ⁵ / ₁₆	4	¹ / ₄	⁷ / ₈	1 ⁵ / ₈	8 ¹ / ₄	2 ¹³ / ₁₆	7 ⁵ / ₁₆	9 ¹ / ₄			
	5 ¹ / ₂	5 ¹ / ₄ -12	4-12	5 ¹ / ₂	6.249	1	4 ⁵ / ₈	5 ³ / ₈	7	¹ / ₂	1 ¹ / ₂	2 ¹ / ₄	8 ⁷ / ₈	3 ⁷ / ₁₆	7 ¹⁵ / ₁₆	9 ⁷ / ₈			
	1 ³ / ₄	1 ¹ / ₂ -12	1 ¹ / ₄ -12	2	2.374	³ / ₄	1 ¹ / ₂	1 ¹¹ / ₁₆	4	³ / ₈	1 ¹ / ₈	1 ⁷ / ₈	8 ¹ / ₂	3 ¹ / ₁₆	7 ⁹ / ₁₆	9 ¹ / ₂			
	2	1 ³ / ₄ -12	1 ¹ / ₂ -12	2 ¹ / ₄	2.624	⁷ / ₈	1 ¹¹ / ₁₆	1 ¹⁵ / ₁₆	4	³ / ₈	1 ¹ / ₄	2	8 ⁵ / ₈	3 ³ / ₁₆	7 ¹¹ / ₁₆	9 ⁵ / ₈			
	2 ¹ / ₂	2 ¹ / ₄ -12	1 ⁷ / ₈ -12	3	3.124	1	2 ¹ / ₁₆	2 ³ / ₈	4	¹ / ₂	1 ¹ / ₂	2 ¹ / ₄	8 ⁷ / ₈	3 ⁷ / ₁₆	7 ¹⁵ / ₁₆	9 ⁷ / ₈			
	3	2 ³ / ₄ -12	2 ¹ / ₄ -12	3 ¹ / ₂	3.749	1	2 ⁵ / ₈	2 ⁷ / ₈	5 ¹ / ₂	¹ / ₂	1 ¹ / ₂	2 ¹ / ₄	8 ⁷ / ₈	3 ⁷ / ₁₆	7 ¹⁵ / ₁₆	9 ⁷ / ₈			
	3 ¹ / ₂	3 ¹ / ₄ -12	2 ¹ / ₂ -12	3 ¹ / ₂	4.249	1	3	3 ³ / ₈	5 ¹ / ₂	¹ / ₂	1 ¹ / ₂	2 ¹ / ₄	8 ⁷ / ₈	3 ⁷ / ₁₆	7 ¹⁵ / ₁₆	9 ⁷ / ₈			
	4	3 ³ / ₄ -12	3-12	4	4.749	1	3 ³ / ₈	3 ⁷ / ₈	5 ¹ / ₂	¹ / ₂	1 ¹ / ₂	2 ¹ / ₄	8 ⁷ / ₈	3 ⁷ / ₁₆	7 ¹⁵ / ₁₆	9 ⁷ / ₈			
4 ¹ / ₂	4 ¹ / ₄ -12	3 ¹ / ₄ -12	4 ¹ / ₂	5.249	1	3 ⁷ / ₈	4 ³ / ₈	7	¹ / ₂	1 ¹ / ₂	2 ¹ / ₄	8 ⁷ / ₈	3 ⁷ / ₁₆	7 ¹⁵ / ₁₆	9 ⁷ / ₈				
5	4 ³ / ₄ -12	3 ¹ / ₂ -12	5	5.749	1	4 ¹ / ₄	4 ⁷ / ₈	7	¹ / ₂	1 ¹ / ₂	2 ¹ / ₄	8 ⁷ / ₈	3 ⁷ / ₁₆	7 ¹⁵ / ₁₆	9 ⁷ / ₈				
10	1 ³ / ₄	1 ¹ / ₂ -12	1 ¹ / ₄ -12	2	2.374	³ / ₄	1 ¹ / ₂	1 ¹¹ / ₁₆	4	³ / ₈	1 ¹ / ₈	1 ⁷ / ₈	10 ³ / ₈	3 ¹ / ₈	8 ¹⁵ / ₁₆	11 ³ / ₄			
	2	1 ³ / ₄ -12	1 ¹ / ₂ -12	2 ¹ / ₄	2.624	⁷ / ₈	1 ¹¹ / ₁₆	1 ¹⁵ / ₁₆	4	³ / ₈	1 ¹ / ₄	2	10 ¹ / ₂	3 ¹ / ₄	9 ¹ / ₁₆	11 ⁷ / ₈			
	2 ¹ / ₂	2 ¹ / ₄ -12	1 ⁷ / ₈ -12	3	3.124	1	2 ¹ / ₁₆	2 ³ / ₈	4	¹ / ₂	1 ¹ / ₂	2 ¹ / ₄	10 ³ / ₄	3 ¹ / ₂	9 ⁵ / ₁₆	12 ¹ / ₈			
	3	2 ³ / ₄ -12	2 ¹ / ₄ -12	3 ¹ / ₂	3.749	1	2 ⁵ / ₈	2 ⁷ / ₈	5 ¹ / ₂	¹ / ₂	1 ¹ / ₂	2 ¹ / ₄	10 ³ / ₄	3 ¹ / ₂	9 ⁵ / ₁₆	12 ¹ / ₈			
	3 ¹ / ₂	3 ¹ / ₄ -12	2 ¹ / ₂ -12	3 ¹ / ₂	4.249	1	3	3 ³ / ₈	5 ¹ / ₂	¹ / ₂	1 ¹ / ₂	2 ¹ / ₄	10 ³ / ₄	3 ¹ / ₂	9 ⁵ / ₁₆	12 ¹ / ₈			
	4	3 ³ / ₄ -12	3-12	4	4.749	1	3 ³ / ₈	3 ⁷ / ₈	5 ¹ / ₂	¹ / ₂	1 ¹ / ₂	2 ¹ / ₄	10 ³ / ₄	3 ¹ / ₂	9 ⁵ / ₁₆	12 ¹ / ₈			
	4 ¹ / ₂	4 ¹ / ₄ -12	3 ¹ / ₄ -12	4 ¹ / ₂	5.249	1	3 ⁷ / ₈	4 ³ / ₈	7	¹ / ₂	1 ¹ / ₂	2 ¹ / ₄	10 ³ / ₄	3 ¹ / ₂	9 ⁵ / ₁₆	12 ¹ / ₈			
	5	4 ³ / ₄ -12	3 ¹ / ₂ -12	5	5.749	1	4 ¹ / ₄	4 ⁷ / ₈	7	¹ / ₂	1 ¹ / ₂	2 ¹ / ₄	10 ³ / ₄	3 ¹ / ₂	9 ⁵ / ₁₆	12 ¹ / ₈			
5 ¹ / ₂	5 ¹ / ₄ -12	4-12	5 ¹ / ₂	6.249	1	4 ⁵ / ₈	5 ³ / ₈	7	¹ / ₂	1 ¹ / ₂	2 ¹ / ₄	10 ³ / ₄	3 ¹ / ₂	9 ⁵ / ₁₆	12 ¹ / ₈				
12	2	1 ³ / ₄ -12	1 ¹ / ₂ -12	2 ¹ / ₄	2.624	⁷ / ₈	1 ¹¹ / ₁₆	1 ¹⁵ / ₁₆	4	³ / ₈	1 ¹ / ₄	2	11 ¹ / ₈	3 ¹ / ₄	9 ⁹ / ₁₆	12 ⁷ / ₈			
	2 ¹ / ₂	2 ¹ / ₄ -12	1 ⁷ / ₈ -12	3	3.124	1	2 ¹ / ₁₆	2 ³ / ₈	4	¹ / ₂	1 ¹ / ₂	2 ¹ / ₄	11 ³ / ₈	3 ¹ / ₂	9 ¹³ / ₁₆	13 ¹ / ₈			
	3	2 ³ / ₄ -12	2 ¹ / ₄ -12	3 ¹ / ₂	3.749	1	2 ⁵ / ₈	2 ⁷ / ₈	5 ¹ / ₂	¹ / ₂	1 ¹ / ₂	2 ¹ / ₄	11 ³ / ₈	3 ¹ / ₂	9 ¹³ / ₁₆	13 ¹ / ₈			
	3 ¹ / ₂	3 ¹ / ₄ -12	2 ¹ / ₂ -12	3 ¹ / ₂	4.249	1	3	3 ³ / ₈	5 ¹ / ₂	¹ / ₂	1 ¹ / ₂	2 ¹ / ₄	11 ³ / ₈	3 ¹ / ₂	9 ¹³ / ₁₆	13 ¹ / ₈			
	4	3 ³ / ₄ -12	3-12	4	4.749	1	3 ³ / ₈	3 ⁷ / ₈	5 ¹ / ₂	¹ / ₂	1 ¹ / ₂	2 ¹ / ₄	11 ³ / ₈	3 ¹ / ₂	9 ¹³ / ₁₆	13 ¹ / ₈			
	4 ¹ / ₂	4 ¹ / ₄ -12	3 ¹ / ₄ -12	4 ¹ / ₂	5.249	1	3 ⁷ / ₈	4 ³ / ₈	7	¹ / ₂	1 ¹ / ₂	2 ¹ / ₄	11 ³ / ₈	3 ¹ / ₂	9 ¹³ / ₁₆	13 ¹ / ₈			
	5	4 ³ / ₄ -12	3 ¹ / ₂ -12	5	5.749	1	4 ¹ / ₄	4 ⁷ / ₈	7	¹ / ₂	1 ¹ / ₂	2 ¹ / ₄	11 ³ / ₈	3 ¹ / ₂	9 ¹³ / ₁₆	13 ¹ / ₈			
5 ¹ / ₂	5 ¹ / ₄ -12	4-12	5 ¹ / ₂	6.249	1	4 ⁵ / ₈	5 ³ / ₈	7	¹ / ₂	1 ¹ / ₂	2 ¹ / ₄	11 ³ / ₈	3 ¹ / ₂	9 ¹³ / ₁₆	13 ¹ / ₈				
14	2 ¹ / ₂	2 ¹ / ₄ -12	1 ⁷ / ₈ -12	3	3.124	1	2 ¹ / ₁₆	2 ³ / ₈	4	¹ / ₂	1 ¹ / ₂	2 ¹ / ₄	12 ⁷ / ₈	3 ¹³ / ₁₆	11 ¹ / ₈	14 ⁷ / ₈			
	3	2 ³ / ₄ -12	2 ¹ / ₄ -12	3 ¹ / ₂	3.749	1	2 ⁵ / ₈	2 ⁷ / ₈	5 ¹ / ₂	¹ / ₂	1 ¹ / ₂	2 ¹ / ₄	12 ⁷ / ₈	3 ¹³ / ₁₆	11 ¹ / ₈	14 ⁷ / ₈			
	3 ¹ / ₂	3 ¹ / ₄ -12	2 ¹ / ₂ -12	3 ¹ / ₂	4.249	1	3	3 ³ / ₈	5 ¹ / ₂	¹ / ₂	1 ¹ / ₂	2 ¹ / ₄	12 ⁷ / ₈	3 ¹³ / ₁₆	11 ¹ / ₈	14 ⁷ / ₈			
	4	3 ³ / ₄ -12	3-12	4	4.749	1	3 ³ / ₈	3 ⁷ / ₈	5 ¹ / ₂	¹ / ₂	1 ¹ / ₂	2 ¹ / ₄	12 ⁷ / ₈	3 ¹³ / ₁₆	11 ¹ / ₈	14 ⁷ / ₈			
	4 ¹ / ₂	4 ¹ / ₄ -12	3 ¹ / ₄ -12	4 ¹ / ₂	5.249	1	3 ⁷ / ₈	4 ³ / ₈	7	¹ / ₂	1 ¹ / ₂	2 ¹ / ₄	12 ⁷ / ₈	3 ¹³ / ₁₆	11 ¹ / ₈	14 ⁷ / ₈			
	5	4 ³ / ₄ -12	3 ¹ / ₂ -12	5	5.749	1	4 ¹ / ₄	4											

Miller AV Series Heavy-Duty Air Cylinders

Double Rod End Cylinders
7" to 14" Bore Sizes

How to Use Double Rod Cylinder Dimension Drawings

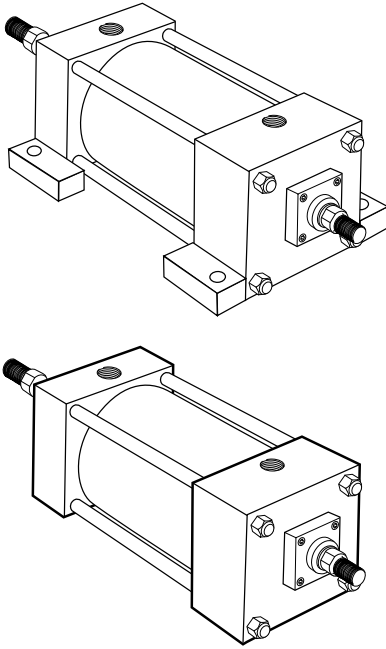

To determine dimensions for a double rod cylinder, first refer to the desired single rod mounting style cylinder shown on preceding pages of this catalog. After selecting necessary dimensions from that drawing, return to this page and supplement the single rod dimensions with those shown on the drawing and dimension table below. Note that double rod cylinders have a head (Dim. G) at both ends and that dimension LD replaces LB. The double rod dimensions differ from, or are in addition to those for single rod cylinders shown on preceding pages and provide the information needed to completely dimension a double rod cylinder. On a double rod cylinder where the two rod ends are different, be sure to clearly state which rod end is to be assembled at which end.

Port position 1 is standard. If other than standard, specify pos. 2, 3 or 4 when viewed from one end only.

7"- 14" Bore

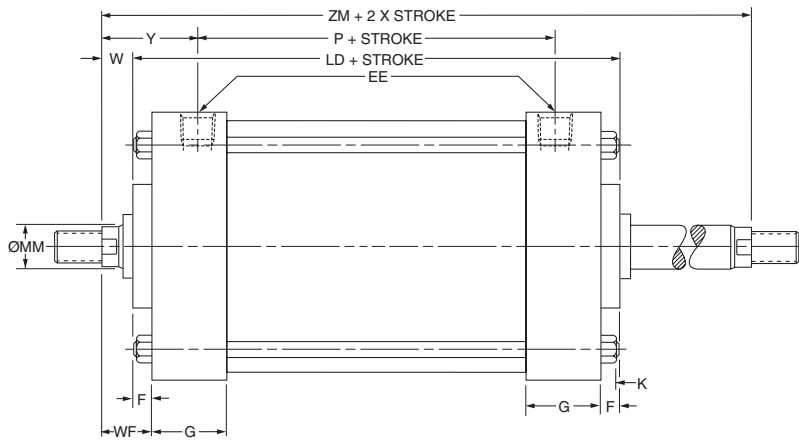

Rod End Dimensions — see table 2

Thread Style 2
Small Male

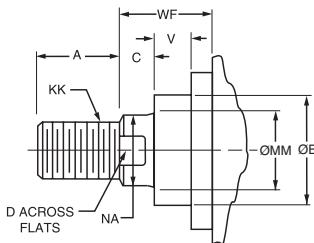

Thread Style 4
Short Female

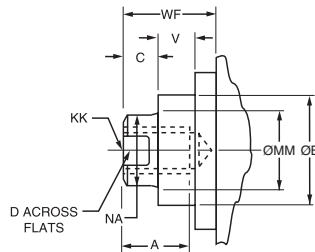

Thread Style 5
Intermediate Male

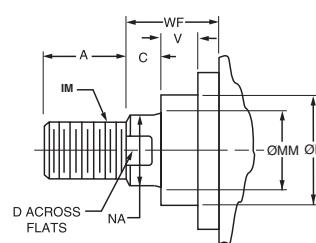

“Special” Thread Style X

Special thread, extension, rod eye, blank, etc., are also available.

To order, specify “Style X” and give desired dimensions for KK, A and WF. If otherwise special, furnish dimensioned sketch.

A high strength rod end stud is supplied on thread style 2 through 2" diameter rods and on thread style 5 through 1 3/8" diameter rods. Larger sizes or special rod ends are cut threads. Style 2 rod ends are recommended where the workpiece is secured against the rod shoulder. When the workpiece is not shouldered, style 2 rod ends

are recommended through 2" piston rod diameters and style 5 rod ends are recommended on larger diameters. Use style 4 for applications where female rod end threads are required. If rod end is not specified, style 2 will be supplied.

Miller AV Series Heavy-Duty Air Cylinders

Double Rod End Cylinders
7" to 14" Bore Sizes

Table 1—Envelope and Mounting Dimensions

Bore	E	EE NPTF	F	G	K	Add Stroke		
						LD	P	SS
7	7 ¹ / ₂	³ / ₄	³ / ₄	2	⁹ / ₁₆	7 ¹ / ₈	3 ¹ / ₄	4 ¹ / ₄
8	8 ¹ / ₂	³ / ₄	³ / ₄	2	⁹ / ₁₆	7 ¹ / ₈	3 ¹ / ₄	4 ¹ / ₄
10	10 ⁵ / ₈	1	³ / ₄	2 ¹ / ₄	¹¹ / ₁₆	8 ¹ / ₈	4 ¹ / ₈	4 ⁷ / ₈
12	12 ³ / ₄	1	³ / ₄	2 ¹ / ₄	¹¹ / ₁₆	8 ⁵ / ₈	4 ⁵ / ₈	5 ³ / ₈
14	14 ³ / ₄	1 ¹ / ₄	³ / ₄	2 ³ / ₄	³ / ₄	10 ¹ / ₈	5 ¹ / ₂	6 ³ / ₈

Table 2—Rod End Dimensions and Envelope Dimensions Affected By Rod Size

Bore	MM Rod Ø	Thread		Rod End Dimensions and Envelope Dimensions Affected By Rod Size										Add Stroke ZM
		Style 5 IM	Style 2 & 4 KK	A	B Ø +.000 -.002	C	D	NA	V	W	WF	Y		
7	1 ³ / ₈	1 ¹ / ₄ -12	1-14	1 ⁵ / ₈	1.999	⁵ / ₈	1 ¹ / ₈	1 ⁵ / ₁₆	¹ / ₄	⁷ / ₈	1 ⁵ / ₈	2 ¹³ / ₁₆	8 ⁷ / ₈	
	1 ³ / ₄	1 ¹ / ₂ -12	1 ¹ / ₄ -12	2	2.374	³ / ₄	1 ¹ / ₂	1 ¹¹ / ₁₆	³ / ₈	1 ¹ / ₈	1 ⁷ / ₈	3 ¹ / ₁₆	9 ³ / ₈	
	2	1 ³ / ₄ -12	1 ¹ / ₂ -12	2 ¹ / ₄	2.624	⁷ / ₈	1 ¹¹ / ₁₆	1 ¹⁵ / ₁₆	³ / ₈	1 ¹ / ₄	2	3 ³ / ₁₆	9 ⁵ / ₈	
8	1 ³ / ₈	1 ¹ / ₄ -12	1-14	1 ⁵ / ₈	1.999	⁵ / ₈	1 ¹ / ₈	1 ⁵ / ₁₆	¹ / ₄	⁷ / ₈	1 ⁵ / ₈	2 ¹³ / ₁₆	8 ⁷ / ₈	
	5 ¹ / ₂	5 ¹ / ₄ -12	4-12	5 ¹ / ₂	6.249	1	4 ⁵ / ₈	5 ³ / ₈	¹ / ₂	1 ¹ / ₂	2 ¹ / ₄	3 ⁷ / ₁₆	10 ¹ / ₈	
	1 ³ / ₄	1 ¹ / ₂ -12	1 ¹ / ₄ -12	2	2.374	³ / ₄	1 ¹ / ₂	1 ¹¹ / ₁₆	³ / ₈	1 ¹ / ₈	1 ⁷ / ₈	3 ¹ / ₁₆	9 ³ / ₈	
	2	1 ³ / ₄ -12	1 ¹ / ₂ -12	2 ¹ / ₄	2.624	⁷ / ₈	1 ¹¹ / ₁₆	1 ¹⁵ / ₁₆	³ / ₈	1 ¹ / ₄	2	3 ³ / ₁₆	9 ⁵ / ₈	
	2 ¹ / ₂	2 ¹ / ₄ -12	1 ⁷ / ₈ -12	3	3.124	1	2 ¹ / ₁₆	2 ³ / ₈	¹ / ₂	1 ¹ / ₂	2 ¹ / ₄	3 ⁷ / ₁₆	10 ¹ / ₈	
	3	2 ³ / ₄ -12	2 ¹ / ₄ -12	3 ¹ / ₂	3.749	1	2 ⁵ / ₈	2 ⁷ / ₈	¹ / ₂	1 ¹ / ₂	2 ¹ / ₄	3 ⁷ / ₁₆	10 ¹ / ₈	
	3 ¹ / ₂	3 ¹ / ₄ -12	2 ¹ / ₂ -12	3 ¹ / ₂	4.249	1	3	3 ³ / ₈	¹ / ₂	1 ¹ / ₂	2 ¹ / ₄	3 ⁷ / ₁₆	10 ¹ / ₈	
	4	3 ³ / ₄ -12	3-12	4	4.749	1	3 ³ / ₈	3 ⁷ / ₈	¹ / ₂	1 ¹ / ₂	2 ¹ / ₄	3 ⁷ / ₁₆	10 ¹ / ₈	
10	4 ¹ / ₂	4 ¹ / ₄ -12	3 ¹ / ₄ -12	4 ¹ / ₂	5.249	1	3 ⁷ / ₈	4 ³ / ₈	¹ / ₂	1 ¹ / ₂	2 ¹ / ₄	3 ⁷ / ₁₆	10 ¹ / ₈	
	5	4 ³ / ₄ -12	3 ¹ / ₂ -12	5	5.749	1	4 ¹ / ₄	4 ⁷ / ₈	¹ / ₂	1 ¹ / ₂	2 ¹ / ₄	3 ⁷ / ₁₆	10 ¹ / ₈	
	1 ³ / ₄	1 ¹ / ₂ -12	1 ¹ / ₄ -12	2	2.374	³ / ₄	1 ¹ / ₂	1 ¹¹ / ₁₆	³ / ₈	1 ¹ / ₈	1 ⁷ / ₈	3 ¹ / ₈	10 ³ / ₈	
	2	1 ³ / ₄ -12	1 ¹ / ₂ -12	2 ¹ / ₄	2.624	⁷ / ₈	1 ¹¹ / ₁₆	1 ¹⁵ / ₁₆	³ / ₈	1 ¹ / ₄	2	3 ¹ / ₄	10 ⁵ / ₈	
	2 ¹ / ₂	2 ¹ / ₄ -12	1 ⁷ / ₈ -12	3	3.124	1	2 ¹ / ₁₆	2 ³ / ₈	¹ / ₂	1 ¹ / ₂	2 ¹ / ₄	3 ¹ / ₂	11 ¹ / ₈	
	3	2 ³ / ₄ -12	2 ¹ / ₄ -12	3 ¹ / ₂	3.749	1	2 ⁵ / ₈	2 ⁷ / ₈	¹ / ₂	1 ¹ / ₂	2 ¹ / ₄	3 ¹ / ₂	11 ¹ / ₈	
	3 ¹ / ₂	3 ¹ / ₄ -12	2 ¹ / ₂ -12	3 ¹ / ₂	4.249	1	3	3 ³ / ₈	¹ / ₂	1 ¹ / ₂	2 ¹ / ₄	3 ¹ / ₂	11 ¹ / ₈	
	4	3 ³ / ₄ -12	3-12	4	4.749	1	3 ³ / ₈	3 ⁷ / ₈	¹ / ₂	1 ¹ / ₂	2 ¹ / ₄	3 ¹ / ₂	11 ¹ / ₈	
12	4 ¹ / ₂	4 ¹ / ₄ -12	3 ¹ / ₄ -12	4 ¹ / ₂	5.249	1	3 ⁷ / ₈	4 ³ / ₈	¹ / ₂	1 ¹ / ₂	2 ¹ / ₄	3 ¹ / ₂	11 ¹ / ₈	
	5	4 ³ / ₄ -12	3 ¹ / ₂ -12	5	5.749	1	4 ¹ / ₄	4 ⁷ / ₈	¹ / ₂	1 ¹ / ₂	2 ¹ / ₄	3 ¹ / ₂	11 ¹ / ₈	
	5 ¹ / ₂	5 ¹ / ₄ -12	4-12	5 ¹ / ₂	6.249	1	4 ⁵ / ₈	5 ³ / ₈	¹ / ₂	1 ¹ / ₂	2 ¹ / ₄	3 ¹ / ₂	11 ¹ / ₈	
	2	1 ³ / ₄ -12	1 ¹ / ₂ -12	2 ¹ / ₄	2.624	⁷ / ₈	1 ¹¹ / ₁₆	1 ¹⁵ / ₁₆	³ / ₈	1 ¹ / ₄	2	3 ¹ / ₄	11 ¹ / ₈	
	2 ¹ / ₂	2 ¹ / ₄ -12	1 ⁷ / ₈ -12	3	3.124	1	2 ¹ / ₁₆	2 ³ / ₈	¹ / ₂	1 ¹ / ₂	2 ¹ / ₄	3 ¹ / ₂	11 ¹ / ₈	
	3	2 ³ / ₄ -12	2 ¹ / ₄ -12	3 ¹ / ₂	3.749	1	2 ⁵ / ₈	2 ⁷ / ₈	¹ / ₂	1 ¹ / ₂	2 ¹ / ₄	3 ¹ / ₂	11 ¹ / ₈	
	3 ¹ / ₂	3 ¹ / ₄ -12	2 ¹ / ₂ -12	3 ¹ / ₂	4.249	1	3	3 ³ / ₈	¹ / ₂	1 ¹ / ₂	2 ¹ / ₄	3 ¹ / ₂	11 ¹ / ₈	
	4	3 ³ / ₄ -12	3-12	4	4.749	1	3 ³ / ₈	3 ⁷ / ₈	¹ / ₂	1 ¹ / ₂	2 ¹ / ₄	3 ¹ / ₂	11 ¹ / ₈	
14	4 ¹ / ₂	4 ¹ / ₄ -12	3 ¹ / ₄ -12	4 ¹ / ₂	5.249	1	3 ⁷ / ₈	4 ³ / ₈	¹ / ₂	1 ¹ / ₂	2 ¹ / ₄	3 ¹ / ₂	11 ¹ / ₈	
	5	4 ³ / ₄ -12	3 ¹ / ₂ -12	5	5.749	1	4 ¹ / ₄	4 ⁷ / ₈	¹ / ₂	1 ¹ / ₂	2 ¹ / ₄	3 ¹ / ₂	11 ¹ / ₈	
	5 ¹ / ₂	5 ¹ / ₄ -12	4-12	5 ¹ / ₂	6.249	1	4 ⁵ / ₈	5 ³ / ₈	¹ / ₂	1 ¹ / ₂	2 ¹ / ₄	3 ¹ / ₂	11 ¹ / ₈	
	2 ¹ / ₂	2 ¹ / ₄ -12	1 ⁷ / ₈ -12	3	3.124	1	2 ¹ / ₁₆	2 ³ / ₈	¹ / ₂	1 ¹ / ₂	2 ¹ / ₄	3 ¹³ / ₁₆	13 ¹ / ₈	
	3	2 ³ / ₄ -12	2 ¹ / ₄ -12	3 ¹ / ₂	3.749	1	2 ⁵ / ₈	2 ⁷ / ₈	¹ / ₂	1 ¹ / ₂	2 ¹ / ₄	3 ¹³ / ₁₆	13 ¹ / ₈	
	3 ¹ / ₂	3 ¹ / ₄ -12	2 ¹ / ₂ -12	3 ¹ / ₂	4.249	1	3	3 ³ / ₈	¹ / ₂	1 ¹ / ₂	2 ¹ / ₄	3 ¹³ / ₁₆	13 ¹ / ₈	

Miller AV Series Heavy-Duty Air Cylinders

Spherical Bearing Mount
1 1/2" to 14" Bore Sizes

Spherical Bearings for AV Cylinders Spherical Bearing Mount That Maintains Alignment Through Push and Pull Strokes.

Benefits Are...

- Simplify installation of cylinder
- Reduce cylinder friction
- Eliminate side loading in hard to align applications
- Increase cylinder life by reducing wear on piston and rod bearings
- Save assembly time
- Maintain alignment through push and pull strokes
- Increase rod bearing and rod seal life
- Simplify machine design problems



AV Series pneumatic cylinders are available with spherical bearing mounts at both ends or head and cap end only. The bearing at the cap end is housed in a single stud ear welded to the cap to form an integral structure. At the head end the bearing is mounted in a steel rod eye threaded to the piston rod. Grease fittings are provided for lubrication.

The spherical bearing mount provides swivel connections at both ends of the cylinder to reduce

misalignment problems and to maintain alignment through push and pull strokes.

The bearing races are designed primarily for radial loads and moderate misalignment not to exceed angle "a" as shown in Table 1 on the next page.

The accessories, rod eye, pivot pin and clevis brackets are all designed to take maximum loading of the cylinder.

Miller AV Series Heavy-Duty Air Cylinders

Spherical Bearing Mount
Application and Design Data and
Mounting Information

Application and Design Data

The spherical bearing life is influenced by many factors, i.e., bearing pressure, load direction, oscillating angle and lubrication. The 250 PSI operating pressure rating of the spherical bearing mountings is based on standard commercial bearing ratings.

The spherical bearings are dimensioned to ensure a satisfactory bearing life under normal operating conditions. The bearing races are made of through-hardened steel and are precision ground. They are phosphate treated and coated with dry film lubricant to minimize friction of contacting surfaces. In the case of a permanent unidirectional load to the bearing, or other unusual operating conditions, the use of a larger bearing may be required.

For longer bearing life, regular lubrication will protect the spherical plain bearing from premature wear and corrosion. Rust-inhibiting EP greases of lithium/lead base, preferably with molybdenum disulphide additives are particularly suited. The radial bearings have lubricating holes and grooves in the races permitting lubrication. The bearing housings at the cap and rod end are provided with grease fittings for lubrication.

Maximum angle of swivel in relation to the center line of the pivot pin is shown as angle *a* in the table below. It is recommended that this angle is not exceeded when mounting the cylinder.

Mounting Information

Head End Mounting

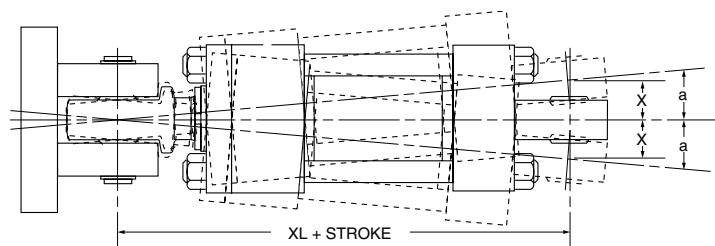

Recommended maximum swivel angle on each side of the cylinder centerline.

Table 1

Bore	Head End Mounted		Cap End Mounted	
	Angle a	Tan. of a	Angle a	Tan. of a
1½	2°	.035	2°	.035
2	2½°	.044	4½°	.079
2½	2½°	.044	4½°	.079
3¼	3°	.052	3°	.052
4	2½°	.044	3°	.052
5 - 14	3°	.052	3°	.052

Note: Dimension X is the maximum off center mounting of the cylinder. To determine dimension X for various stroke lengths multiply distance between pivot pin holes by tangent of angle *a*. For extended position use $X = XL + 2X$ stroke.

Cap End Mounting

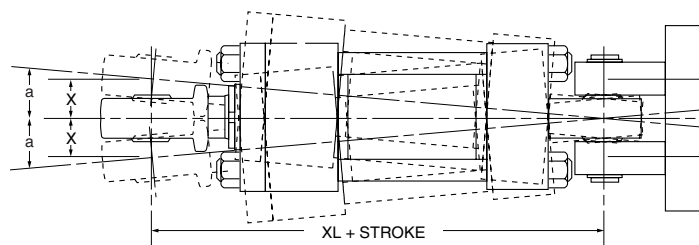

Miller AV Series Heavy-Duty Air Cylinders

Spherical Bearing Mount
1 1/2" to 14" Bore Sizes

Cap Fixed Eye Mount with Spherical Bearing Model 94

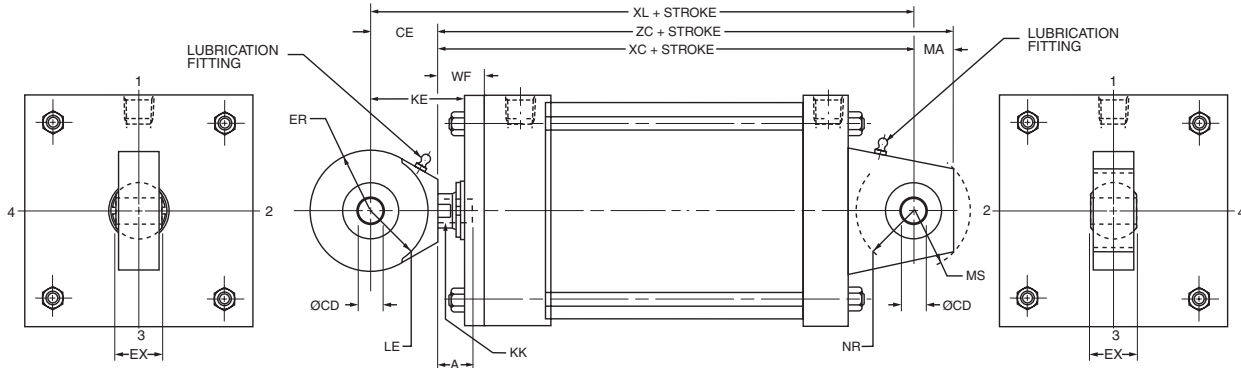

Bore	MM Rod Ø	Thread** Style 4 KK	A	WF	Add Stroke			KE	CDØ*	CE	ER	EX	LE	MA	MS	NR	Max. Oper. PSI AV
					XC	XL	ZC										
1 1/2	5/8	7/16-20	3/4	1	5 3/8	6 1/4	6 1/8	1 1/2	-.0005 .5000	7/8	13/16	7/16	3/4	3/4	15/16	5/8	250
	1	3/4-16	1 1/8	1 3/8	5 3/4	6 5/8	6 1/2	1 7/8									
2	5/8	7/16-20	3/4	1	5 3/8	6 1/4	6 1/8	1 1/2	-.0005 .5000	7/8	13/16	7/16	3/4	3/4	15/16	5/8	250
	1 3/8	1-14	1 5/8	1 5/8	6	6 7/8	6 3/4	2 1/8									
2 1/2	5/8	7/16-20	3/4	1	5 3/8	6 1/4	6 1/8	1 1/2	-.0005 .5000	7/8	13/16	7/16	3/4	3/4	15/16	5/8	250
	1 3/4	1-14	1 5/8	1 5/8	6 1/8	7	6 7/8	2 1/8									
3 1/4	1	3/4-16	1 1/8	1 3/8	6 7/8	8 1/8	7 7/8	2	-.0005 .7500	1 1/4	1 1/8	2 1/32	1 1/16	1	1 3/8	1	250
	1 3/8	1-14	1 5/8	1 5/8	7 1/8	8 3/8	8 1/8	2 1/4									
4	1 3/4	1 1/4-12	2	1 7/8	7 3/8	8 5/8	8 3/8	2 1/2	-.0005 .7500	1 1/4	1 1/8	2 1/32	1 1/16	1	1 3/8	1	250
	2 1/2	1 1/8-12	3	2 1/4	7 3/4	9	8 3/4	2 7/8									
5	1	3/4-16	1 1/8	1 3/8	7 1/8	8 3/8	8 1/8	2	-.0005 .7500	1 1/4	1 1/8	2 1/32	1 1/16	1	1 3/8	1	250
	3 1/2	2 1/2-12	3 1/2	2 1/4	8	9 1/4	9	2 7/8									
6	1 3/8	1-14	1 5/8	1 5/8	7 3/8	8 5/8	8 3/8	2 1/4	-.0005 1.0000	1 7/8	1 1/4	7/8	1 7/16	1 1/4	1 11/16	1 1/4	250
	2 1/2	1 1/8-12	3	2 1/4	8	9 1/4	9	2 7/8									

Maximum operating pressure is based on tensile strength of material. Pressure ratings are based on standard commercial bearing ratings.

*Dimension CD is hole diameter.

**To match pin diameter in rod eye and cap, when an oversize rod is required, specify rod end style 'X', 'KK' thread and 'A' thread length for the standard rod diameter (first rod listed for the bore), and 'W' for the oversize rod. Order the rod eye and clevis bracket for the required bore size from the tables on the Spherical Bearing Accessories page.

Miller AV Series Heavy-Duty Air Cylinders

Spherical Bearing Mount
1 1/2" to 14" Bore Sizes

Cap Fixed Eye Mount
with Spherical Bearing
Model 94

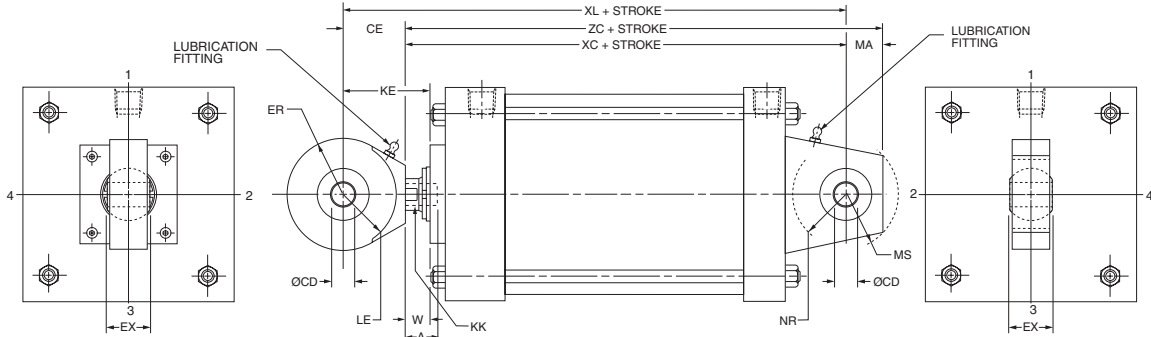

Bore	MM Rod Ø	Thread** Style 4 KK	A	W	Add Stroke			KE	CDØ*	CE	ER	EX	LE	MA	MS	NR	Max. Oper. PSI AV
					XC	XL	ZC										
8	1 3/8	1-14	1 5/8	7/8	8 1/4	10 1/8	9 1/2	2 3/4	-0.0005 1.0000	1 7/8	1 1/4	7/8	1 7/16	1 1/4	1 11/16	1 1/4	250
	5 1/2	4-12	5 1/2	1 1/2	8 7/8	10 3/4	10 1/8	3 3/8									
	1 3/4	1 1/4-12	2	1 1/8	8 1/2	10 3/8	9 3/4	3									
	2	1 1/2-12	2 1/4	1 1/4	8 5/8	10 1/2	9 7/8	3 1/8									
	2 1/2	1 7/8-12	3	1 1/2	8 7/8	10 3/4	10 1/8	3 3/8									
	3	2 1/4-12	3 1/2	1 1/2	8 7/8	10 3/4	10 1/8	3 3/8									
	3 1/2	2 1/2-12	3 1/2	1 1/2	8 7/8	10 3/4	10 1/8	3 3/8									
	4	3-12	4	1 1/2	8 7/8	10 3/4	10 1/8	3 3/8									
10	4 1/2	3 1/4-12	4 1/2	1 1/2	8 7/8	10 3/4	10 1/8	3 3/8	-0.0005 1.3750	2 1/8	1 11/16	1 3/16	1 7/8	2 7/16	1 5/8	250	
	5	3 1/2-12	5	1 1/2	8 7/8	10 3/4	10 1/8	3 3/8									
	1 3/4	1 1/4-12	2	1 1/8	10 3/8	12 1/2	12 1/4	3 1/4									
	2	1 1/2-12	2 1/4	1 1/4	10 1/2	12 5/8	12 3/8	3 3/8									
	2 1/2	1 7/8-12	3	1 1/2	10 3/4	12 7/8	12 5/8	3 5/8									
	3	2 1/4-12	3 1/2	1 1/2	10 3/4	12 7/8	12 5/8	3 5/8									
	3 1/2	2 1/2-12	3 1/2	1 1/2	10 3/4	12 7/8	12 5/8	3 5/8									
12	4 1/2	3 1/4-12	4 1/2	1 1/2	10 3/4	12 7/8	12 5/8	3 5/8	-0.0005 1.7500	2 1/2	2 1/16	1 17/32	2 1/8	2 1/2	2 7/8	2 1/16	250
	5 1/2	4-12	5 1/2	1 1/2	10 3/4	12 7/8	12 5/8	3 5/8									
	2	1 1/2-12	2 1/4	1 1/4	11 3/8	13 5/8	13 3/8	3 3/4									
	2 1/2	1 7/8-12	3	1 1/2	11 3/8	13 7/8	13 7/8	4									
	3	2 1/4-12	3 1/2	1 1/2	11 3/8	13 7/8	13 7/8	4									
	3 1/2	2 1/2-12	3 1/2	1 1/2	11 3/8	13 7/8	13 7/8	4									
	4	3-12	4	1 1/2	11 3/8	13 7/8	13 7/8	4									
14	4 1/2	3 1/4-12	4 1/2	1 1/2	11 3/8	13 7/8	13 7/8	4	-0.0005 2.0000	2 3/4	2 1/2	1 3/4	2 1/2	2 1/2	3 5/16	2 3/8	250
	5	3 1/2-12	5	1 1/2	11 3/8	13 7/8	13 7/8	4									
	2 1/2	1 7/8-12	3	1 1/2	12 7/8	15 5/8	15 3/8	4 1/4									
	3	2 1/4-12	3 1/2	1 1/2	12 7/8	15 5/8	15 3/8	4 1/4									
	3 1/2	2 1/2-12	3 1/2	1 1/2	12 7/8	15 5/8	15 3/8	4 1/4									
	4	3-12	4	1 1/2	12 7/8	15 5/8	15 3/8	4 1/4									

Maximum operating pressure is based on tensile strength of material. Pressure ratings are based on standard commercial bearing ratings.

*Dimension CD is hole diameter.

**To match pin diameter in rod eye and cap, when an oversize rod is required, specify rod end style 'X', 'KK' thread and 'A' thread length for the standard rod diameter (first rod listed for the bore), and 'W' for the oversize rod. Order the rod eye and clevis bracket for the required bore size from the tables on the Spherical Bearing Accessories page.

Miller AV Series Heavy-Duty Air Cylinders

Spherical Bearing Mount
Cylinder Accessories

Cylinder Accessories

Spherical Bearing Mount – Model 92

Schrader Bellows offers a complete range of Cylinder Accessories to assure you of the greatest versatility in present or future cylinder applications. Accessories offered for the respective cylinder include the Rod Eye,

Pivot Pin and Clevis Bracket. To select the proper part number for any desired accessory refer to the charts below.

Spherical Rod Eye Dimensions

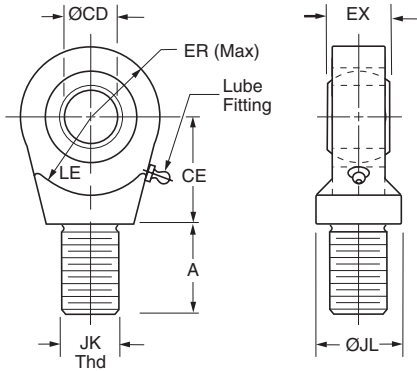

PA-2 Series Bore Ø	Part Number	CD Ø	A	CE	EX	ER	LE	JK Thread	JL Ø	Load Capacity (lb)
1.50, 2.00, 2.50	0961000050	.5000 ⁻⁰⁰⁰⁵	0.72	0.86	0.44	0.80	0.78	7/16-20	0.88	2644
3.25, 4.00, 5.00	0961000075	.7500 ⁻⁰⁰⁰⁵	1.02	1.25	0.66	1.14	1.06	3/4-16	1.31	9441
6.00, 8.00	0961000100	1.0000 ⁻⁰⁰⁰⁵	1.52	1.88	0.88	1.34	1.45	1-14	1.50	16860
10.00	0961000138	1.3750 ⁻⁰⁰⁰⁵	2.02	2.13	1.19	1.67	1.91	1 1/4-12	2.00	28562
12.00	0961000175	1.7500 ⁻⁰⁰⁰⁵	2.14	2.50	1.53	2.05	2.16	1 1/2-12	2.00	43005
14.00	0961000200	2.0000 ⁻⁰⁰⁰⁵	2.89	2.75	1.75	2.60	2.50	1 7/8-12	2.75	70193

Order to fit Piston Rod Thread Size.

Pivot Pin Dimensions

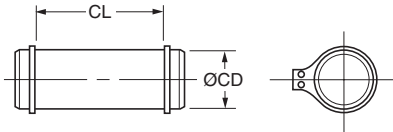

Pivot Pins are furnished with (2) Retainer Rings.

PA-2 Series Bore Ø	Part Number	CD Ø	CL	Shear Capacity (lb)
1.50, 2.00, 2.50	0839620000	.4997 ⁻⁰⁰⁰⁴	1.56	8600
3.25, 4.00, 5.00	0839630000	.7497 ⁻⁰⁰⁰⁵	2.03	19300
6.00, 8.00	0839640000	.9997 ⁻⁰⁰⁰⁵	2.50	34300
10.00	0839650000	1.3746 ⁻⁰⁰⁰⁶	3.31	65000
12.00	0839660000	1.7496 ⁻⁰⁰⁰⁶	4.22	105200
14.00	0839670000	1.9996 ⁻⁰⁰⁰⁷	4.94	137400

Clevis Bracket Dimensions

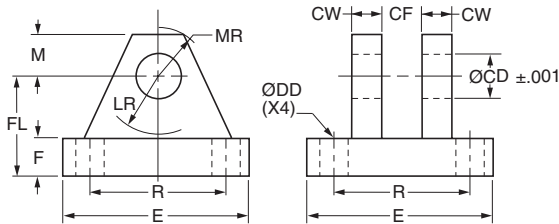

Fabricated Steel

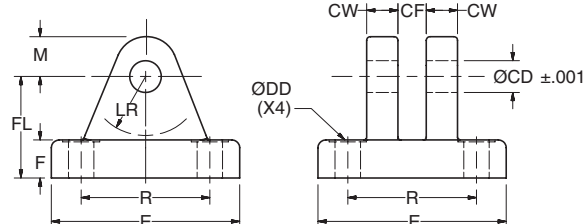

Cast Ductile Iron

Order to fit Cylinder Cap or Rod Eye.

PA-2 Series Bore Ø	Pin Ø	Cast Ductile Iron Part Number	Fabricated Steel Part Number	CD Ø	CF	CW	DD Ø	E	F	FL	LR	M	MR	R	Load Capacity (lb)
1.50, 2.00, 2.50	0.500	0959450000	0839470000	0.503	0.45	0.50	0.41	3.00	0.50	1.50	0.94	0.50	0.63	2.05	5770
3.25, 4.00, 5.00	0.750	0959300000	0839480000	0.753	0.67	0.63	0.53	3.75	0.63	2.00	1.38	0.88	1.00	2.76	9450
6.00, 8.00	1.000	0959310000	0839490000	1.003	0.89	0.75	0.53	5.50	0.75	2.50	1.69	1.00	1.19	4.10	14300
10.00	1.375	0959320000	0839500000	1.378	1.20	1.00	0.66	6.50	0.88	3.50	2.44	1.38	1.63	4.95	20322
12.00	1.750	0959330000	0839510000	1.753	1.55	1.25	0.91	8.50	1.25	4.50	2.88	1.75	2.06	6.58	37800
14.00	2.000	0959340000	0839520000	2.003	1.77	1.50	0.91	10.63	1.50	5.00	3.00	2.00	2.38	7.92	50375

Miller AVN Series Heavy-Duty Air Cylinders

AVN Series
Non-Lube

Miller Fluid Power Non-Lube Heavy-Duty Air Cylinders

AVN Series



For millions of trouble free cycles

- Nominal pressure — 250 PSI — Air Service
- Standard Bore Sizes — 1½" through 14"
- Piston Rod Diameters — 5⁄8" through 5½"
- 17 Standard Mounting Styles
- NFPA Interchangeable

Miller AVN Series Heavy-Duty Air Cylinders

AVN Series
Non-Lube

The AVN Series Non-Lube Air Cylinder with Proven Performance Millions of trouble free cycles with... **ZERO LEAKAGE.**

Piston Lipseals

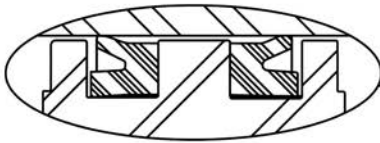

Rod Seal & Rod Wiper

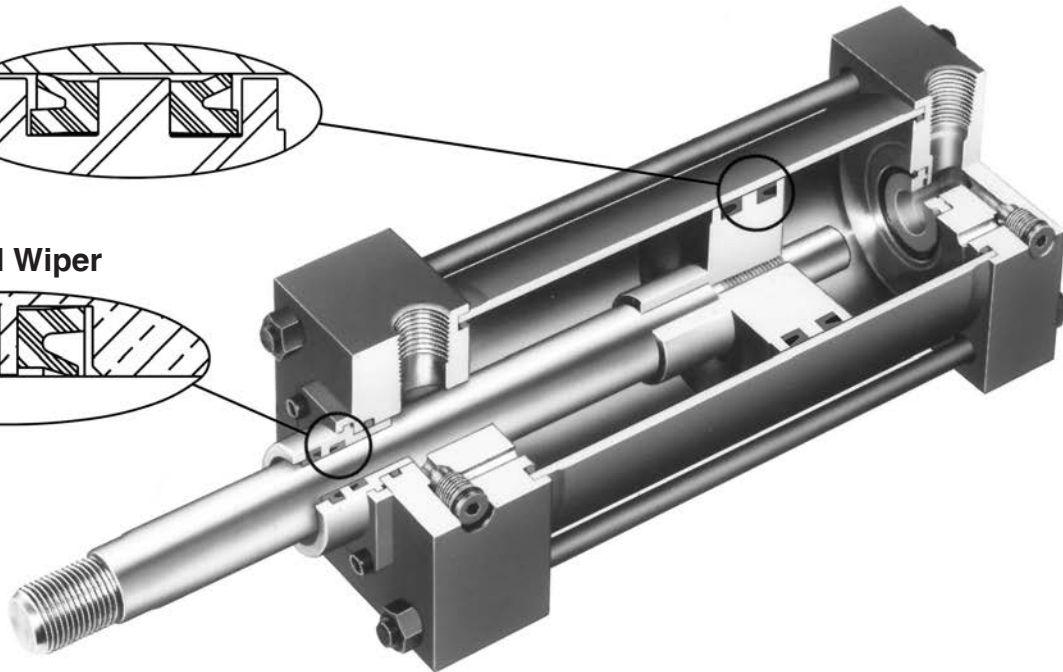

Increased Market Demand, continuous research, and testing efforts inspired the development of the AVN Series Non-Lubricated Air Cylinder. The AVN Series piston rod and cylinder tube surfaces act as highly efficient lubricant reservoirs, maintaining their own lubricant film. Other manufacturers pack grease into grooves and pockets and call them reservoirs. The fact of the matter is that as those grooves empty out over time; grease is being transported out of the cylinder and into the control system components and the atmosphere. The AVN Series concept eliminates that problem by maintaining the lubricant film where it belongs: on the seals, bearing surfaces, piston rod and cylinder bore.

Benefits include...long seal and bearing life and since no oil is added through the use of lubricators – no oil is expelled into the atmosphere with the exhaust air as the cylinder strokes.

Anatomy of AVN Series Sealing and Lubricant Retention Systems

Rounded sealing lip glides over lubricant film instead of scraping it off. Reduces friction, increases life and eliminates the need for added lubrication.

Increased heel thickness and outer lip extension improve stability, resist rolling.

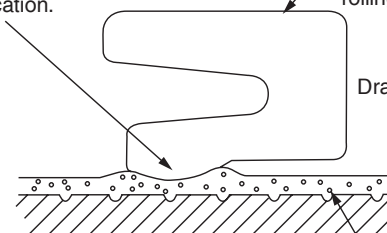

Drawing not to scale

High integrity lubricant film with suspended PTFE particles

Miller AVN Series Heavy-Duty Air Cylinders

AVN Series
Specifications
How to Order

In the AVN Series you get all the cost saving benefits and features of the heavy-duty AV Series air cylinder including...

- Bolted Bushing Assembly for positive no leak sealing
 - Piston rod, hard chrome-plated and case-hardened steel
 - High strength rolled thread Piston Rod Stud
 - Steel tube with chrome-plated micro finish bore...
- Plus** the innovative “Non-Lube” feature which further increases your benefits of lower operating and maintenance costs.

Standard Specifications

- Heavy-Duty Service — ANSI/(NFPA) T3.6.7 R3-2009 Mounting Dimension Standards
- Standard Construction — Square Head — Tie Rod Design
- Standard Temperature — 10°F to +165°F
- Standard Fluid — Filtered Air
- Strokes — Available in any practical stroke length
- Cushions — Optional at either end or both ends of stroke. “Float Check” at cap end.

In line with our policy of continuing product improvement, specifications in this bulletin are subject to change.

Available Bore and Rod Sizes

Bore Sizes Available	1½"	2"	2½"	3¼"	4"	5"	6"	8"	10"	12"	14"
-----------------------------	-----	----	-----	-----	----	----	----	----	-----	-----	-----

Rod Sizes Available	5/8"	1"	1¾"	1¾"	2"	2½"	3"	3½"	4"	4½"	5"	5½"
----------------------------	------	----	-----	-----	----	-----	----	-----	----	-----	----	-----

How to Order AVN Series Non-Lube Air Cylinders

Data Required on all AVN Cylinder Orders

When ordering AVN Series cylinders, be sure to specify each of the following requirements:

(Note: Duplicate cylinders can be ordered by giving the SERIAL NUMBER from the original cylinder. Factory records supply a quick, positive identification.)

a) Bore Size

b) Mounting Style

Specify your choice of mounting style — as shown in this catalog.

c) Series Designation (AVN)

d) Length of Stroke

e) Piston Rod Diameter

Specify rod diameter, standard rod diameters will be furnished if not otherwise specified, unless length of stroke makes the application questionable.

f) Piston Rod End Thread Style

Give thread style number or specify dimensions. Thread style number 2 will be supplied if not otherwise specified.

g) Cushions (if required)

Specify “Cushion-rod end,” “Cushion-cap end” or “Cushion-both ends” as required. If cylinder is to have a double rod and only one cushion is required, be sure to specify clearly which end of the cylinder is to be cushioned.

Miller AV Series Heavy-Duty Air Cylinders

Cylinder
Accessories

Cylinder Accessories

Miller offers a complete range of cylinder accessories to assure you of the greatest versatility in present and future cylinder applications.

Rod End Accessories

Accessories offered for the rod end of the cylinder include Rod Clevis, Eye Bracket, Rod Eye, Clevis Bracket, and Pivot Pin. To select the proper part number for any desired accessory, refer to the table below or on the opposite page and look in the row to the right of the rod thread in the first column. For economical accessory selection, it is recommended that rod end style 2 be specified on your cylinder order.

Accessory Load Capacity

The various accessories have been load rated for your convenience. The load Capacity in lbs. Is the recommended maximum load for that accessory based on a 4:1 design factor in tension. (Pivot Pin is rated in shear.) Before specifying, compare the actual load or the tension (pull) force at maximum operating pressure of the cylinder with the load capacity of the accessory you plan to use. If load or pull force of cylinder exceeds load capacity of accessory, consult factory.

Chart A

Thread Size	Pin Ø	Rod Clevis		Eye Bracket		Pivot Pin	
		Part Number	Load Capacity (lb)	Forged Steel or Cast Ductile Iron		Part Number	Shear Capacity (lb)
				Part Number	Load Capacity (lb)		
5/16-24	0.312	0512210000 ¹	2600	0959810031	1850	–	–
7/16-20	0.500	0509400000	4250	0959810050 ²	4620	0683680000	8600
1/2-20	0.500	0509410000	4900	0959810050 ²	4620	0683680000	8600
3/4-16	0.750	0509420000	11200	0959810075 ²	12370	0683690000	19300
3/4-16	0.750	1332840000	11200	0959810075 ²	12370	0683690000	19300
7/8-14	1.000	0509430000	18800	0959810100 ²	20450	0683700000	34300
1-14	1.000	0509440000	19500	0959810100 ²	20450	0683700000	34300
1-14	1.000	1332850000	19500	0959810100 ²	20450	0683700000	34300
1 1/4-12	1.375	0509450000	33500	0959810138	33500	0683710000	65000
1 1/4-12	1.375	1332860000	33500	0959810138	33500	0683710000	65000
1 1/2-12	1.750	0509460000	45600	0959810175	49480	0683720000	105200
1 3/4-12	2.000	0509470000	65600	0959810200 ²	70100	0683730000	137400
1 7/8-12	2.000	0509480000	65600	0959810200 ²	70100	0683730000	137400
2 1/4-12	2.500	0509490000	98200	0959810250 ²	98200	0683740000	214700
2 1/2-12	3.000	0509500000	98200	0959810300 ²	121940	0683750000	309200
2 3/4-12	3.000	0509510000	98200	0959810300 ²	121940	0683750000	309200
3 1/4-12	3.500	0509520000	156700	0959810350	187910	0735450000	420900
3 1/2-12	4.000	0509530000	193200	0959810400	268000	0735470000	565800
4-12	4.000	0509540000	221200	0959810400	268000	0735470000	565800

¹ Includes pivot pin.

² Cylinder accessory dimensions conform to ANSI/NFPA/T3.6.8 R3-2010.

Mounting Plates

Mounting Plates for Model 84 (clevis mounted) cylinders are offered. To select proper part number for your application, refer to Chart B at right.

Chart B

AV Series	
Eye Bracket Part Number	Bore Ø
0960160044	1.00
0959810050	1.50 , 2.00, 2.50
0959810075	3.25, 4.00, 5.00
0959810100	6.00, 8.00
0959810138	10.00
0959810175	12.00
0959810200	14.00

Miller AV Series Heavy-Duty Air Cylinders

Cylinder
Accessories

Rod Clevis Dimensions

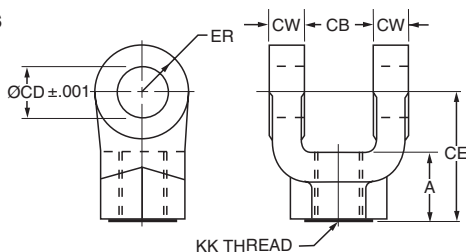

Part Number ¹	Pin Ø	A	CB	CD Ø	CE	CW	ER	KK Thread
0512210000 ²	0.310	0.81	0.34	0.314	2.25	0.20	0.30	5/16-24
0509400000	0.500	0.75	0.77	0.503	1.50	0.49	0.50	7/16-20
0509410000	0.500	0.75	0.77	0.503	1.50	0.49	0.50	1/2-20
0509420000	0.750	1.13	1.27	0.753	2.13	0.62	0.75	3/4-16
1332840000	0.750	1.13	1.27	0.753	2.38	0.62	0.75	3/4-16
0509430000	1.000	1.63	1.52	1.003	2.94	0.74	1.00	7/8-14
0509440000	1.000	1.63	1.52	1.003	2.94	0.74	1.00	1-14
1332850000	1.000	1.63	1.52	1.003	3.13	0.74	1.00	1-14
0509450000	1.375	1.88	2.04	1.378	3.75	0.99	1.38	1 1/4-12
1332860000	1.375	2.00	2.04	1.378	4.13	0.99	1.38	1 1/4-12
0509460000	1.750	2.25	2.54	1.753	4.50	1.24	1.75	1 1/2-12
0509470000	2.000	3.00	2.54	2.003	5.50	1.24	2.00	1 3/4-12
0509480000	2.000	3.00	2.54	2.003	5.50	1.24	2.00	1 7/8-12
0509490000	2.500	3.50	3.04	2.503	6.50	1.49	2.50	2 1/4-12
0509500000	3.000	3.50	3.04	3.003	6.75	1.49	2.75	2 1/2-12
0509510000	3.000	3.50	3.04	3.003	6.75	1.49	2.75	2 3/4-12
0509520000	3.500	3.50 ³	4.04	3.503	7.75	1.98	3.50	3 1/4-12
0509530000	4.000	4.00 ³	4.54	4.003	8.81	2.23	4.00	3 1/2-12
0509540000	4.000	4.00 ³	4.54	4.003	8.81	2.23	4.00	4-12

Pivot Pin Dimensions

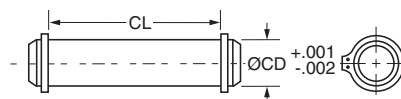

Part Number	CD Ø	CL
0683680000	0.500	1.88
0683690000	0.750	2.63
0683700000	1.000	3.13
0683710000	1.375	4.19
0683720000	1.750	5.19
0683730000	2.000	5.19
0683740000	2.500	6.19
0683750000	3.000	6.25
0735450000	3.500	8.25
0735470000 ⁴	4.000	9.00

⁴ This size supplied with cotter pins.

Notes:

- Pivot Pins are furnished with Clevis Mounted Cylinders as standard.
- Pivot Pins are furnished with (2) Retainer Rings.
- Pivot Pins must be ordered as a separate item if to be used with Rod Eyes, Rod Clevises, or Clevis Brackets.

¹ Rod Clevises with pin diameters 0.312 thru 1.375 are forged steel. Rod Clevises with 1.750 pin diameter and larger are cast ductile iron.

² Includes Pivot Pin

³ Consult appropriate cylinder rod end dimensions for compatibility.

Forged Steel or Cast Ductile Iron Mounting Plate or Eye Bracket Dimensions⁵

Note: Cast ductile iron eye brackets must not be welded in place.

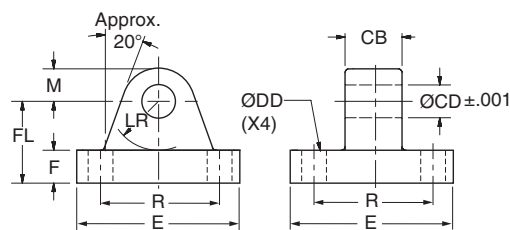

Cast or Forged ⁶ Part Number	Pin Ø	CB	CD Ø	DD Ø	E (As Cast)	F	FL	LR	M (As Cast)	R
0959810031	0.312	0.31	0.314	0.27	2.25	0.38	1.00	0.59	0.38	1.75
0959810050	0.500	0.75	0.503	0.41	2.50	0.38	1.13	0.69	0.50	1.63
0959810075	0.750	1.25	0.753	0.53	3.50	0.63	1.88	1.13	0.75	2.55
0959810100	1.000	1.50	1.003	0.66	4.50	0.88	2.38	1.37	1.00	3.25
0959810138	1.375	2.00	1.378	0.66	5.00	1.00 ⁷	3.00	1.88	1.38	3.82
0959810175	1.750	2.50	1.753	0.91	6.50	1.25 ⁷	3.38	2.13	1.75	4.95
0959810200	2.000	2.50	2.003	1.06	7.50	1.50	4.00	2.38	2.00	5.73
0959810250	2.500	3.00	2.503	1.19	8.50	1.75	4.75	2.88	2.50	6.58
0959810300	3.000	3.00	3.003	1.31	9.50	2.00	5.25	3.13	3.00	7.50
0959810350	3.500	4.00	3.503	1.81	12.63	2.50 ⁸	6.50 ⁸	3.88	3.50	9.62
0959810400	4.000	4.50	4.003	2.06	14.88	3.00 ⁸	7.50 ⁸	4.38	4.06	11.45

⁵ When used to mate with the Rod Clevis, select by pin diameter in the table above.

⁶ Eye Brackets with pin diameters 0.500 thru 1.000 are forged steel. Eye Brackets with 0.312 and 1.375 pin diameter and larger are cast ductile iron.

⁷ These dimensions vary from NFPA standard. F is increased by 0.13. Sufficient LR clearance remains for full swing arc with Miller cap clevis cylinders and rod clevises.

⁸ Mounting base thickness dimension F is increased on these sizes to provide greater load capacity than the former fabricated steel design. Cast ductile iron dimensions F and FL are 0.81 larger for 3.500 pin diameter and 1.06 larger for 4.000 pin diameter.

Miller AV Series Heavy-Duty Air Cylinders

Cylinder
Accessories

Rod End Accessories

Accessories offered for the rod end of the cylinder include Rod Clevis, Eye Bracket, Rod Eye, Clevis Bracket, and Pivot Pin. To select the proper part number for any desired accessory, refer to the table below or on the opposite page and look in the row to the right of the rod thread in the first column. For economical accessory selection, it is recommended that rod end style 2 be specified on your cylinder order.

Accessory Load Capacity

The various accessories have been load rated for your convenience. The load Capacity in lbs. is the recommended maximum load for that accessory based on a 4:1 design factor in tension. (Pivot Pin is rated in shear.) Before specifying, compare the actual load or the tension (pull) force at the maximum operating pressure of the cylinder with the load capacity of the accessory you plan to use. If load or pull force of cylinder exceeds load capacity of accessory, consult factory.

Thread Size	Pin Ø	Rod Eye		Clevis Bracket				Pivot Pin	
		Part Number	Load Capacity (lb)	Forged Steel or Cast Ductile Iron		Fabricated Steel		Part Number	Shear Capacity (lb)
				Part Number	Load Capacity (lb)	Part Number	Load Capacity (lb)		
5/16-24	0.438	0740750000	3300	0960160044	2830	0740760000	3600	0740780000	6600
7/16-20	0.500	0690890000	5000	0960160050	7740	0692050000	7300	0683680000	8600
1/2-20	0.500	0690900000	5700	0960160050	7740	0692050000	7300	0683680000	8600
3/4-16	0.750	0690910000	12100	0960160075	13600	0692060000	10880	0683690000	19300
7/8-14	1.000	0690920000	13000	0960160100	23000	0692070000	15180	0683700000	34300
1-14	1.000	0690930000	21700	0960160100	23000	0692070000	15180	0683700000	34300
1 1/4-12	1.375	0690940000	33500	0960160138	39500	0692080000	23560	0683710000	65000
1 1/2-12	1.750	0690950000	45000	0960160175	49480	0692090000	21520	0683720000	105200
1 3/4-12	2.000	0690960000	53500	0960160200	72400	0692100000	26000	0692150000	137400
1 7/8-12	2.000	0962160000	75000	0960160200	72400	0692100000	26000	0692150000	137400
2 1/4-12	2.500	0962170000	98700	0960160250	98700	0692110000	28710	0683740000	214700
2 1/2-12	3.000	0962180000	110000	0960160300	123300	0692120000	28190	0683750000	309200
2 3/4-12	3.000	0962190000	123300	N/A	N/A	0692130000	31390	0692160000	309200
3 1/4-12	3.500	0962200000	161300	0960160350	200400	0735420000	80250	0735450000	420900
3 1/2-12	3.500	0962210000	217300	0960160350	200400	0735420000	80250	0735450000	420900
4-12	4.000	0962220000	273800	0960160400	292100	0735430000	98420	0821810000	565800
N/A	4.000	N/A	N/A	N/A	N/A	N/A	N/A	0735470000 ¹	565800

¹ This size supplied with cotter pins.

Forged Steel or Cast Ductile Iron Clevis Bracket Dimensions

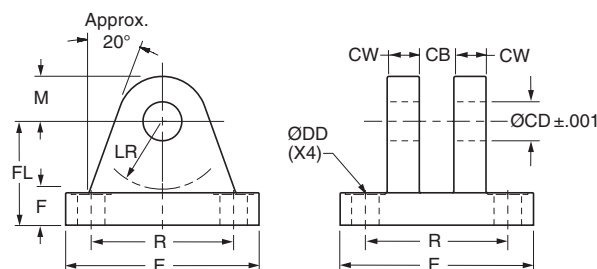

Cast or Forged ² Part Number	Pin Ø	CB	CD Ø	CW	DD Ø	E (As Cast)	F	FL	LR	M (As Cast)	R
0960160044	0.438	0.46	0.440	0.37	0.27	2.25	0.38	1.00	0.56	0.44	1.75
0960160050	0.500	0.78	0.503	0.50	0.41	2.50	0.38	1.13	0.63	0.56	1.63
0960160075	0.750	1.28	0.753	0.63	0.53	3.50	0.63	1.88	1.06	0.75	2.56
0960160100	1.000	1.53	1.003	0.75	0.66	4.50	0.75	2.25	1.25	1.00	3.25
0960160138	1.375	2.03	1.378	1.00	0.66	5.00	0.88	3.00	1.94	1.38	3.81
0960160175	1.750	2.53	1.753	1.25	0.91	6.50	0.94	3.13	2.00	1.75	4.94
0960160200	2.000	2.53	2.003	1.25	1.06	7.50	1.38	3.75	2.25	2.00	5.75
0960160250	2.500	3.03	2.503	1.50	1.19	8.50	1.50	4.50	2.81	2.50	6.59
0960160300	3.000	3.03	3.003	1.50	1.31	9.50	1.88	5.38	3.31	3.00	7.50
0960160350	3.500	4.03	3.503	2.00	1.81	12.63	2.31	6.38	3.88	3.50	9.62
0960160400	4.000	4.53	4.003	2.25	2.06	14.88	2.88	7.50	4.50	4.00	11.50

² Clevis Brackets with pin diameters 0.500 thru 1.000 are forged steel. Clevis Brackets with 0.438 and 1.375 pin diameter and larger are cast ductile iron.

Miller AV Series Heavy-Duty Air Cylinders

Cylinder
Accessories

Rod Eye Dimensions

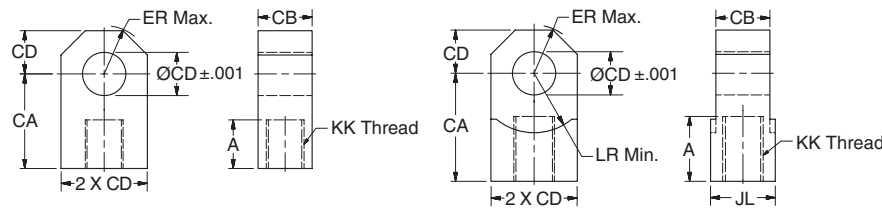

Thread Size thru 1 3/4-12

Thread Size 1 7/8-12 & Larger

Part Number	Pin Ø	A	CA	CB	CD Ø	ER	JL	LR min	KK Thread
0740750000	0.438	0.75	1.50	0.43	0.440	0.53	-	-	5/16-24
0690890000	0.500	0.75	1.50	0.75	0.503	0.59	-	-	7/16-20
0690900000	0.500	0.75	1.50	0.75	0.503	0.59	-	-	1/2-20
0690910000	0.750	1.13	2.06	1.25	0.753	0.87	-	-	3/4-16
0690920000	1.000	1.13	2.38	1.50	1.003	1.15	-	-	7/8-14
0690930000	1.000	1.63	2.81	1.50	1.003	1.15	-	-	1-14
0690940000	1.375	2.00	3.44	2.00	1.378	1.55	-	-	1 1/4-12
0690950000	1.750	2.25	4.00	2.50	1.753	1.96	-	-	1 1/2-12
0690960000	2.000	2.25	4.38	2.50	2.003	2.24	-	-	1 3/4-12
0962160000	2.000	3.00	5.00	2.50	2.003	2.24	3.00	2.77	1 7/8-12
0962170000	2.500	3.50	5.81	3.00	2.503	2.76	3.50	3.09	2 1/4-12
0962180000	3.000	3.50	6.13	3.00	3.003	3.30	4.00	3.58	2 1/2-12
0962190000	3.000	3.63	6.50	3.50	3.003	3.30	4.00	3.58	2 3/4-12
0962200000	3.500	4.50	7.63	4.00	3.503	3.87	6.00	4.18	3 1/4-12
0962210000	3.500	5.00	7.63	4.00	3.503	3.87	6.00	4.18	3 1/2-12
0962220000	4.000	5.50	9.13	4.50	4.003	4.43	6.00	4.80	4-12

Pivot Pin Dimensions

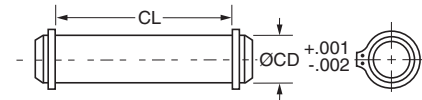

Part Number	CD Ø	CL
0740780000	0.438	1.31
0683680000	0.500	1.88
0683690000	0.750	2.63
0683700000	1.000	3.13
0683710000	1.375	4.19
0683720000	1.750	5.19
0692150000	2.000	5.69
0683740000	2.500	6.19
0683750000	3.000	6.25
0692160000	3.000	6.75
0735450000	3.500	8.25
0821810000	4.000	8.69
0735470000 ¹	4.000	9.00

¹This size supplied with cotter pins.

Notes:

- Pivot Pins are furnished with Clevis Mounted Cylinders as standard.
- Pivot Pins are furnished with (2) Retainer Rings.
- Pivot Pins must be ordered as a separate item if to be used with Rod Eyes, Rod Clevises, or Clevis Brackets.

Fabricated Steel Clevis Bracket Dimensions

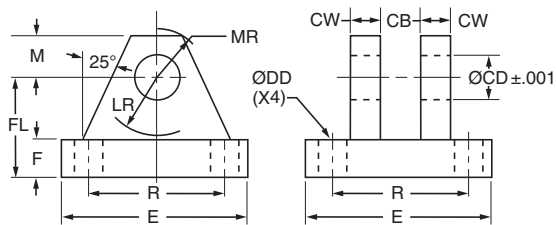

Fabricated Steel Part Number	Pin ² Ø	CB	CD Ø	CW	DD Ø	E	F	FL	LR	M	MR	R
0692050000	0.500	0.80	0.503	0.50	0.41	3.50	0.50	1.50	0.75	0.50	0.63	2.55
0692060000	0.750	1.30	0.753	0.63	0.53	5.00	0.63	1.88	1.19	0.75	0.91	3.82
0692070000	1.000	1.59	1.003	0.75	0.66	6.50	0.75	2.25	1.50	1.00	1.25	4.95
0692080000	1.375	2.09	1.378	1.00	0.66	7.50	0.88	3.00	2.00	1.38	1.66	5.73
0692090000	1.750	2.59	1.753	1.25	0.91	9.50	0.88	3.63	2.75	1.75	2.22	7.50
0692100000	2.000	2.59	2.003	1.50	1.06	12.75	1.00	4.25	3.19	2.25	2.78	9.40
0692110000	2.500	3.09	2.503	1.50	1.19	12.75	1.00	4.50	3.50	2.50	3.13	9.40
0692120000	3.000	3.09	3.003	1.50	1.31	12.75	1.00	6.00	4.25	3.00	3.59	9.40
0692130000	3.000	3.59	3.003	1.50	1.31	12.75	1.00	6.00	4.25	3.00	3.59	9.40
0735420000	3.500	4.09	3.503	2.00	1.81	15.50	1.69	6.69	5.00	3.50	4.13	12.00
0735430000	4.000	4.59	4.003	2.00	2.06	17.50	1.94	7.69	5.75	4.00	4.88	13.75

² Clevis Bracket for 0.438 diameter pin is only available in cast ductile iron construction. See part number 0960160044 on previous page.

Miller AV Series Heavy-Duty Air Cylinders

Piston Rod End
"Style 9"

Miller "Style 9" Piston Rod End Split Flange Coupling Rod End

- Simplifies alignment
- Reduces assembly time
- Available in 5/8" through 5-1/2" piston rod diameters

Style 9 Rod End

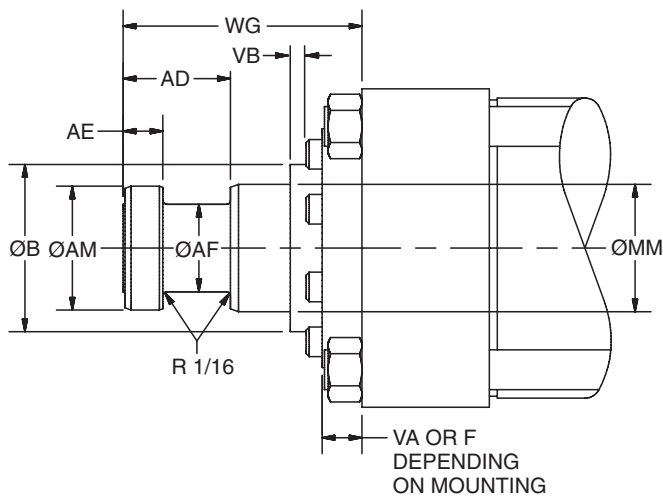

Dimensions Style 9 Rod End

MM Rod Ø	AD	AE	AF Ø	AM Ø	WG
5/8	5/8	1/4	3/8	.57	1 3/4
1	15/16	3/8	11/16	.95	2 3/8
1 3/8	1 1/16	3/8	7/8	1.32	2 3/4
1 3/4	1 5/16	1/2	1 1/8	1.70	3 1/8
2	1 11/16	5/8	1 3/8	1.95	3 3/4
2 1/2	1 15/16	3/4	1 3/4	2.45	4 1/2
3	2 7/16	7/8	2 1/4	2.95	5
3 1/2	2 11/16	1	2 1/2	3.45	5 5/8
4	2 11/16	1	3	3.95	5 3/4
5	3 3/16	1 1/2	3 7/8	4.95	6 5/8
5 1/2	3 15/16	1 7/8	4 3/8	5.45	7 1/2

See previous catalog pages for B, F, G, VA, and VB per bore and rod diameter.

Miller AV Series Heavy-Duty Air Cylinders

Piston Rod End
"Style 9"

"Style 9" Piston Rod End Split Couplers and Weld Plates

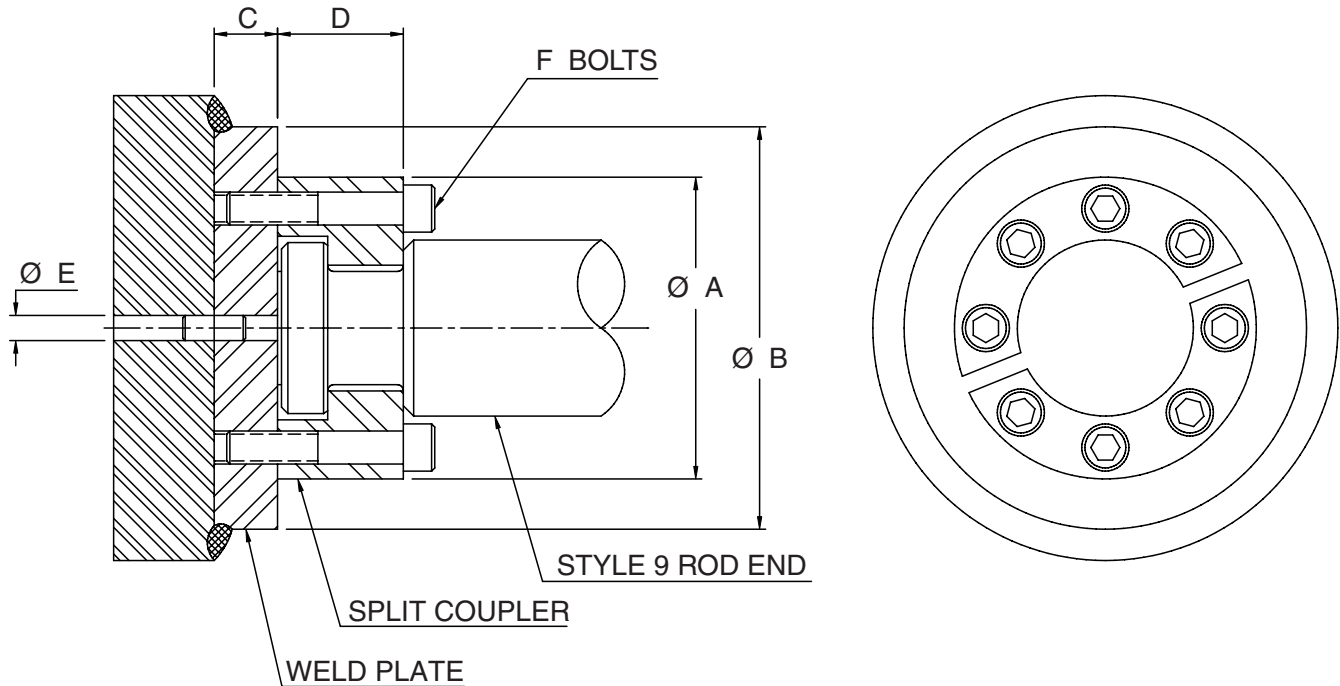

⚠ WARNING: Piston rod separation from the machine member can result in severe personal injury or even death to nearby personnel. The cylinder user must make sure the weld holding the weld plate to the machine is of sufficient quality and size to hold the intended load. The cylinder user must also make sure the bolts holding split coupler to the weld plate are of sufficient strength to hold the intended load and installed in such a way that they will not become loose during the machine's operation.

Table 1 — Part Numbers and Dimensions

ROD Ø	A Ø	B Ø	C	D	E Ø	F	BOLT SIZE	BOLT CIRCLE	SPLIT COUPLER PART NO.	WELD PLATE PART NO.
.625	1.50	2.00	.50	.56	.250	4	#10-24 x .94 LG	1.125	1472340062	1481740062
1.00	2.00	2.50	.50	.88	.250	6	.250-20 x 1.25 LG	1.500	1472340100	1481740100
1.375	2.50	3.00	.63	1.00	.250	6	.312-18 x 1.50 LG	2.000	1472340138	1481740138
1.75	3.00	4.00	.63	1.25	.250	8	.312-18 x 1.75 LG	2.375	1472340175	1481740175
2.00	3.50	4.00	.75	1.63	.375	12	.375-16 x 2.25 LG	2.687	1472340200	1481740200
2.50	4.00	4.50	.75	1.88	.375	12	.375-16 x 2.50 LG	3.187	1472340250	1481740250
3.00	5.00	5.50	1.00	2.38	.375	12	.500-13 x 3.25 LG	4.000	1472340300	1481740300
3.50	5.88	7.00	1.00	2.63	.375	12	.625-11 x 3.50 LG	4.687	1472340350	1481740350
4.00	6.38	7.00	1.00	2.63	.375	12	.625-11 x 3.50 LG	5.187	1472340400	1481740400
5.00	7.38	8.00	1.00	3.13	.375	12	.625-11 x 4.00 LG	6.187	1472340500	1481740500
5.50	8.25	9.00	1.25	3.88	.375	12	.750-10 x 5.00 LG	6.875	1472340550	1481740550

Note: Screws are not included with split coupler or weld plate.

Miller AV Series Heavy-Duty Air Cylinders

Linear Alignment
Couplers

Linear Alignment Couplers are available in 13 standard thread sizes...

Cost Saving Features and Benefits Include...

- Maximum reliability for trouble-free operation, long life and lower operating costs
- Increased cylinder life by reducing wear on piston and rod bearings
- Simplifying cylinder installation and reducing assembly costs
- Increase rod bearing and rod seal life for lower maintenance costs

Alignment Coupler

See Table 1 for Part Numbers and Dimensions

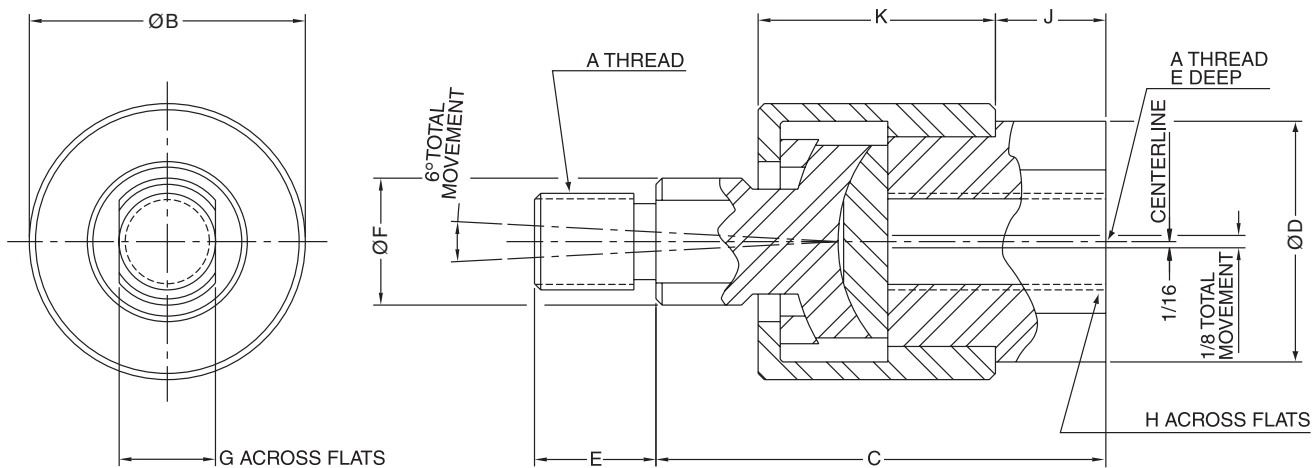

Table 1 — Part Numbers and Dimensions

Part No.	A	B Ø	C	D Ø	E	F Ø	G	H	J	K	Max. Pull Load (lbs.)	Approx. Weight (lbs.)
1347570031	5/16-24	1 1/8	1 3/4	15/16	1/2	1/2	3/8	3/4	3/8	15/16	1200	.35
1347570038	3/8-24	1 1/8	1 3/4	15/16	1/2	1/2	3/8	3/4	3/8	15/16	2425	.35
1347570044	7/16-20	1 3/8	2	1 1/8	3/4	5/8	1/2	7/8	3/8	1 3/32	3250	.55
1347570050	1/2-20	1 3/8	2	1 1/8	3/4	5/8	1/2	7/8	3/8	1 3/32	4450	.55
1347570063	5/8-18	1 3/8	2	1 1/8	3/4	5/8	1/2	7/8	3/8	1 3/32	6800	.55
1347570075	3/4-16	2	2 5/16	1 5/8	1 1/8	15/16	3/4	1 5/16	7/16	1 9/32	9050	1.4
1347570088	7/8-14	2	2 5/16	1 5/8	1 1/8	15/16	3/4	1 5/16	7/16	1 9/32	14450	1.4
1347570100	1-14	3 1/8	3	2 3/8	1 5/8	1 7/16	1 1/4	1 7/8	3/4	1 25/32	19425	4.8
1347570125	1 1/4-12	3 1/8	3	2 3/8	1 5/8	1 7/16	1 1/4	1 7/8	3/4	1 25/32	30500	4.8
1337390125	1 1/4-12	3 1/2	4	2	2	1 1/2	1 1/4	1 11/16	3/4	2 1/2	30500	6.9
1337390150	1 1/2-12	4	4 3/8	2 1/4	2 1/4	1 3/4	1 1/2	1 15/16	7/8	2 3/4	45750	9.8
1337390175	1 3/4-12	4	4 3/8	2 1/4	2 1/4	1 3/4	1 1/2	1 15/16	7/8	2 3/4	58350	9.8
1337390188	1 7/8-12	5	5 5/8	3	3	2 1/4	1 15/16	2 5/8	1 3/8	3 3/8	67550	19.8

How to Order Linear Alignment Couplers — When ordering a cylinder with a threaded male rod end, specify the coupler of equal thread size by part number as listed in Table 1, i.e.; Piston Rod “KK” dimension is 3/4" - 16", specify coupler part number 1347570075.

Miller AV Series Heavy-Duty Air Cylinders

Dual Axis
Knuckle

Dual Axis Knuckle

Using a Dual Axis Knuckle permits increased angular movement from the cylinder center line. Clevis or Eye mounted cylinders often require movement beyond the plane that two pivot pins allow. Spherical bearing mounts permit angular movement up to 4.5° within the pivoting plane. A Dual Axis Knuckle, with two pin holes 90° apart, installed at the cap and rod end of a Model 84 cylinder adds two pivot points, thereby providing up to 30° movement in another plane at each end.

Dual Axis Knuckle Benefits

- Increased angular movement range compared to spherical bearing mount.
- Significantly higher dynamic load rating than spherical bearing mount.
- Reduced bearing loads and wear that results from misalignment.
- Allows faster assembly of pivoting cylinders to the machine.

Maximum Achievable Angular Movement from Cylinder Centerline*

Inboard Pin -

15° maximum movement for cylinder misalignment only.

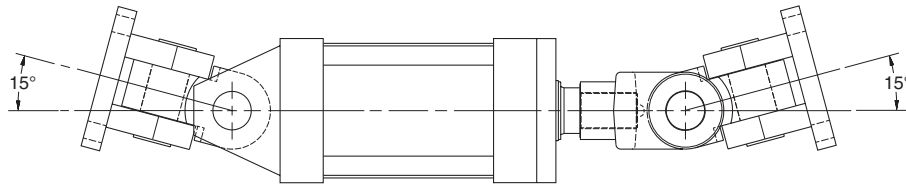

Outboard Pin -

30° maximum movement when applying force to a load moving in a curved plane.

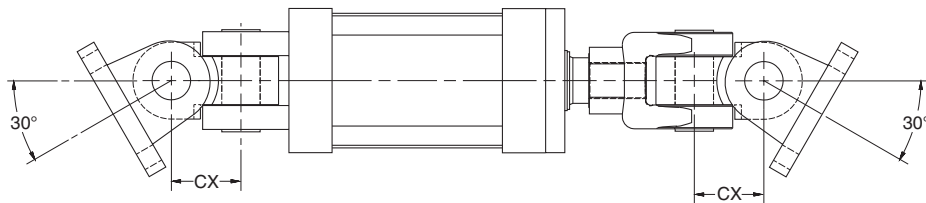

*Maximum movement is achieved with cast clevis brackets. Movement is reduced when using fabricated clevis brackets.

Dual Axis Knuckle Dimensions and Usage

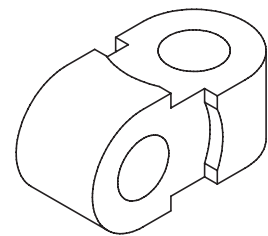
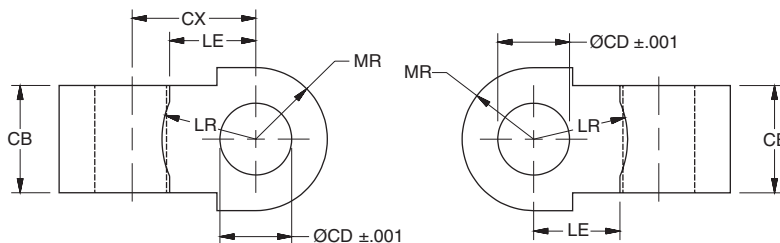

Part Number	Pin Ø	Load Capacity (lb)	CB	CD Ø	CX	LE	LR	MR	Mating Parts		Model 84 Usage by Bore
									Clevis Bracket	Rod Clevis	
0952670000	0.500	4380	0.75	0.503	0.88	0.54	0.63	0.50	0960160050	0509400000, 0509410000	1.50, 2.00, 2.50
0952680000	0.750	12370	1.25	0.753	1.19	0.80	0.94	0.75	0960160075	0509420000, 1332840000	3.25, 4.00, 5.00
0952690000	1.000	20500	1.50	1.003	1.69	1.05	1.22	1.00	0960160100	0509430000, 0509440000, 1332850000	6.00, 7.00, 8.00
0952700000	1.375	30500	2.00	1.378	2.38	1.44	1.69	1.38	0960160138	0509450000, 1332860000	10.00
0952710000	1.750	49500	2.50	1.753	3.06	1.81	2.19	1.75	0960160175	0509460000	12.00
0952720000	2.000	68000	2.50	2.003	3.63	2.09	2.44	2.00	0960160200	0509470000, 0509480000	14.00

Miller AV Series Heavy-Duty Air Cylinders

Push and Pull Forces

Theoretical Push and Pull Forces Push Force and Displacement

Cyl. Bore Size (Inches)	Piston Area (Sq. In.)	Cylinder Push Stroke Force In Pounds At Various Pressures						Cu. Ft. Free Air At 80 Lbs. Pressure, Required To Move Max. Load 1 Inch
		25	50	65	80	100	250	
1	.785	20	39	51	65	79	196	.00293
1½	1.767	44	88	115	142	177	443	.00659
2	3.14	79	157	204	251	314	785	.01171
2½	4.91	123	245	319	393	491	1228	.01830
3¼	8.30	208	415	540	664	830	2075	.03093
4	12.57	314	628	817	1006	1257	3143	.04685
5	19.64	491	982	1277	1571	1964	4910	.07320
6	28.27	707	1414	1838	2262	2827	7068	.10541
7	38.49	962	1924	2502	3079	3849	9623	.14347
8	50.27	1257	2513	3268	4022	5027	12568	.18740
10	78.54	1964	3927	5105	6283	7854	19635	.29280
12	113.10	2828	5655	7352	9048	11310	28275	.42164
14	153.94	3849	7697	10006	12315	15394	38485	.57389

Deductions for Pull Force and Displacement

Piston Rod Ø (Inches)	Piston Area (Sq. In.)	Piston Rod Diameter Force In Pounds At Various Pressures						Cu. Ft. Free Air At 80 Lbs. Pressure, Required To Move Max. Load 1 Inch
		25	50	65	80	100	250	
To determine Cylinder Pull Force or Displacement, deduct the following Force or Displacement corresponding to Rod Size, from selected Push Stroke Force or Displacement corresponding to Bore Size in table above.								
½	.196	5	10	13	16	20	49	.00073
5/8	.307	8	15	20	25	31	77	.00114
1	.785	20	39	51	65	79	196	.00293
1⅜	1.49	37	75	97	119	149	373	.00554
1¾	2.41	60	121	157	193	241	603	.00897
2	3.14	79	157	204	251	314	785	.01171
2½	4.91	123	245	319	393	491	1228	.01830
3	7.07	177	354	460	566	707	1767	.02635
3½	9.62	241	481	625	770	962	2405	.03587
4	12.57	314	628	817	1006	1257	3143	.04685
4½	15.90	398	795	1033	1272	1590	3975	.05929
5	19.64	491	982	1277	1571	1964	4910	.07320
5½	23.76	594	1188	1544	1901	2376	5940	.08857

General Formula

The cylinder output forces are derived from the formula:

$$F = P \times A$$

Where F = Force in pounds.
P = Pressure at the cylinder in pounds per square inch, gauge.
A = Effective area of cylinder piston in square inches.

Free Air refers to normal atmospheric conditions of the air at sea level (14.7 psi). Use above cu. ft. free air required data to

compute CFM required from a compressor at 80 psi. cu. ft. of free air required at other pressures can be calculated using formula below.

$$V^1 = \frac{(P^2 + 14.7) V^2}{14.7}$$

Where V¹ = Free air consumption per inch of stroke (cubic feet).

V² = Cubic feet displaced per inch of stroke.

P² = Gauge pressure required to move maximum load.

Miller AV Series Heavy-Duty Air Cylinders

Operating Fluids and Temperature Range

AV Series cylinders are equipped with seals for use with lubricated air. In some cases special seals are required.

Class 1 Seals

Class 1 seals are the standard seals provided in a cylinder assembly. They are intended for use with fluids such as: air, nitrogen, mineral base hydraulic oil or MIL-H-5606 within the temperature range of -10°F (-23°C) to +165°F (+74°C). The individual seals may be nitrile (Buna-N), enhanced polyurethane, polymyte, PTFE or filled PTFE.

Class 4 Seals — Nitrile Seals

Class 4 seals are intended for low temperature service with the same type of fluids as used with Class 1 seals within the temperature range of -50°F (-46°C) to +150°F (+66°C). Class 4 seals are nitrile seals. Lipseals will have leather, polymyte or PTFE back-up washers when required. O-rings will have nitrile back-up washers when required.

Note: Certain fluids may react adversely with Class 4 seals compared to Class 1 seals.

Class 5 Seals — Fluorocarbon Seals

Class 5 seals are intended for elevated temperature service. Note: In addition, Class 5 seals can be used with fluids listed below under Class 1 service. Class 5 seals can operate with a temperature range of -10°F (-23°C) to +250°F (+121°C). Fluorocarbon seals may be operated to +400°F (+204°C) with limited service life. For temperatures above +250°F (+121°C) the cylinder must be manufactured with non-studded piston rod thread and a pinned piston to rod connection. Class 5 seals are fluorocarbon seals. Lipseals will have PTFE back-up washers when required. O-rings will have fluorocarbon back-up when required.

Lipseal Pistons

Under most conditions lipseals provide the best all around service for pneumatic applications. Lipseals with a back-up washers are often used for hydraulic applications when virtually zero static leakage is required. Lipseals will function properly in these applications when used in conjunction with moderate hydraulic pressures.

Warning!

The piston rod stud and the piston rod to piston threaded connections are secured with an anaerobic adhesive which is temperature sensitive. Cylinders specified with fluorocarbon seals are assembled with anaerobic adhesive having a maximum temperature rating of +250°F (+121°C). Cylinders specified with all other seal compounds are assembled with anaerobic adhesive have a maximum operating temperature rating +165°F (+74°C). These temperature limitations are necessary to prevent the possible loosening of the threaded connections. Cylinders originally manufactured with Class 1 seals (Nitrile) that will be exposed to ambient temperatures above +165°F (+74°C) must be modified for higher temperature service. Contact the factory immediately and arrange for the piston to rod and the stud to piston rod connections to be properly reassembled to withstand the higher temperature service.

Class No.	Typical Fluids	Temperature Range
1 Standard Nitrile Polyurethane	Air, Nitrogen Hydraulic Oil, Mil-H-5606 Oil	-10°F (-23°C) to +165°F (+74°C)
4 Special (Nitrile) (At extra cost)	Low Temperature Air	-50°F (-46°C) to +150°F (+66°C)
5 Optional (At extra cost) (Fluorocarbon Seals)	High Temperature	See above paragraph on Fluorocarbon seals for recommended temperature range.

Miller AV Series Heavy-Duty Air Cylinders

Ports

Miller AV Series pneumatic cylinders are supplied with NPTF pipe thread ports. If specified on your order, extra ports can be provided on the sides of heads or caps that are not occupied by mountings or cushion valve.

Standard port location is position 1 as shown on line drawings in product catalog and Figure 1 below. Cushion adjustment needle and check valves are at position 2 (or 3), depending on mounting style. Heads or caps which do not have an integral mounting can be rotated and assembled with ports at 90° or 180° from standard position. Mounting styles on which head or cap can be rotated at no extra charge are shown in Table A below. To order, specify by position number. In such assemblies the cushion adjustment needle and check valve rotate accordingly since their relationship with port position does not change.

Figure 1

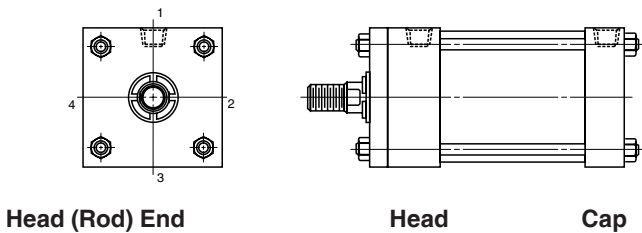

Table A

Model	Port Position Available	
	Head End	Cap End
51, 52, 53, 61, 62, 63, 64, 65, 66, 89	1, 2, 3 or 4	1, 2, 3 or 4
82, 84	1,2, 3 or 4	1 or 3
81	1 or 3	1, 2, 3 or 4
72, 74	1	1

Ports can be supplied at positions other than those shown in Table A at an extra charge. To order, specify port position as shown in Figure 1.

International Ports

Other port configurations to meet international requirements are available at extra cost. Miller AV Series cylinders can be supplied, on request, with British standard taper port (BSPT). Such port has a taper of 1 in 16 measured on the diameter (1/16" per inch). The thread form is Whitworth System, and size and number of threads per inch are as follows:

Table B
British Standard Pipe Threads

Nominal Pipe Size	No. Threads Per Inch	Pipe O.D.
1/8	28	.383
1/4	19	.518
3/8	19	.656
1/2	14	.825
3/4	14	1.041
1	11	1.309
1 1/4	11	1.650
1 1/2	11	1.882
2	11	2.347

British standard parallel internal threads are designated as BSPP and have the same thread form and number of threads per inch as the BSPT type and can be supplied, on request, at extra cost. Unless otherwise specified, the BSPP or BSPT port size supplied will be the same nominal pipe size as the NPTF port for a given bore size cylinder.

Metric ports can also be supplied to order at extra cost. Consult factory.

Oversize Ports

Oversize NPTF ports can be provided, at an extra charge. For ports one size larger than standard, welded port bosses which protrude from the side of the head or cap are supplied. For dimensions, see drawing below and table.

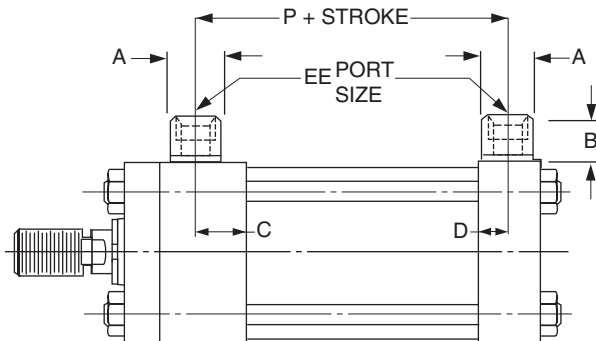

Oversize NPTF Port Boss Dimensions

Bore	EE (NPTF)	A Ø	B	C	D	P
1	3/8	7/8	3/4	9/16	1/2	2 1/16
1 1/2	1/2	1 1/8	15/16	9/16	1/2	2 3/16
2	1/2	1 1/8	15/16	9/16	1/2	2 3/16
2 1/2	1/2	1 1/8	15/16	9/16	1/2	2 5/16
3 1/4	3/4	1 3/8	1	1 1/16	5/8	2 9/16
4	3/4	1 3/8	1	1 1/16	5/8	2 9/16
5	3/4	1 3/8	1	1 1/16	5/8	2 13/16
6	1	1 3/4	1 3/16	15/16	3/4	3 3/16
7-8	1	1 3/4	1 3/16	15/16	3/4	3 5/16
10	1 1/4	2 1/4	1 5/16	1 1/8	1	4 1/4
12	1 1/4	2 1/4	1 5/16	1 1/8	1	4 3/4
14	1 1/2	2 1/2	1 9/16	1 1/4	1 1/8	5 1/2

Miller AV Series Heavy-Duty Air Cylinders

Stroke Tolerance
Cylinder Weights

Stroke Tolerance

Stroke length tolerances are required due to buildup of tolerances of piston, head, cap and cylinder body. Standard production stroke tolerances run $+1/32''$ to $-1/64''$ up to 20" stroke, $+1/32''$ to $-.20''$ for 21" to 60" and $+1/32''$ to $-1/32''$ for greater than 60" stroke. For closer tolerances on stroke length, it is necessary to specify the required tolerance plus the operating pressure

and temperature at which the cylinder will operate. Stroke tolerances smaller than $.015''$ are not generally practical due to elasticity of cylinders. If machine design requires such close tolerances, use of a stroke adjuster may achieve the desired result.

Cylinder Weights

The weights shown in Table A are for Miller Series AV and AVN cylinders with various piston rod diameters. To determine the net weight of a cylinder, first select the proper basic weight for zero stroke, then calculate the weight of the cylinder stroke and add the result to the basic weight. For extra rod extension,

use piston rod weights per inch shown in Table B. Weights of cylinders with intermediate rods may be estimated from table below by taking the difference between the piston rod weights per inch and adding it to the standard rod diameter weight for the cylinder bore size involved.

Table A Cylinder Weights, in pounds, for AV & AVN Series cylinders

Bore Size	Rod Ø	Single Rod Cylinders Basic Wt. Zero Stroke		Add Per Inch of Stroke	Double Rod Cylinders Basic Wt. Zero Stroke		Add Per Inch of Stroke
		51, 52, 53, 61, 62, 63, 64, 74	65, 66, 72, 81, 82, 84, 89, 94		D51, D53, D61, D74	D61, D72, D81, D89	
1"	1/2"	2.5	2.9	.20	4.7	5.5	.40
	5/8"	2.6	3.0	.23	4.9	5.7	.46
1 1/2"	5/8"	3.7	4.3	.3	4.2	4.8	.6
	1"	4.5	5.1	.4	5.8	6.7	.8
2"	5/8"	6.5	6.9	.5	8.2	8.6	1.0
	1"	7.0	7.5	.63	9.0	9.5	1.3
	1 3/8"	8.5	8.9	.8	11.2	11.6	1.6
2 1/2"	5/8"	9.0	9.7	.6	11.4	12.1	1.2
	1"	9.5	10.0	.73	12.0	12.5	1.5
	1 3/4"	13.2	13.6	1.1	19.8	20.5	2.2
3 1/4"	1"	16.5	17.5	.8	22.0	23.0	1.6
	1 3/8"	17.0	18.0	1.0	22.5	23.5	2.0
	2"	27.0	28.0	1.4	43.0	44.0	2.8
4"	1"	26.0	31.0	1.0	33.0	38.0	2.0
	1 3/8"	26.5	31.5	1.2	33.5	38.5	2.5
	2 1/2"	36.0	42.0	2.0	53.0	58.0	4.0
5"	1"	39.0	46.0	1.1	48.0	55.0	2.2
	1 3/8"	39.5	46.5	1.3	48.5	55.5	2.6
	3 1/2"	63.0	66.0	3.6	96.0	103.0	7.2
6"	1 3/8"	68.0	77.0	1.5	80.0	89.0	3.0
	4"	100.0	102.0	4.5	144.0	153.0	9.0
7"	1 3/8"	80.0	85.0	2.0	92.0	97.0	4.0
	2"	82.0	87.0	3.5	96.0	101.0	7.0
8"	1 3/8"	94.0	99.0	2.0	108.0	113.0	4.0
	5 1/2"	168.0	172.0	8.0	256.0	261.0	16.0
10"	1 3/4"	182.0	188.0	2.5	178.0	184.0	5.0
	5 1/2"	258.0	264.0	8.5	330.0	335.0	17.0
12"	2"	274.0	282.0	3.5	270.0	280.0	7.0
	5 1/2"	350.0	358.0	9.5	420.0	430.0	19.0
14"	2 1/2"	435.0	448.0	4.5	440.0	655.0	9.0
	5 1/2"	510.0	519.0	10.0	490.0	705.0	20.0

Table B

Rod Ø	Piston Rod Wt. Per Inch	Rod Ø	Piston Rod Wt. Per Inch	Rod Ø	Piston Rod Wt. Per Inch
5/8"	.09	2"	.89	4"	3.56
1"	.22	2 1/2"	1.40	4 1/2"	4.51
1 3/8"	.42	3"	2.00	5"	5.56
1 3/4"	.68	3 1/2"	2.72	5 1/2"	6.72

Miller AV Series Heavy-Duty Air Cylinders

Stop Tubing
Mounting Classes

Stop Tubing

Stop tube is recommended to lengthen the distance between the bushing and piston to reduce bearing loads when the cylinder is fully extended. This is especially true of horizontally mounted and long stroke cylinders. Long stroke cylinders achieve additional stability through the use of a stop tube.

When specifying cylinders with long stroke and stop tube, be sure to call out the net stroke and the length of the stop tube. Machine design can be continued without delay by laying in a cylinder equivalent in length to the NET STROKE PLUS STOP TUBE LENGTH, which is referred to as GROSS STROKE.

Drawing A

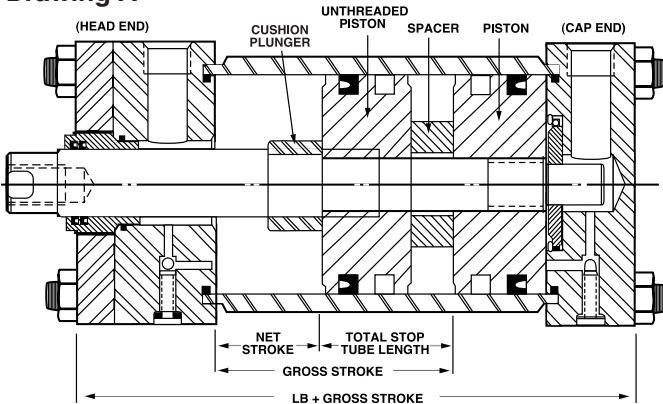

Double piston design is supplied on air cylinders with cushion head end or both ends.

Drawing B

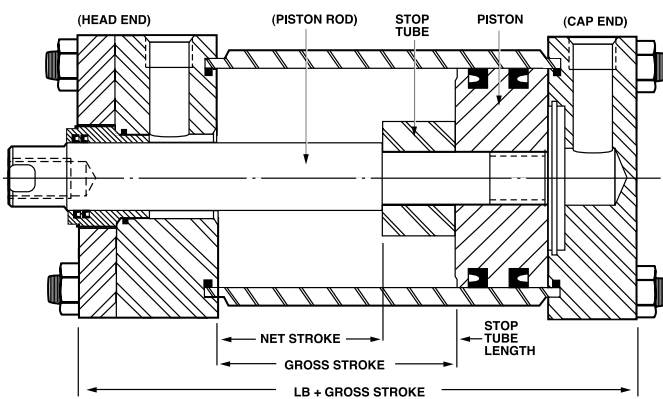

This design is supplied on all non-cushion cylinders.

Mounting Classes

Standard mountings for fluid power cylinders fall into three basic groups. The groups can be summarized as follows:

Group 1 Straight Line Force Transfer with fixed mounts which absorb force on cylinder centerline.

Group 2 Pivot Force Transfer. Pivot mountings permit a cylinder to change its alignment in one plane.

Group 3 Straight Line Force Transfer with fixed mounts which do not absorb force on cylinder centerline.

Because a cylinder's mounting directly affects the maximum pressure at which the cylinder can be used, the chart below should be helpful in selection of the proper mounting combination for your application. Stroke length, piston rod connection to load, extra piston rod length over standard, etc., should be considered for thrust loads. Alloy steel mounting bolts are recommended for all mounting styles, and thrust keys are recommended for Group 3.

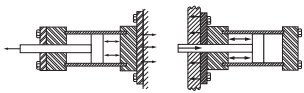
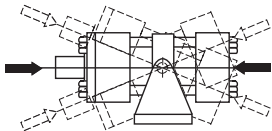
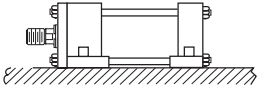
Group 1 FIXED MOUNTS which absorb force on cylinder centerline.	
<p>Heavy-Duty Service For Thrust Loads For Tension Loads</p>	 <p>Model 52 Model 53</p>
<p>Medium-Duty Service For Thrust Loads For Tension Loads</p>	<p>Models 62, 66 Models 61, 65</p>
<p>Light-Duty Service For Thrust Loads For Tension Loads</p>	<p>Model 62 Model 61</p>
Group 2 PIVOT MOUNTS which absorb force on cylinder centerline.	
<p>Heavy-Duty Service For Thrust Loads For Tension Loads</p>	 <p>Models 81, 89 Models 81, 82, 84, 89</p>
<p>Medium-Duty Service For Thrust Loads For Tension Loads</p>	<p>Model 84 Model 84</p>
Group 3 FIXED MOUNTS which do not absorb force on the centerline.	
<p>Heavy-Duty Service For Thrust Loads For Tension Loads</p>	 <p>Model 72 Model 72</p>
<p>Medium-Duty Service For Thrust Loads For Tension Loads</p>	<p>Model 74 Model 74</p>

Miller AV Series Heavy-Duty Air Cylinders

Piston Rod
Selection Chart and Data

Piston Rod — Stroke Selection Chart

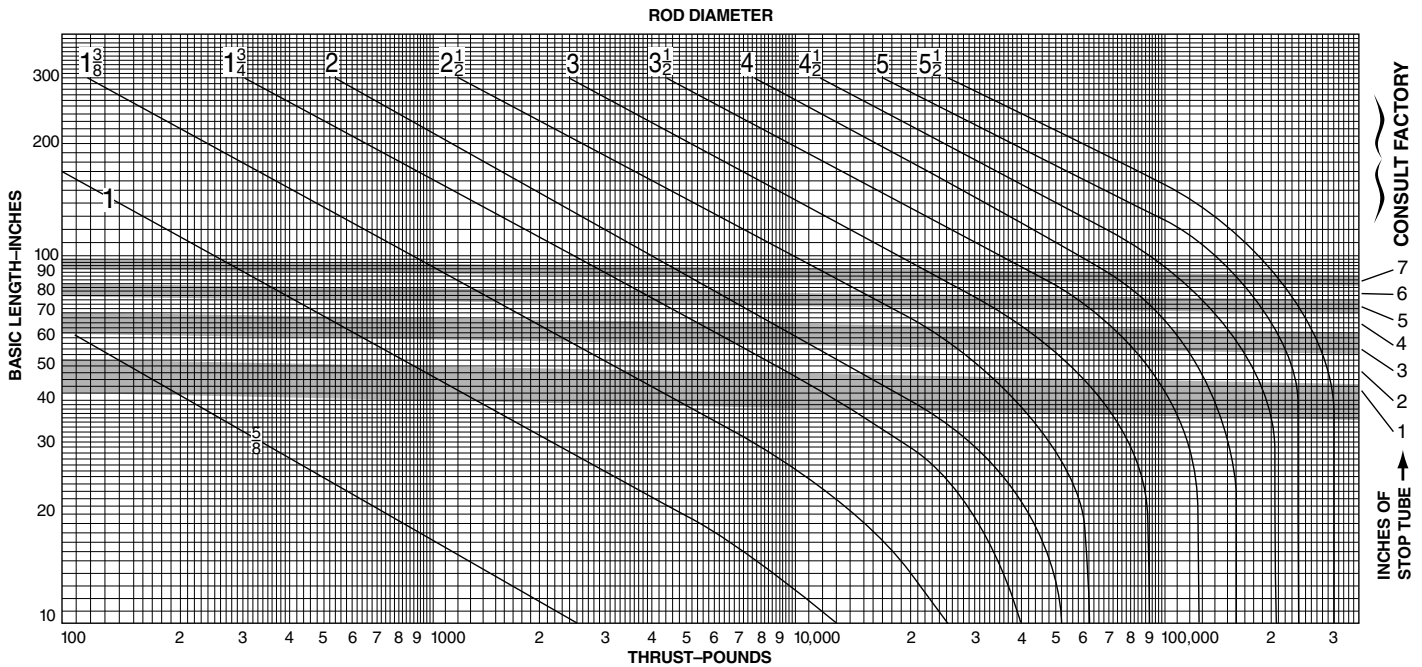

How to Use the Chart

The selection of a piston rod for thrust (push) conditions requires the following steps:

- Determine the type of cylinder mounting style and rod end connection to be used. Then consult the chart below and find the "stroke factor" that corresponds to the conditions used.
- Using this stroke factor, determine the "basic length" from the equation:

$$\text{Basic Length} = \frac{\text{Actual Stroke}}{\text{Stroke Factor}}$$

The graph is prepared for standard rod extensions beyond the face of the gland retainers. For rod extensions greater than standard, add the increase to the stroke in arriving at the "basic length."

- Find the load imposed for the thrust application by multiplying the full bore area of the cylinder by the system pressure.
- Enter the graph along the values of "basic length" and "thrust" as found above and note the point of intersection:

- The correct piston rod size is read from the diagonally curved line labeled "Rod Diameter" next above the point of intersection.
- The required length of stop tube is read from the right of the graph by following the shaded band in which the point of intersection lies.
- If required length of stop tube is in the region labeled "consult factory," submit the following information for an individual analysis:
 - Cylinder mounting style.
 - Rod end connection and method of guiding load.
 - Bore, required stroke, length of rod extension (Dim. "LA") if greater than standard, and series of cylinder used.
 - Mounting position of cylinder. (Note: If at an angle or vertical, specify direction of piston rod.)
 - Operating pressure of cylinder if limited to less than standard pressure for cylinder selected.

Recommended Mounting Styles for Maximum Stroke and Thrust Loads	Rod End Connection	Case	Stroke Factor
Groups 1 or 3 Long stroke cylinders for thrust loads should be mounted using a heavy-duty mounting style at one end, firmly fixed and aligned to take the principal force. Additional mounting should be specified at the opposite end, which should be used for alignment and support. An intermediate support may also be desirable for long stroke cylinders mounted horizontally. Machine mounting pads can be adjustable for support mountings to achieve proper alignment.	Fixed and Rigidly Guided	I	.50
	Pivoted and Rigidly Guided	II	.70
	Supported but not Rigidly Guided	III	2.00
Group 2 Model 81 — Trunnion on Head	Pivoted and Rigidly Guided	IV	1.00
Model 89 — Intermediate Trunnion	Pivoted and Rigidly Guided	V	1.50
Model 82 — Trunnion on Cap or Model 84 — Clevis on Cap	Pivoted and Rigidly Guided	VI	2.00

Miller AV Series Heavy-Duty Air Cylinders

Deceleration Force and
Air Requirements

Cushion ratings for **air cylinders only** are described in Table B-7 and Graph B-3. To determine whether a cylinder will adequately stop a load without damage to the cylinder, the weight of the load (including the weight of the piston and the piston rod from Table B-6) and the maximum speed of the piston rod must first be determined. Once these two factors are known, the Kinetic Energy Graph may be used. Enter the graph at its base for the value of weight determined, and project vertically to the required speed value. The point of intersection of these two lines will be the cushion rating number required for the application.

To determine the total load to be moved, the weight of the piston and rod must be included.

Total Weight = Weight of the piston and non-stroke rod length (Column 1) + weight of the rod per inch of stroke x the inches of stroke (Column 2) + the load to be moved.

Table B-6 — Weight

Bore Ø	Column 1 Basic Wgt. (Lbs.) for Piston & Non-Stroke Rod	Rod Ø	Column 2 Basic Wgt. (Lbs.) for 1" Stroke
1½	1.5	5/8	.087
2	3.0	1	.223
2½	5.4	1¾	.421
3¼	8.3	1¾	.682
4	14.2	2	.89
5	29	2½	1.39
6	41	3	2.0
8	89	3½	2.73
10	115	4	3.56
12	161	5	5.56
14	207	5½	6.73

Example: A 3-1/4" bore cylinder, having a 1" diameter rod and 25" stroke; load to be moved is 85 lbs. Total load to be moved is then 8.3 lbs. + .223 lbs./in. x 25 in. + 85 lbs. or a total of 99 lbs.

Graph B3 — Kinetic Energy — Air Cylinders

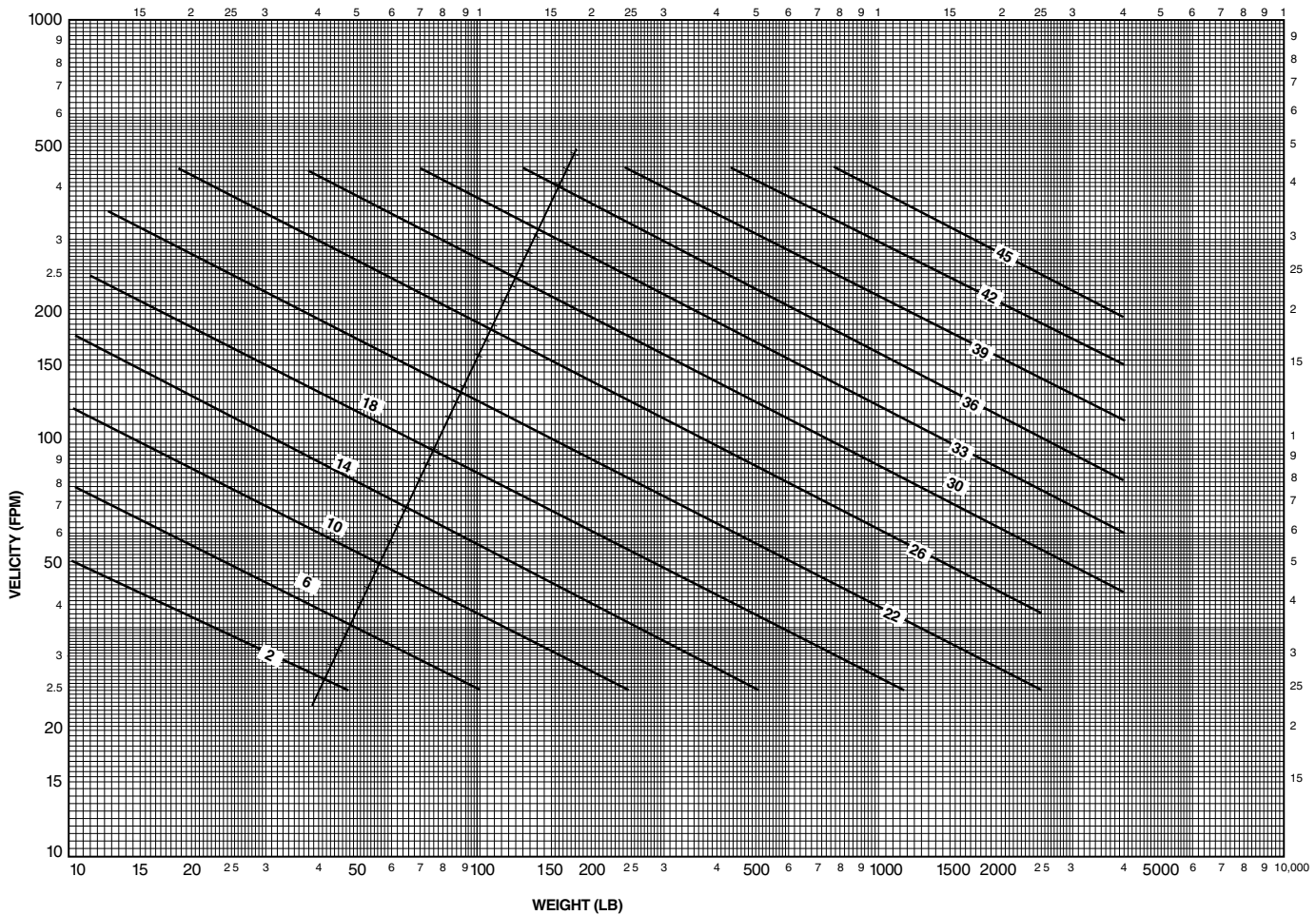

Miller AV Series Heavy-Duty Air Cylinders

Air Cylinder Cushion Ratings
Air Requirements

Now refer to Table B-7 and find the cushion ratings, using bore size and rod diameter of the cylinder selected. If a simple circuit is used, with no meter out or speed control, use the "no back pressure, Column A" values. If a meter out or speed control is to be used, use the back pressure column values. If the cushion rating found in Table B-7 (below) is **greater** than the number determined in Graph B-3, then

the cylinder will stop the load adequately. If the cushion rating in Table B-7 is **smaller** than the number found in Graph B-3, then a larger bore cylinder should be used. In those applications where back pressures exist in the exhaust lines, it is possible to exceed the cushion ratings shown in Table B-7. In these cases, consult the factory and advise the amount of back pressure.

Table B-7 — Air Cylinder Cushion Ratings

Bore Ø	Rod Ø	Rating with No Back Pressure	Rating with Back Pressure
1½	Cap End	12	17
	5/8	8	14
	1	3	8
2	Cap End	14	20
	5/8	12	18
	1	9	15
	1 3/8	6	11
2½	Cap End	17	23
	5/8	14	20
	1	14	19
	1 3/8	12	18
	1 3/4	8	13
3¼	Cap End	21	26
	5/8	18	24
	1 3/8	17	23
	1 3/4	16	22
	2	13	19
4	Cap End	23	28
	1	20	27
	1 3/8	20	26
	1 3/4	19	25
	2	17	23
	2½	17	22
5	Cap End	26	31
	1	23	28
	1 3/8	23	28
	1 3/4	22	28
	2	20	26
	2½	19	25
	3	18	24
6	3½	15	20
	Cap End	26	31
	1 3/8	26	31
	1 3/4	26	31
	2	24	29
	2½	24	29
	3	22	28
	3½	21	27
	4	20	26
7	Cap End	28	33
	1 3/8	28	33
	1 3/4	28	33
	2	26	31
	2½	25	30

Bore Ø	Rod Ø	Rating with No Back Pressure	Rating with Back Pressure
7	3	24	30
	3½	24	30
	4	23	29
	4½	22	28
	5	21	27
8	Cap End	29	35
	1 3/8	29	35
	1 3/4	29	34
	2	27	33
	2½	26	32
	3	26	32
	3½	26	32
	4	25	31
	5	23	29
	5½	22	28
10	Cap End	33	39
	1 3/4	32	38
	2	31	37
	2½	31	36
	3	30	36
	3½	30	36
	4	30	36
12	5	28	34
	5½	27	33
	Cap End	35	41
	2	33	39
	2½	33	38
	3	33	38
	3½	32	38
14	4	32	38
	5	31	36
	5½	31	36
	Cap End	38	43
	2½	37	42
	3	36	42
	3½	36	41
14	4	36	41
	5	35	40
	5½	34	40

Air Requirement per Inch of Cylinder Stroke

The amount of air required to operate a cylinder is determined from the volume of the cylinder and its cycle in strokes per minute. This may be determined by use of the following formulae which apply to a single-acting cylinder.

$$V = \frac{3.1416 L D^2}{4}$$

$$C = \frac{fV}{1728}$$

Where: V = Cylinder volume, cu. in.
L = Cylinder stroke length, in.
D = Internal diameter of cylinder in.
C = Air required, cfm
f = Number of strokes per minute

The air requirements for double-acting cylinder is almost double that of a single-acting cylinder, except for the volume of the piston rod.

Miller AV Series Heavy-Duty Air Cylinders

The air flow requirements of a cylinder in terms of cfm should not be confused with compressor ratings which are given in terms of free air. If compressor capacity is involved in the consideration of cylinder air requirements it will be necessary to convert cfm values to free air values. This relationship varies for different gauge pressures.

Thrust (lbs.) = Operating Pressure x Area of Cylinder Bore

Note: On the “out” stroke the air pressure is working on the entire piston area, but on the “in” stroke the air pressure works on the piston area less the rod area.

Graph B-4 and B-5 offer a simple means to select pneumatic components for dynamic cylinder applications. It is only necessary to know the force required, the desired speed and the pressure which can be maintained at the inlet to the F-R-L “Combo.” The graphs assume average

conditions relative to air line sizes, system layout, friction, etc. At higher speeds, consider appropriate cushioning of cylinders.

The general procedure to follow when using these graphs is:

1. Select the appropriate graph depending upon the pressure which can be maintained to the system — Graph B-4 for 100 psig and Graph B-5 for 80 psig.
2. Determine appropriate cylinder bore. Values underneath the diagonal cylinder bore lines indicate the maximum recommended dynamic thrust developed while the cylinder is in motion. The data in the table at the bottom of each graph indicates available static force for applications in which clamping force is a prime consideration in determining cylinder bore.

Graph B-4 — This graph is determined by having 100 psig available under flowing conditions.

THIS GRAPH IS DETERMINED BY HAVING
100 PSIG AVAILABLE UNDER FLOWING CONDITIONS.

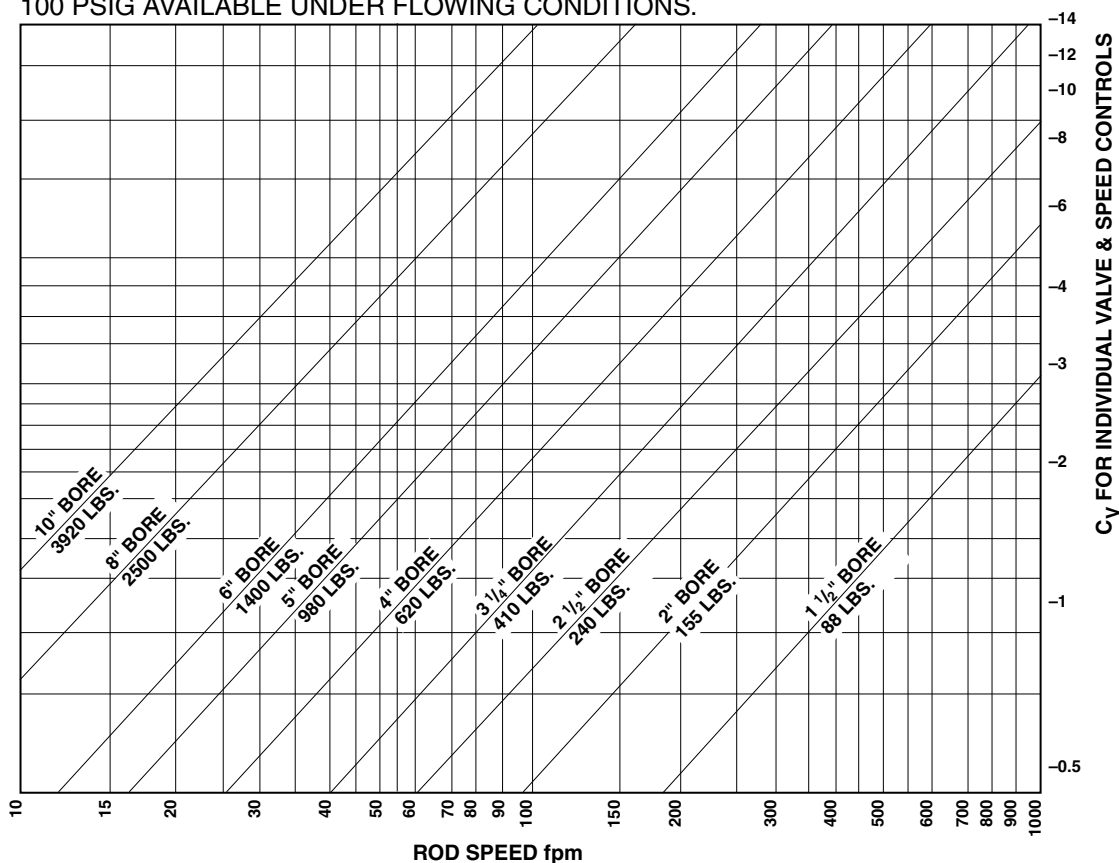

Table B-8 — Thrust Developed

Bore Size	1½	2	2½	3¼	4	5	6	8	10
Dynamic Thrust (lbs.)	88	155	240	410	620	980	1400	2500	3920
Static Thrust (lbs.)	177	314	491	830	1250	1960	2820	5020	7850

Miller AV Series Heavy-Duty Air Cylinders

3. Read upward on appropriate rod speed line to intersection with diagonal cylinder bore line. Read right from intersection point to determine the required Cv of the valve and the speed controls. Both the valve and speed controls must have this Cv.

The following examples illustrate use of the graphs:

Example 1: Assume it is necessary to raise a 900 lb. load 24 inches in two seconds. With 100 psig maintained at the inlet to the F-R-L, use Graph B-4. The 5-inch bore cylinder is capable of developing the required thrust while in motion. Since 24 inches in two seconds is equal to 60 fpm, read upward on the 60 fpm line to the intersection of the 5-inch bore diagonal line. Reading to the right indicates that the required valve and speed controls must each have a Cv of over 1.9.

Example 2: Assume similar conditions to Example 1, except that only 80 psig will be available under flowing conditions. Using Graph B-5, a 6-inch bore cylinder is indicated. Read upward on the 60 fpm line to the intersection point. Interpolation of the right-hand scale indicates a required valve and speed control Cv of over 2.8.

Example 3: Assume similar conditions to Example 1, except that the load is being moved in a horizontal plane with a coefficient of sliding friction of 0.2. Only a 180 lb. thrust is now required (900 lb. x 0.2). Consult Graph B-4. The 2½ inch bore cylinder will develop sufficient thrust, and at 60 fpm requires a valve and speed control Cv of about 0.5.

Graph B-5 — This graph is determined by having 80 psig available under flowing conditions.

THIS GRAPH IS DETERMINED BY HAVING 80 PSIG AVAILABLE UNDER FLOWING CONDITIONS.

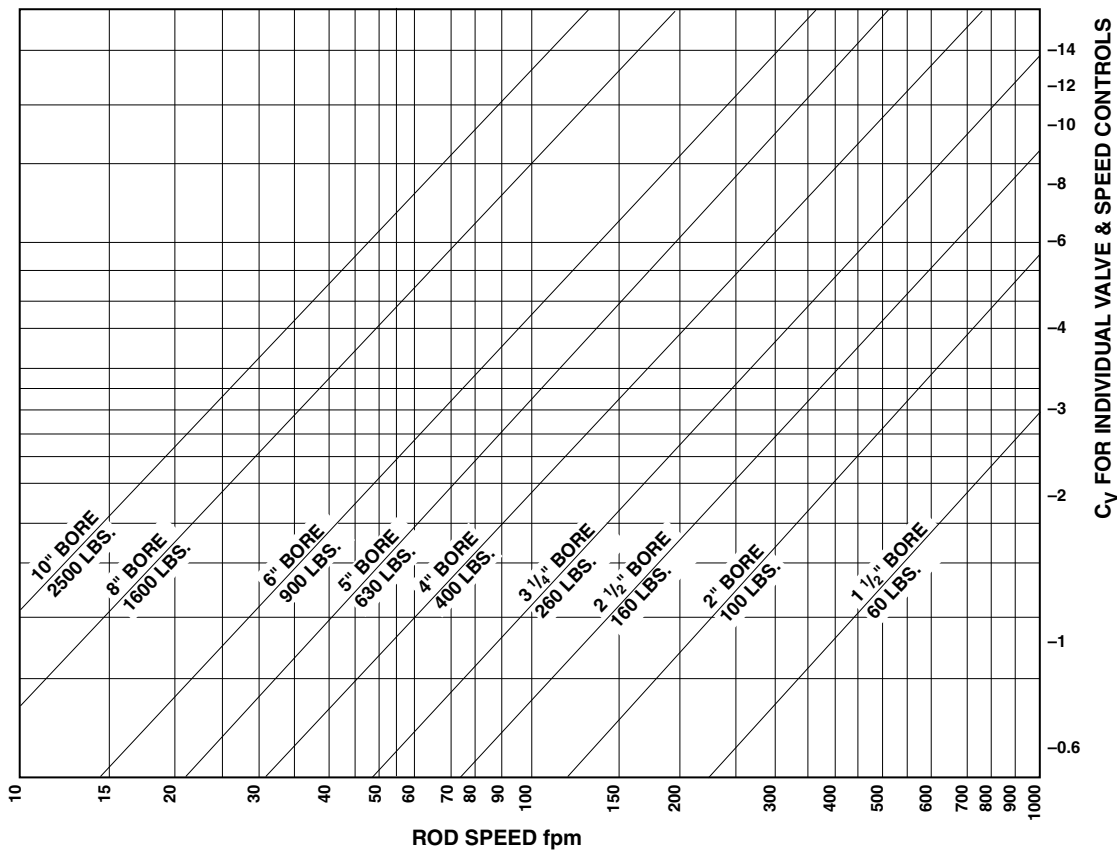

Table B-9 — Thrust Developed

Bore Size	1½	2	2½	3¼	4	5	6	8	10
Dynamic Thrust (lbs.)	60	100	160	260	400	630	900	1600	2500
Static Thrust (lbs.)	141	251	393	663	1000	1570	2260	4010	6280

Miller AV Series Heavy-Duty Air Cylinders

Notes

NOTES

Miller AV Series Heavy-Duty Air Cylinders

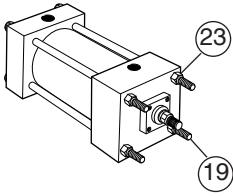
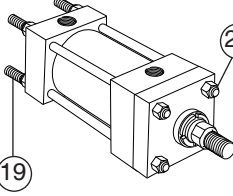
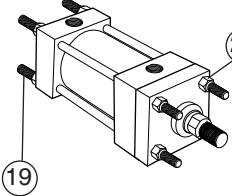
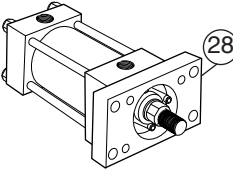
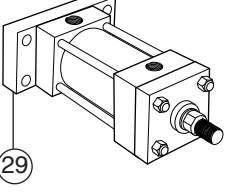
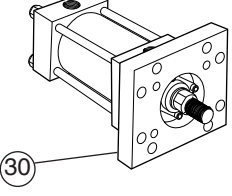
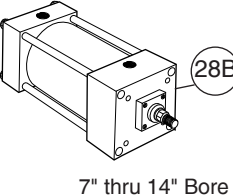
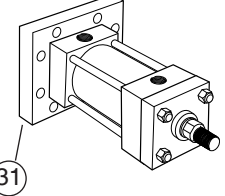
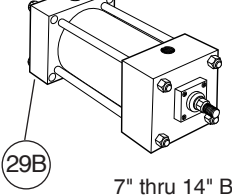
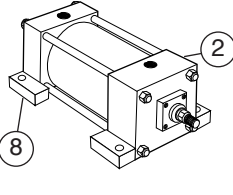
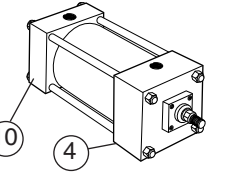
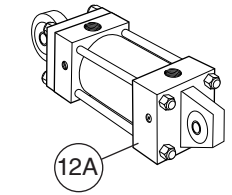
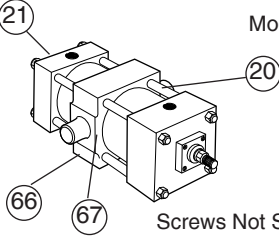
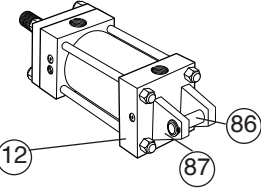
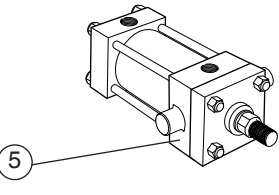
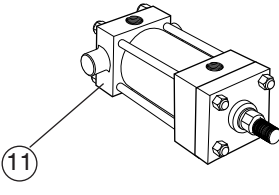
			Replacement Mountings & Hardware	
			Symbol	Description
Model 53 	Model 52 	Model 51 		
Model 61 	Model 62 	Model 65 		
Model 63  7" thru 14" Bore	Model 66 	Model 64  7" thru 14" Bore		
Model 72 	Model 74 	Model 94 		
Model 89  Screws Not Shown	Model 84 			
Model 81 	Model 82 			
			How to Order Give cylinder model number, bore, stroke, serial number and symbol number shown above to insure proper replacement.	

Miller AV Series Heavy-Duty Air Cylinders

Parts Identification

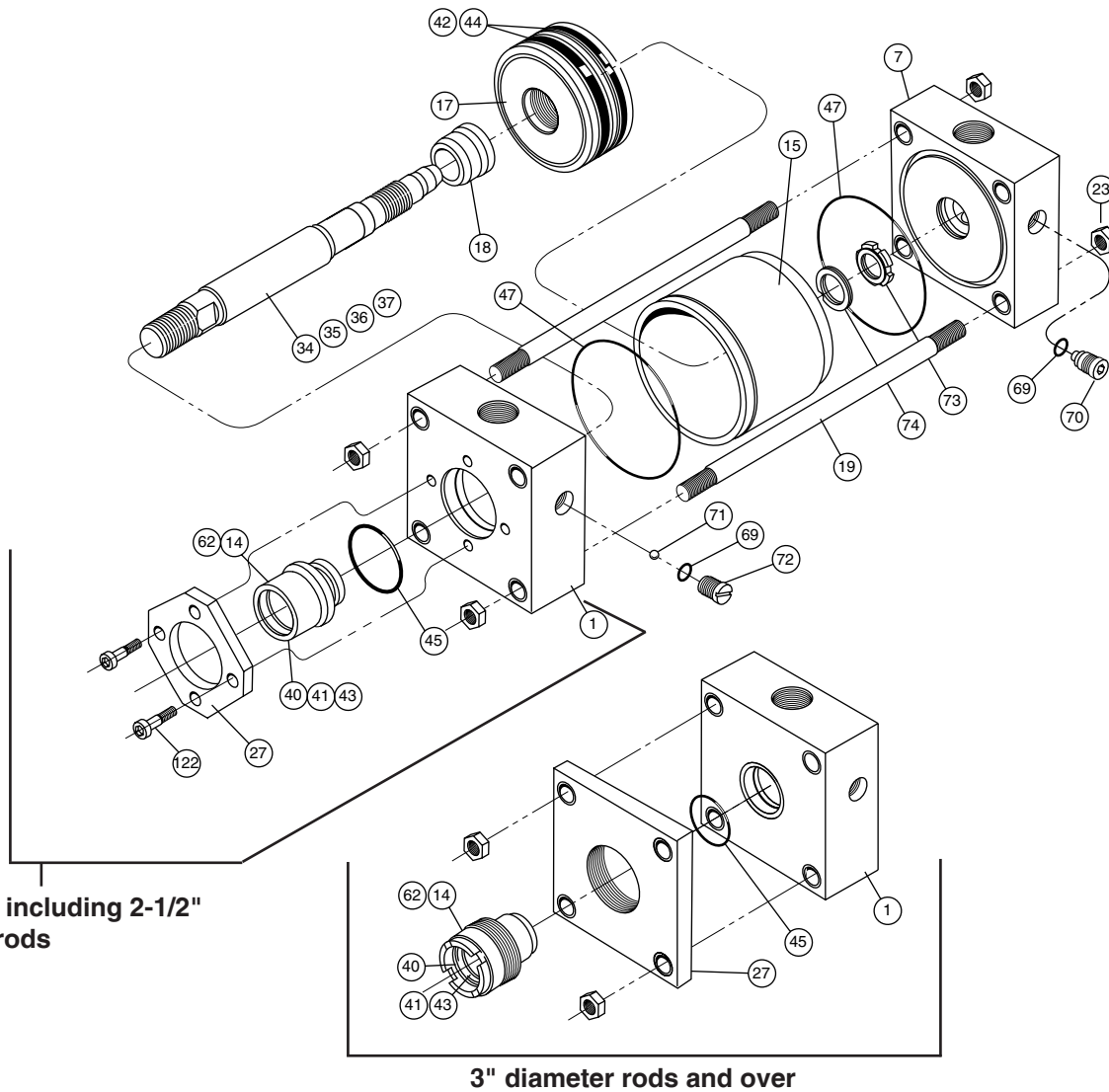

Double End Rod and Piston Assembly

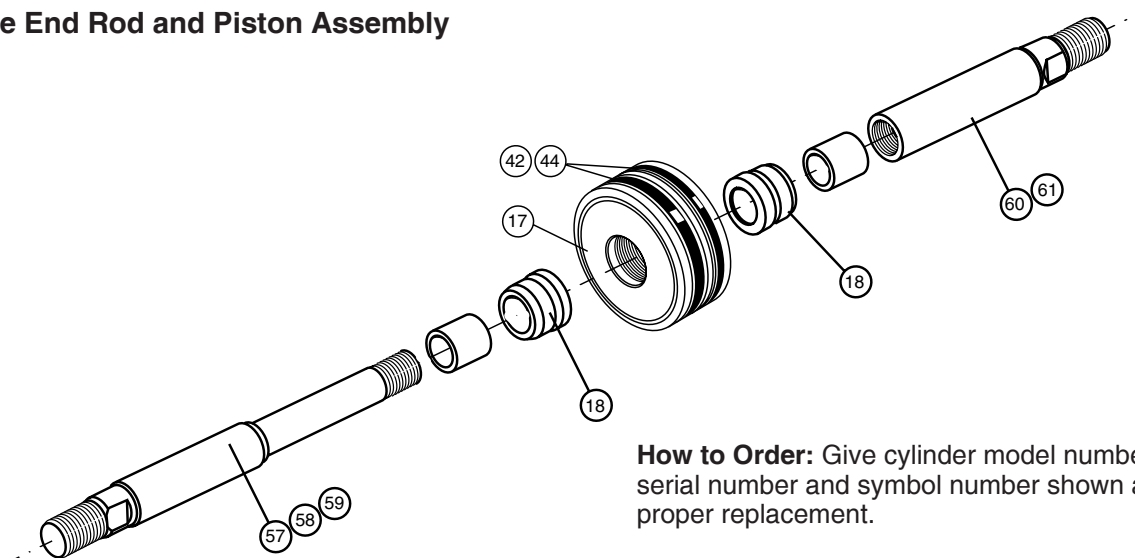

Miller AV Series Heavy-Duty Air Cylinders

Parts Identification
Cushion Kits

Parts		Assemblies (Includes Symbol Numbers Shown)		
Symbol	Description	Symbol	Description	Lipseal Type Piston
1	Head, ported, non-cushioned	C1SA	Head, ported, cushioned	1, 69, 70, 71 & 72
7	Cap, ported, non-cushioned	C7SA	Cap, ported, cushioned	7, 69, 70, 73 & 74
14	Bushing	62	Bushing kit	14, 40, 41, 43 & 45
15	Tube	-	-	-
17	Piston, lipseal type	-	-	-
18	Cushion plunger, cushioned cylinder only	-	-	-
19	Tie rod	-	-	-
23	Tie rod nut	-	-	-
27	Retainer	-	-	-
34	Piston rod, single rod type, non-cushioned	34SA	Piston & rod assembly, single rod type — non-cushioned	17, 34, 42 & 44
35	Piston rod, single rod type, cushioned head end	35SA	Piston & rod assembly, single rod type — cush. head end	17, 18, 35, 42 & 44
36	Piston rod, single rod type, cushioned cap end	36SA	Piston & rod assembly, single rod type — cush. cap end	17, 36, 42 & 44
37	Piston rod, single rod type, cushioned both ends	37SA	Piston & rod assembly, single rod type — cush. both ends	17, 18, 37, 42 & 44
40	Rod wiper	-	-	-
41	Rod seal	-	-	-
42	Piston seal	-	-	-
43	Back-up washer, bushing	-	Seal Kits	-
44	Back-up washer, piston	-		-
45	O-ring, bushing to head seal	-		-
47	O-ring, cylinder tube end seal	-		-
57	Piston rod, double rod type, non-cushioned	57SA		Piston & Rod assembly, double rod type — non-cush.
58	Piston rod, double rod type, cushioned one end	58SA	Piston & rod assembly, double rod type — cush. one end	17, 18, 42, 44, 58 & 60
59	Piston rod, double rod type, cushioned both ends	59SA	Piston & rod assembly, double rod type — cush. both ends	17, 18, 42, 44, 58 & 61
60	Piston rod extension, double rod type — non-cushioned	-	-	-
61	Piston Rod extension, double rod type — cushioned	-	-	-
69	O-ring, cushion adjustment & check valve screw	-	-	-
70	Needle valve, cushion adjustment	-	Cushion Kits See table below.	-
71	Ball, check valve	-		-
72	Plug screw, check valve	-		-
73	Cushion bushing, cap end floating check valve	-		-
74	Retaining ring, floating cushion bushing	-	-	-
122	Socket cap screws	-	-	-

Standard Cushion Hardware Kits

Bore Size	Rod Ø	For Head Assemblies	For Cap Assemblies
		Order Kits by Number Below: (Kits Include Symbols 69, 70, 71 & 72 for One Head)	Order Kits by Number Below: (Kits Include Symbols 69, 70, 73 & 74 for One Cap)
1	None	None	None
1½	5/8	AV-CUKH1-1	AV-CUKC1-4
	1	AV-CUKH1-1M	
2	5/8, 1	AV-CUKH1-1	AV-CUKC1-4
	1³/8	AV-CUKH1-1M	
2½	5/8, 1, A	AV-CUKH1-1	AV-CUKC1-4
	1¾	AV-CUKH1-1M	
3¼	All	AV-CUKH1-2	AV-CUKC1-5
4	All	AV-CUKH1-2	AV-CUKC1-5
5	All	AV-CUKH1-2A	AV-CUKC1-5A
6	1³/8-3½	AV-CUKH1-3	AV-CUKC1-6
	4	AV-CUKH1-2	AV-CUKC1-6A
7	All	AV-CUKH1-3	AV-CUKC1-6
8	All	AV-CUKH1-3	AV-CUKC1-6
10	All	AV-CUKH1-3	AV-CUKC1-7
12	All	AV-CUKH1-3	AV-CUKC1-8
14	All	AV-CUKH1-3	AV-CUKC1-9

Fluorocarbon Cushion Hardware Kits

Bore Size	Rod Ø	For Head Assemblies	For Cap Assemblies
		Order Kits by Number Below: (Kits Include Symbols 69, 70, 71 & 72)	Order Kits by Number Below: (Kits Include Symbols 69, 70, 73 & 74)
1	None	None	None
1½	5/8	AV-CUKH5-18	AV-CUKC5-22
	1	AV-CUKH5-18M	
2	5/8, 1	AV-CUKH5-18	AV-CUKC5-22
	1³/8	AV-CUKH5-18M	
2½	5/8, 1, 1³/8	AV-CUKH5-18	AV-CUKC5-22
	1¾	AV-CUKH5-18M	
3¼	All	AV-CUKH5-19	AV-CUKC5-23
4	All	AV-CUKH5-19	AV-CUKC5-23
5	All	AV-CUKH5-19A	AV-CUKC5-23A
6	1³/8-3½	AV-CUKH5-21	AV-CUKC5-24
	4	AV-CUKH5-19	AV-CUKC5-24A
7	All	AV-CUKH5-21	AV-CUKC5-24
8	All	AV-CUKH5-21	AV-CUKC5-24
10	All	AV-CUKH5-21	AV-CUKC5-25
12	All	AV-CUKH5-21	AV-CUKC5-26
14	All	AV-CUKH5-21	AV-CUKC5-27

Miller AV Series Heavy-Duty Air Cylinders

Parts Identification
Seal Kits
Standard Seals

Symbol	Description
14	Bushing
40	Rod wiper
41	Rod seal
42	Piston lipseal
43	Bushing back-up washer
44	Piston back-up washer
45	Bushing to head o-ring
47	End seal o-ring
62	Bushing kit

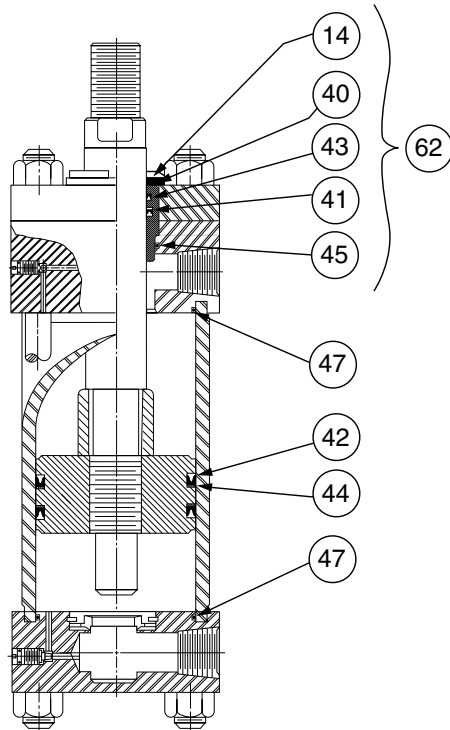

Seal Kits for Class 1 Service

Material: Buna-N (Nitrile)

For operating temperature and fluid compatibility, see "Operating Fluids and Temperature Range" page.

Bushing and spanner wrenches are available to ease (rod) seal or bushing removal without disassembly of the cylinder. **(For rod diameters over 2 1/2".)**

For detailed seal replacement instructions see service bulletin M0995-M1, M2 and M3.

Rod Ø	Bushing Kits (Symbol 62) Contains Symbols 14, 40, 41, 43 & 45	Rod Seal Kits Contains Symbols 40, 41, 43 & 45	Bushing Wrench	Spanner Wrench
1/2	AV-KR100-50	AV-KR300-50	Not Required	Not Required
5/8	AV-KR100-63	AV-KR300-63		
1	AV-KR100-100	AV-KR300-100		
1 3/8	AV-KR100-138	AV-KR300-138		
1 3/4	AV-KR100-175	AV-KR300-175		
2	AV-KR100-200	AV-KR300-200		
2 1/2	AV-KR100-250	AV-KR300-250	069596 0000	011677 0000
3	AV-KR100-300	AV-KR300-300	069597 0000	011677 0000
3 1/2	AV-KR100-350	AV-KR300-350	069598 0000	011678 0000
4	AV-KR100-400	AV-KR300-400	083877 0000	011678 0000
4 1/2	AV-KR100-450	AV-KR300-450	069599 0000	011678 0000
5	AV-KR100-500	AV-KR300-500	069600 0000	011678 0000
5 1/2	AV-KR100-550	AV-KR300-550		

Bore Size	Piston Seal Kits Contains 2 Each Symbols: 42, 44 & 47
1	AV-KB100-100
1 1/2	AV-KB100-150
2	AV-KB100-200
2 1/2	AV-KB100-250
3 1/4	AV-KB100-325
4	AV-KB100-400
5	AV-KB100-500
6	AV-KB100-600
7	AV-KB100-700
8	AV-KB100-800
10	AV-KB100-1000
12	AV-KB100-1200
14	AV-KB100-1400

Bore Size	Cylinder Tube Seal Kits Contains 2 Each Symbol 47	Tie Rod Torque Specifications (Ft. Lbs.)
		AV Series Steel Cylinder Tube
1	AV-ES100-100	2
1 1/2	AV-ES100-150	5
2	AV-ES100-200	11
2 1/2	AV-ES100-250	11
3 1/4	AV-ES100-325	25
4	AV-ES100-400	25
5	AV-ES100-500	60
6	AV-ES100-600	60
7	AV-ES100-700	90
8	AV-ES100-800	110
10	AV-ES100-1000	150
12	AV-ES100-1200	172
14	AV-ES100-1400	275

How to Order

Individual seals contained in the kits are available separately; however, we recommend purchasing complete kits because of convenience and lower replacement cost. When ordering seal kits, give part number listed above. To be sure of exact replacement, give serial number of cylinder when ordering replacement kits or seals.

Miller AV Series Heavy-Duty Air Cylinders

Parts Identification
Seal Kits
Group 5 Service

Symbol	Description
14	Bushing
40	Rod wiper
41	Rod seal
42	Piston lipseal
43	Bushing back-up washer
44	Piston back-up washer
45	Bushing to head o-ring
47	End seal o-ring
62	Bushing kit

Seal Kits for Class 5 Service

Material: Fluorocarbon

For operating temperature and fluid compatibility, see "Operating Fluids and Temperature Range" page.

Bushing and spanner wrenches are available to ease (rod) seal or bushing removal without disassembly of the cylinder. **(For rod diameters over 2 1/2".)**

For detailed seal replacement instructions see service bulletin M0995-M1, M3 and M5.

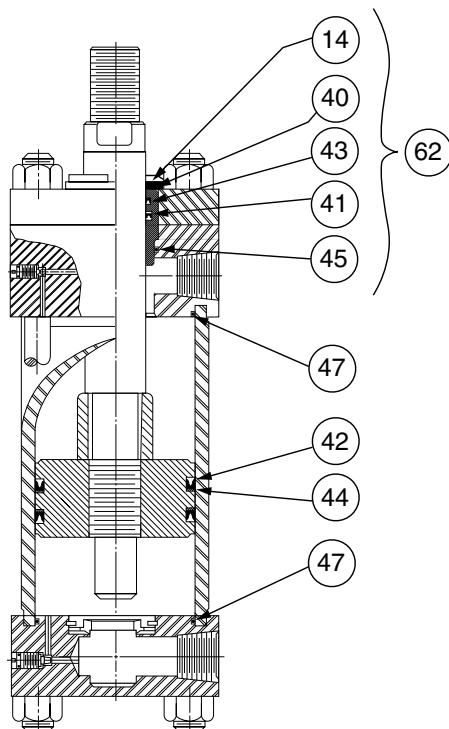

Rod Ø	Bushing (Symbol 62) Kits Contains Symbols 14, 40, 41, 43 & 45	Rod Seal Kits Contains Symbols 40, 41, 43 & 45	Bushing Wrench	Spanner Wrench
1/2	AV-KR200-50	AV-KR400-50	Not Required	Not Required
5/8	AV-KR200-63	AV-KR400-63		
1	AV-KR200-100	AV-KR400-100		
1 3/8	AV-KR200-138	AV-KR400-138		
1 3/4	AV-KR200-175	AV-KR400-175		
2	AV-KR200-200	AV-KR400-200		
2 1/2	AV-KR200-250	AV-KR400-250	069596 0000	011677 0000
3	AV-KR200-300	AV-KR400-300	069597 0000	011677 0000
3 1/2	AV-KR200-350	AV-KR400-350	069598 0000	011678 0000
4	AV-KR200-400	AV-KR400-400	083877 0000	011678 0000
4 1/2	AV-KR200-450	AV-KR400-450	069599 0000	011678 0000
5	AV-KR200-500	AV-KR400-500	069600 0000	011678 0000
5 1/2	AV-KR200-550	AV-KR400-550		

Bore Size	Piston Seal Kits Contains 2 Each Symbols: 42, 44 & 47
1	AV-KB200-100
1 1/2	AV-KB200-150
2	AV-KB200-200
2 1/2	AV-KB200-250
3 1/4	AV-KB200-325
4	AV-KB200-400
5	AV-KB200-500
6	AV-KB200-600
7	AV-KB200-700
8	AV-KB200-800
10	AV-KB200-1000
12	AV-KB200-1200
14	AV-KB200-1400

Bore Size	Tube Seal Kits Contains 2 Each Symbol 47	Tie Rod Torque Specifications (Ft. Lbs.)
		AV Series Steel Cylinder Tube
1	AV-ES200-100	2
1 1/2	AV-ES200-150	5
2	AV-ES200-200	11
2 1/2	AV-ES200-250	11
3 1/4	AV-ES200-325	25
4	AV-ES200-400	25
5	AV-ES200-500	60
6	AV-ES200-600	60
7	AV-ES200-700	90
8	AV-ES200-800	110
10	AV-ES200-1000	150
12	AV-ES200-1200	172
14	AV-ES200-1400	275

How to Order

Individual seals contained in the kits are available separately; however, we recommend purchasing complete kits because of convenience and lower replacement cost. When ordering seal kits, give part number listed above. To be sure of exact replacement, give serial number of cylinder when ordering replacement kits or seals.

Miller AVN Series Heavy-Duty Air Cylinders

AVN Series
Seal Kits
Parts Identification

Standard Seals — Class 1 Service Kits are standard. In addition to standard seals, each kit includes the special composite components ready for installation. These seals are suitable for use when air is the operating medium.

The recommended operating temperature range for Class 1 seals is -10° F to +165°F.

Seal Kits

Bushing Kit

Rod Size	Contains Symbols 14, 40, 41 & 45
5/8	AVN-KR100-63
1	AVN-KR100-100
1 3/8	AVN-KR100-138
1 3/4	AVN-KR100-175
2	AVN-KR100-200

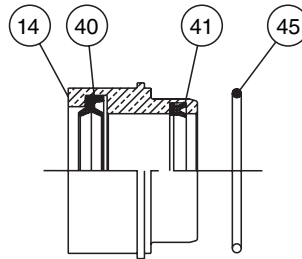

Rod Seal Kit

Rod Size	Contains Symbols 40, 41 & 45
5/8	AVN-KR300-63
1	AVN-KR300-100
1 3/8	AVN-KR300-138
1 3/4	AVN-KR300-175
2	AVN-KR300-200

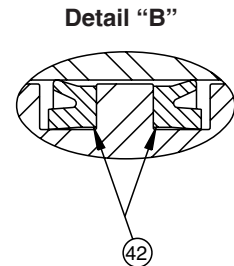
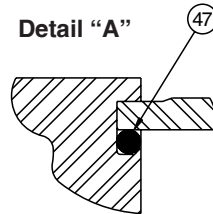
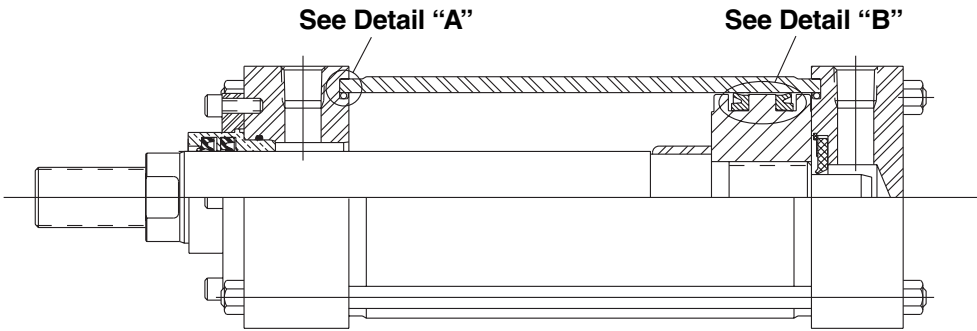

Bore Size	Piston Seal Kit Consisting of 2 Ea. Symbol 42 & 47	Cylinder Tube Seal Kit Consisting of 2 Ea. Symbol 47
1 1/2	AVN-KB100-150	AVN-ES100-150
2	AVN-KB100-200	AVN-ES100-200
2 1/2	AVN-KB100-250	AVN-ES100-250
3 1/4	AVN-KB100-325	AVN-ES100-325
4	AVN-KB100-400	AVN-ES100-400
5	AVN-KB100-500	AVN-ES100-500
6	AVN-KB100-600	AVN-ES100-600
7	AVN-KB100-700	AVN-ES100-700
8	AVN-KB100-800	AVN-ES100-800
10	AVN-KB100-1000	AVN-ES100-1000

Miller AV Series Heavy-Duty Air Cylinders

Notes

NOTES

Miller AV Series Heavy-Duty Air Cylinders

Model Numbers

How to Order AV Series Cylinders

Data Required On All Cylinder Orders

When ordering AV Series cylinders, be sure to specify each of the following requirements:

(NOTE: – Duplicate cylinders can be ordered by giving the SERIAL NUMBER from the original cylinder. Factory records supply a quick, positive identification.)

a) Series Designation (“AV”)

b) Mounting Model

Specify your choice of mounting – as shown and dimensioned in this catalog.

c) Bushing Style (“B” or “R”)

d) Piston Rod End Thread Style

Call out thread style number. Thread style 2 will be furnished if not otherwise supplied. For special rod ends specify style “X” as indicated below.

e) Cushions (if required)

Specify “Cushion-head end,” “Cushion-cap end” or “Cushion-both ends” as required. If cylinder is to have a double rod and only one cushion is required, be sure to specify clearly which end of the cylinder is to be cushioned.

f) Bore Size

g) Length of Stroke

h) Piston Rod Diameter

Call out rod diameter. In AV Series cylinders, standard rod diameters will be furnished if not otherwise specified, unless length of stroke makes the application questionable.

i) Ports

NPTF is standard.

j) Port Locations

k) Modifications

Any modifications that are not identified in the cylinder number shown on the following page should be added to the specifications. These can include special fluids, special seals, air bleeds, double rod cylinder with different rod end styles and diameters. For further information consult factory.

Style X Rod End

A style X rod end indicates a special rod end configuration. All special rod ends must be described by at least **all three**: KK; A; or W/WF specified with the rod fully retracted. A sketch or drawing should be submitted for rod ends requiring special machining such as snap ring grooves,

keyways, tapers, multiple diameters, etc. It is good design practice to have this machining done on a diameter at least 0.065 inches smaller than the piston rod diameter. This allows the piston rod to have a chamfer preventing rod seal damage during assembly or maintenance.

Service Policy

When cylinders are returned to the factory for repairs, it is standard policy for Miller Fluid Power to make such part replacements as will put the cylinder in as good as new condition. Should the condition of the returned cylinder be such that expenses for repair exceed the cost of a new one, you will be notified.

Certified Dimensions

Miller Fluid Power guarantees that all cylinders ordered from this catalog will be built to dimensions shown. All dimensions are certified to be correct, and thus it is not necessary to request certified drawings.

Miller AV Series Heavy-Duty Air Cylinders

How to Order – Example: AV72B2N-04.00-8.000-0138 N11-0

Series	Mounting Style	Bushing	Rod End Style	Cushions	Bore Dia.	Stroke	Rod Dia.	Port Type	Port Location		Modified
AV DAV (D = Dbl. Rod End AVN (N = Non-Lube) DAVN		B = Bolted Bushing R = Retainer Held Bushing	2 (Standard) 4 5 X (Special)	R = Rod End Cushioned C = Cap End Cushioned B = Both Ends Cushioned N = Non-Cushioned				N = NPTF	Head End 1 (Std.) 2 3 4	Cap End 1 2 3 4	0 = Standard 9* = Modified

9* The number 9 refers to special options or modifications that deviate from the standard product offering. Non-standard modifications and options not identified in the cylinder model number should be added in the notes when placing an order.

Modifications which can be placed under the designator “9” are as follows:

- Fluorocarbon Seals – for applications which experience operating temperatures up to and including 250°F
- Multiple Ports
- Special Port Threads
- Cushion Location
- Special Mounts

Note: The standard #1 port location is at the top of the cylinder, and the standard cushion adjustment screw is in position #2 when facing the rod end of the cylinder. If multiple ports are required, the last number of the part number should be “9”, indicating modified and the desired port location specified in the notes.

Cushions not available on 1" bore.

Rod Ø	RD Across Corners
5/8"	1 ⁶³ / ₆₄
1"	2 ³¹ / ₆₄
1 ³ / ₈ "	2 ⁶³ / ₆₄
1 ³ / ₄ "	3 ⁴¹ / ₆₄
2"	3 ³ / ₄
2 ¹ / ₂ "	4 ²¹ / ₆₄

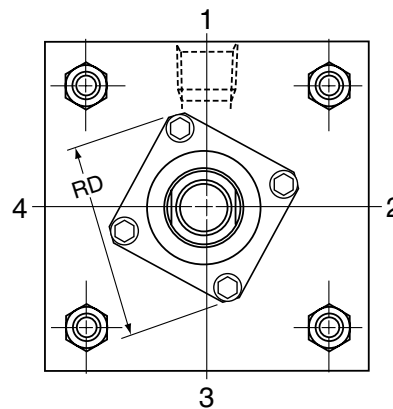

Miller AV Series Heavy-Duty Air Cylinders

Safety Guide for Selecting and Using Hydraulic, Pneumatic Cylinders and Their Accessories

WARNING: ⚠️ **FAILURE OF THE CYLINDER, ITS PARTS, ITS MOUNTING, ITS CONNECTIONS TO OTHER OBJECTS, OR ITS CONTROLS CAN RESULT IN:**

- Unanticipated or uncontrolled movement of the cylinder or objects connected to it.
- Falling of the cylinder or objects held up by it.
- Fluid escaping from the cylinder, potentially at high velocity.

THESE EVENTS COULD CAUSE DEATH OR PERSONAL INJURY BY, FOR EXAMPLE, PERSONS FALLING FROM HIGH LOCATIONS, BEING CRUSHED OR STRUCK BY HEAVY OR FAST MOVING OBJECTS, BEING PUSHED INTO DANGEROUS EQUIPMENT OR SITUATIONS, OR SLIPPING ON ESCAPED FLUID.

Before selecting or using Parker Hannifin Corporation (the Company) cylinders or related accessories, it is important that you read, understand and follow the following safety information. Training is advised before selecting and using the Company's products.

1.0 General Instructions

1.1 Scope – This safety guide provides instructions for selecting and using (including assembling, installing, and maintaining) cylinder products. This safety guide is a supplement to and is to be used with the specific Company publications for the specific cylinder products that are being considered for use.

1.2 Fail Safe – Cylinder products can and do fail without warning for many reasons. All systems and equipment should be designed in a fail-safe mode so that if the failure of a cylinder product occurs people and property won't be endangered.

1.3 Distribution – Provide a free copy of this safety guide to each person responsible for selecting or using cylinder products. Do not select or use the Company's cylinders without thoroughly reading and understanding this safety guide as well as the specific Company publications for the products considered or selected.

1.4 User Responsibility – Due to very wide variety of cylinder applications and cylinder operating conditions, the Company does not warrant that any particular cylinder is suitable for any specific application. This safety guide does not analyze all technical parameters that must be considered in selecting a product. The hydraulic and pneumatic cylinders outlined in this catalog are designed to the Company's design guidelines and do not necessarily meet the design guideline of other agencies such as American Bureau of Shipping, ASME Pressure Vessel Code etc. The user, through its own analysis and testing, is solely responsible for:

- Making the final selection of the cylinders and related accessories.
- Determining if the cylinders are required to meet specific design requirements as required by the Agency(s) or industry standards covering the design of the user's equipment.
- Assuring that the user's requirements are met, OSHA requirements are met, and safety guidelines from the applicable agencies such as but not limited to ANSI are followed and that the use presents no health or safety hazards.
- Providing all appropriate health and safety warnings on the equipment on which the cylinders are used.

1.5 Additional Questions – Call the appropriate Company technical service department if you have any questions or require any additional information. See the Company publication for the product being considered or used, or call 1-847-298-2400, or go to www.parker.com, for telephone numbers of the appropriate technical service department.

2.0 Cylinder and Accessories Selection

2.1 Seals – Part of the process of selecting a cylinder is the selection of seal compounds. Before making this selection, consult the "seal information page(s)" of the publication for the series of cylinders of interest.

The application of cylinders may allow fluids such as cutting fluids, wash down fluids etc. to come in contact with the external area of the cylinder. These fluids may attack the piston rod wiper and or the primary seal and must be taken into account when selecting and specifying seal compounds.

Dynamic seals will wear. The rate of wear will depend on many operating factors. Wear can be rapid if a cylinder is mis-aligned or if the cylinder has been improperly serviced. The user must take seal wear into consideration in the application of cylinders.

2.2 Piston Rods – Possible consequences of piston rod failure or separation of the piston rod from the piston include, but are not limited to are:

- Piston rod and or attached load thrown off at high speed.
- High velocity fluid discharge.
- Piston rod extending when pressure is applied in the piston retract mode.

Piston rods or machine members attached to the piston rod may move suddenly and without warning as a consequence of other conditions occurring to the machine such as, but not limited to:

- Unexpected detachment of the machine member from the piston rod.

- Failure of the pressurized fluid delivery system (hoses, fittings, valves, pumps, compressors) which maintain cylinder position.
- Catastrophic cylinder seal failure leading to sudden loss of pressurized fluid.
- Failure of the machine control system.

Follow the recommendations of the "Piston Rod Selection Chart and Data" in the publication for the series of cylinders of interest. The suggested piston rod diameter in these charts must be followed in order to avoid piston rod buckling.

Piston rods are not normally designed to absorb bending moments or loads which are perpendicular to the axis of piston rod motion. These additional loads can cause the piston rod to fail. If these types of additional loads are expected to be imposed on the piston rod, their magnitude should be made known to our engineering department.

The cylinder user should always make sure that the piston rod is securely attached to the machine member.

On occasion cylinders are ordered with double rods (a piston rod extended from both ends of the cylinder). In some cases a stop is threaded on to one of the piston rods and used as an external stroke adjuster. On occasions spacers are attached to the machine member connected to the piston rod and also used as a stroke adjuster. In both cases the stops will create a pinch point and the user should consider appropriate use of guards. If these external stops are not perpendicular to the mating contact surface, or if debris is trapped between the contact surfaces, a bending moment will be placed on the piston rod, which can lead to piston rod failure. An external stop will also negate the effect of cushioning and will subject the piston rod to impact loading. Those two (2) conditions can cause piston rod failure. Internal stroke adjusters are available with and without cushions. The use of external stroke adjusters should be reviewed with our engineering department.

The piston rod to piston and the stud to piston rod threaded connections are secured with an anaerobic adhesive. The strength of the adhesive decreases with increasing temperature. Cylinders which can be exposed to temperatures above +250°F (+121°C) are to be ordered with a non studded piston rod and a pinned piston to rod joint.

2.3 Cushions – Cushions should be considered for cylinder applications when the piston velocity is expected to be over 4 inches/second.

Cylinder cushions are normally designed to absorb the energy of a linear applied load. A rotating mass has considerably more energy than the same mass moving in a linear mode. Cushioning for a rotating mass application should be reviewed by our engineering department.

2.4 Cylinder Mountings – Some cylinder mounting configurations may have certain limitations such as but not limited to minimum stroke for side or foot mounting cylinders or pressure de-ratings for certain mounts. Carefully review the catalog for these types of restrictions.

Always mount cylinders using the largest possible high tensile alloy steel socket head cap screws that can fit in the cylinder mounting holes and torque them to the manufacturer's recommendations for their size.

2.5 Port Fittings – Hydraulic cylinders applied with meter out or deceleration circuits are subject to intensified pressure at piston rod end.

The rod end pressure is approximately equal to:

$$\frac{\text{operating pressure} \times \text{effective cap end area}}{\text{effective rod end piston area}}$$

Contact your connector supplier for the pressure rating of individual connectors.

3.0 Cylinder and Accessories Installation and Mounting

3.1 Installation

3.1.1 – Cleanliness is an important consideration, and cylinders are shipped with the ports plugged to protect them from contaminants entering the ports. These plugs should not be removed until the piping is to be installed. Before making the connection to the cylinder ports, piping should be thoroughly cleaned to remove all chips or burrs which might have resulted from threading or flaring operations.

Miller AV Series Heavy-Duty Air Cylinders

3.1.2 – Cylinders operating in an environment where air drying materials are present such as fast-drying chemicals, paint, or weld splatter, or other hazardous conditions such as excessive heat, should have shields installed to prevent damage to the piston rod and piston rod seals.

3.1.3 – Proper alignment of the cylinder piston rod and its mating component on the machine should be checked in both the extended and retracted positions. Improper alignment will result in excessive rod gland and/or cylinder bore wear. On fixed mounting cylinders attaching the piston rod while the rod is retracted will help in achieving proper alignment.

3.1.4 – Sometimes it may be necessary to rotate the piston rod in order to thread the piston rod into the machine member. This operation must always be done with zero pressure being applied to either side of the piston. Failure to follow this procedure may result in loosening the piston to rod-threaded connection. In some rare cases the turning of the piston rod may rotate a threaded piston rod gland and loosen it from the cylinder head. Confirm that this condition is not occurring. If it does, re-tighten the piston rod gland firmly against the cylinder head.

For double rod cylinders it is also important that when attaching or detaching the piston rod from the machine member that the torque be applied to the piston rod end of the cylinder that is directly attaching to the machine member with the opposite end unrestrained. If the design of the machine is such that only the rod end of the cylinder opposite to where the rod attaches to the machine member can be rotated, consult the factory for further instructions.

3.2 Mounting Recommendations

3.2.1 – Always mount cylinders using the largest possible high tensile alloy steel socket head screws that can fit in the cylinder mounting holes and torque them to the manufacturer's recommendations for their size.

3.2.2 – Side-Mounted Cylinders – In addition to the mounting bolts, cylinders of this type should be equipped with thrust keys or dowel pins located so as to resist the major load.

3.2.3 – Tie Rod Mounting – Cylinders with tie rod mountings are recommended for applications where mounting space is limited. The standard tie rod extension is shown as BB in dimension tables. Longer or shorter extensions can be supplied. Nuts used for this mounting style should be torqued to the same value as the tie rods for that bore size.

3.2.4 – Flange Mount Cylinders – The controlled diameter of the rod gland extension on head end flange mount cylinders can be used as a pilot to locate the cylinders in relation to the machine. After alignment has been obtained, the flanges may be drilled for pins or dowels to prevent shifting.

3.2.5 – Trunnion Mountings – Cylinders require lubricated bearing blocks with minimum bearing clearances. Bearing blocks should be carefully aligned and rigidly mounted so the trunnions will not be subjected to bending moments. The rod end should also be pivoted with the pivot pin in line and parallel to axis of the trunnion pins.

3.2.6 – Clevis Mountings – Cylinders should be pivoted at both ends with centerline of pins parallel to each other. After cylinder is mounted, be sure to check to assure that the cylinder is free to swing through its working arc without interference from other machine parts.

4.0 Cylinder and Accessories Maintenance, Troubleshooting and Replacement

4.1 Storage – At times cylinders are delivered before a customer is ready to install them and must be stored for a period of time. When storage is required the following procedures are recommended.

4.1.1 – Store the cylinders in an indoor area which has a dry, clean and noncorrosive atmosphere. Take care to protect the cylinder from both internal corrosion and external damage.

4.1.2 – Whenever possible cylinders should be stored in a vertical position (piston rod up). This will minimize corrosion due to possible condensation which could occur inside the cylinder. This will also minimize seal damage.

4.1.3 – Port protector plugs should be left in the cylinder until the time of installation.

4.1.4 – If a cylinder is stored full of hydraulic fluid, expansion of the fluid due to temperature changes must be considered. Installing a check valve with free flow out of the cylinder is one method.

4.1.5 – When cylinders are mounted on equipment that is stored outside for extended periods, exposed unpainted surfaces, e.g. piston rod, must be coated with a rust-inhibiting compound to prevent corrosion.

4.2 Cylinder Trouble Shooting

4.2.1 – External Leakage

4.2.1.1 – Rod seal leakage can generally be traced to worn or damaged seals. Examine the piston rod for dents, gouges or score marks, and replace piston rod if surface is rough.

Rod seal leakage could also be traced to gland wear. If clearance is excessive, replace rod bushing and seal. Rod seal leakage can also be traced to seal deterioration. If seals are soft or gummy or brittle, check compatibility of seal material with lubricant used if air cylinder, or operating fluid if hydraulic cylinder. Replace with seal material, which is compatible with these fluids. If the seals are hard or have lost elasticity, it is usually due to exposure to temperatures in excess of 165°F. (+74°C). Shield the cylinder from the heat source to limit temperature to 350°F. (+177°C.) and replace with fluorocarbon seals.

4.2.1.2 – Cylinder body seal leak can generally be traced to loose tie rods. Torque the tie rods to manufacturer's recommendation for that bore size.

Excessive pressure can also result in cylinder body seal leak. Determine maximum pressure to rated limits. Replace seals and retorquer tie rods as in paragraph above. Excessive pressure can also result in cylinder body seal leak. Determine if the pressure rating of the cylinder has been exceeded. If so, bring the operating pressure down to the rating of the cylinder and have the tie rods replaced.

Pinched or extruded cylinder body seal will also result in a leak. Replace cylinder body seal and retorquer as in paragraph above.

Cylinder body seal leakage due to loss of radial squeeze which shows up in the form of flat spots or due to wear on the O.D. or I.D. – Either of these are symptoms of normal wear due to high cycle rate or length of service. Replace seals as per paragraph above.

4.2.2 – Internal Leakage

4.2.2.1 – Piston seal leak (by-pass) 1 to 3 cubic inches per minute leakage is considered normal for piston ring construction. Virtually no static leak with lipseal type seals on piston should be expected. Piston seal wear is a usual cause of piston seal leakage. Replace seals as required.

4.2.2.2 – With lipseal type piston seals excessive back pressure due to over-adjustment of speed control valves could be a direct cause of rapid seal wear. Contamination in a hydraulic system can result in a scored cylinder bore, resulting in rapid seal wear. In either case, replace piston seals as required.

4.2.2.3 – What appears to be piston seal leak, evidenced by the fact that the cylinder drifts, is not always traceable to the piston. To make sure, it is suggested that one side of the cylinder piston be pressurized and the fluid line at the opposite port be disconnected. Observe leakage. If none is evident, seek the cause of cylinder drift in other component parts in the circuit.

4.2.3 – Cylinder Fails to Move the Load

4.2.3.1 – Pneumatic or hydraulic pressure is too low. Check the pressure at the cylinder to make sure it is to circuit requirements.

4.2.3.2 – Piston Seal Leak – Operate the valve to cycle the cylinder and observe fluid flow at valve exhaust ports at end of cylinder stroke. Replace piston seals if flow is excessive.

4.2.3.3 – Cylinder is undersized for the load – Replace cylinder with one of a larger bore size.

4.3 Erratic or Chatter Operation

4.3.1 – Excessive friction at rod gland or piston bearing due to load misalignment – Correct cylinder-to-load alignment.

4.3.2 – Cylinder sized too close to load requirements – Reduce load or install larger cylinder.

4.3.3 – Erratic operation could be traced to the difference between static and kinetic friction. Install speed control valves to provide a back pressure to control the stroke.

4.4 Cylinder Modifications, Repairs, or Failed Component – Cylinders as shipped from the factory are not to be disassembled and or modified. If cylinders require modifications, these modifications must be done at company locations or by the Company's certified facilities. The Industrial Cylinder Division Engineering Department must be notified in the event of a mechanical fracture or permanent deformation of any cylinder component (excluding seals). This includes a broken piston rod, tie rod, mounting accessory or any other cylinder component. The notification should include all operation and application details. This information will be used to provide an engineered repair that will prevent recurrence of the failure.

It is allowed to disassemble cylinders for the purpose of replacing seals or seal assemblies. However, this work must be done by strictly following all the instructions provided with the seal kits.

Miller AV Series Heavy-Duty Air Cylinders

Offer of Sale

Offer of Sale

The items described in this document and other documents and descriptions provided by Parker Hannifin Corporation, its subsidiaries and its authorized distributors ("Seller") are hereby offered for sale at prices to be established by Seller. This offer and its acceptance by any customer ("Buyer") shall be governed by all of the following Terms and Conditions. Buyer's order for any item described in its document, when communicated to Seller verbally, or in writing, shall constitute acceptance of this offer. All goods, services or work described will be referred to as "Products".

1. Terms and Conditions. Seller's willingness to offer Products, or accept an order for Products, to or from Buyer is subject to these Terms and Conditions or any newer version of the terms and conditions found on-line at www.parker.com/saleterms/. Seller objects to any contrary or additional terms or conditions of Buyer's order or any other document issued by Buyer.

2. Price Adjustments; Payments. Prices stated on Seller's quote or other documentation offered by Seller are valid for 30 days, and do not include any sales, use, or other taxes unless specifically stated. Unless otherwise specified by Seller, all prices are F.C.A. Seller's facility (INCOTERMS 2010). Payment is subject to credit approval and is due 30 days from the date of invoice or such other term as required by Seller's Credit Department, after which Buyer shall pay interest on any unpaid invoices at the rate of 1.5% per month or the maximum allowable rate under applicable law.

3. Delivery Dates; Title and Risk; Shipment. All delivery dates are approximate and Seller shall not be responsible for any damages resulting from any delay. Regardless of the manner of shipment, title to any products and risk of loss or damage shall pass to Buyer upon placement of the products with the shipment carrier at Seller's facility. Unless otherwise stated, Seller may exercise its judgment in choosing the carrier and means of delivery. No deferment of shipment at Buyers' request beyond the respective dates indicated will be made except on terms that will indemnify, defend and hold Seller harmless against all loss and additional expense. Buyer shall be responsible for any additional shipping charges incurred by Seller due to Buyer's acts or omissions.

4. Warranty. Seller warrants that the Products sold hereunder shall be free from defects in material or workmanship for a period of eighteen months from the date of delivery to Buyer. The prices charged for Seller's products are based upon the exclusive limited warranty stated above, and upon the following disclaimer: **DISCLAIMER OF WARRANTY: THIS WARRANTY COMPRISES THE SOLE AND ENTIRE WARRANTY PERTAINING TO PRODUCTS PROVIDED HEREUNDER. SELLER DISCLAIMS ALL OTHER WARRANTIES, EXPRESS AND IMPLIED, INCLUDING DESIGN, MERCHANTABILITY AND FITNESS FOR A PARTICULAR PURPOSE.**

5. Claims; Commencement of Actions. Buyer shall promptly inspect all Products upon delivery. No claims for shortages will be allowed unless reported to the Seller within 10 days of delivery. No other claims against Seller will be allowed unless asserted in writing within 30 days after delivery. Buyer shall notify Seller of any alleged breach of warranty within 30 days after the date the defect is or should have been discovered by Buyer. Any action based upon breach of this agreement or upon any other claim arising out of this sale (other than an action by Seller for an amount due on any invoice) must be commenced within 12 months from the date of the breach without regard to the date breach is discovered.

6. LIMITATION OF LIABILITY. UPON NOTIFICATION, SELLER WILL, AT ITS OPTION, REPAIR OR REPLACE A DEFECTIVE PRODUCT, OR REFUND THE PURCHASE PRICE. IN NO EVENT SHALL SELLER BE LIABLE TO BUYER FOR ANY SPECIAL, INDIRECT, INCIDENTAL OR CONSEQUENTIAL DAMAGES ARISING OUT OF, OR AS THE RESULT OF, THE SALE, DELIVERY, NON-DELIVERY, SERVICING, USE OR LOSS OF USE OF THE PRODUCTS OR ANY PART THEREOF, OR FOR ANY CHARGES OR EXPENSES OF ANY NATURE INCURRED WITHOUT SELLER'S WRITTEN CONSENT, EVEN IF SELLER HAS BEEN NEGLIGENT, WHETHER IN CONTRACT, TORT OR OTHER LEGAL THEORY. IN NO EVENT SHALL SELLER'S LIABILITY UNDER ANY CLAIM MADE BY BUYER EXCEED THE PURCHASE PRICE OF THE PRODUCTS.

7. User Responsibility. The user, through its own analysis and testing, is solely responsible for making the final selection of the system and Product and assuring that all performance, endurance, maintenance, safety and warning requirements of the application are met. The user must analyze all aspects of the application and follow applicable industry standards and Product information. If Seller provides Product or system options, the user is responsible for determining that such data and specifications are suitable and sufficient for all applications and reasonably foreseeable uses of the Products or systems.

8. Loss to Buyer's Property. Any designs, tools, patterns, materials, drawings, confidential information or equipment furnished by Buyer or any other items which become Buyer's property, will be considered obsolete and may be destroyed by Seller after two consecutive years have elapsed without Buyer ordering the items manufactured using such property. Seller shall not be responsible for any loss or damage to such property while it is in Seller's possession or control.

9. Special Tooling. A tooling charge may be imposed for any special tooling, including without limitation, dies, fixtures, molds and patterns, acquired to manufacture Products. Such special tooling shall be and remain Seller's property notwithstanding payment of any charges by Buyer. In no event will Buyer acquire any interest in apparatus belonging to Seller which is utilized in the manufacture of the Products, even if such apparatus has been specially converted or adapted for such manufacture and notwithstanding any charges paid by Buyer. Unless otherwise agreed, Seller shall have the right to alter, discard or otherwise dispose of any special tooling or other property in its sole discretion at any time.

10. Buyer's Obligation; Rights of Seller. To secure payment of all sums due or otherwise, Seller shall retain a security interest in the goods delivered and this agreement shall be deemed a Security Agreement under the Uniform Commercial Code. Buyer authorizes Seller as its attorney to execute and file on Buyer's behalf all documents Seller deems necessary to perfect its security interest.

11. Improper use and Indemnity. Buyer shall indemnify, defend, and hold Seller harmless from any claim, liability, damages, lawsuits, and costs (including attorney fees), whether for personal injury, property damage, patent, trademark or copyright

infringement or any other claim, brought by or incurred by Buyer, Buyer's employees, or any other person, arising out of: (a) improper selection, improper application or other misuse of Products purchased by Buyer from Seller; (b) any act or omission, negligent or otherwise, of Buyer; (c) Seller's use of patterns, plans, drawings, or specifications furnished by Buyer to manufacture Product; or (d) Buyer's failure to comply with these terms and conditions. Seller shall not indemnify Buyer under any circumstance except as otherwise provided.

12. Cancellations and Changes. Orders shall not be subject to cancellation or change by Buyer for any reason, except with Seller's written consent and upon terms that will indemnify, defend and hold Seller harmless against all direct, incidental and consequential loss or damage. Seller may change product features, specifications, designs and availability with notice to Buyer.

13. Limitation on Assignment. Buyer may not assign its rights or obligations under this agreement without the prior written consent of Seller.

14. Force Majeure. Seller does not assume the risk and shall not be liable for delay or failure to perform any of Seller's obligations by reason of circumstances beyond the reasonable control of Seller (hereinafter "Events of Force Majeure"). Events of Force Majeure shall include without limitation: accidents, strikes or labor disputes, acts of any government or government agency, acts of nature, delays or failures in delivery from carriers or suppliers, shortages of materials, or any other cause beyond Seller's reasonable control.

15. Waiver and Severability. Failure to enforce any provision of this agreement will not waive that provision nor will any such failure prejudice Seller's right to enforce that provision in the future. Invalidation of any provision of this agreement by legislation or other rule of law shall not invalidate any other provision herein. The remaining provisions of this agreement will remain in full force and effect.

16. Termination. Seller may terminate this agreement for any reason and at any time by giving Buyer thirty (30) days written notice of termination. Seller may immediately terminate this agreement, in writing, if Buyer: (a) commits a breach of any provision of this agreement (b) appoints a trustee, receiver or custodian for all or any part of Buyer's property (c) files a petition for relief in bankruptcy on its own behalf, or by a third party (d) makes an assignment for the benefit of creditors, or (e) dissolves or liquidates all or a majority of its assets.

17. Governing Law. This agreement and the sale and delivery of all Products hereunder shall be deemed to have taken place in and shall be governed and construed in accordance with the laws of the State of Ohio, as applicable to contracts executed and wholly performed therein and without regard to conflicts of laws principles. Buyer irrevocably agrees and consents to the exclusive jurisdiction and venue of the courts of Cuyahoga County, Ohio with respect to any dispute, controversy or claim arising out of or relating to this agreement.

18. Indemnity for Infringement of Intellectual Property Rights. Seller shall have no liability for infringement of any patents, trademarks, copyrights, trade dress, trade secrets or similar rights except as provided in this Section. Seller will defend and indemnify Buyer against allegations of infringement of U.S. patents, U.S. trademarks, copyrights, trade dress and trade secrets ("Intellectual Property Rights"). Seller will defend at its expense and will pay the cost of any settlement or damages awarded in an action brought against Buyer based on an allegation that a Product sold pursuant to this Agreement infringes the Intellectual Property Rights of a third party. Seller's obligation to defend and indemnify Buyer is contingent on Buyer notifying Seller within ten (10) days after Buyer becomes aware of such allegations of infringement, and Seller having sole control over the defense of any allegations or actions including all negotiations for settlement or compromise. If a Product is subject to a claim that it infringes the Intellectual Property Rights of a third party, Seller may, at its sole expense and option, procure for Buyer the right to continue using the Product, replace or modify the Product so as to make it noninfringing, or offer to accept return of the Product and return the purchase price less a reasonable allowance for depreciation. Notwithstanding the foregoing, Seller shall have no liability for claims of infringement based on information provided by Buyer, or directed to Products delivered hereunder for which the designs are specified in whole or part by Buyer, or infringements resulting from the modification, combination or use in a system of any Product sold hereunder. The foregoing provisions of this Section shall constitute Seller's sole and exclusive liability and Buyer's sole and exclusive remedy for infringement of Intellectual Property Rights.

19. Entire Agreement. This agreement contains the entire agreement between the Buyer and Seller and constitutes the final, complete and exclusive expression of the terms of sale. All prior or contemporaneous written or oral agreements or negotiations with respect to the subject matter are herein merged.

20. Compliance with Law, U. K. Bribery Act and U.S. Foreign Corrupt Practices Act. Buyer agrees to comply with all applicable laws and regulations, including both those of the United Kingdom and the United States of America, and of the country or countries of the Territory in which Buyer may operate, including without limitation the U. K. Bribery Act, the U.S. Foreign Corrupt Practices Act ("FCPA") and the U.S. Anti-Kickback Act (the "Anti-Kickback Act"), and agrees to indemnify and hold harmless Seller from the consequences of any violation of such provisions by Buyer, its employees or agents. Buyer acknowledges that they are familiar with the provisions of the U. K. Bribery Act, the FCPA and the Anti-Kickback Act, and certifies that Buyer will adhere to the requirements thereof. In particular, Buyer represents and agrees that Buyer shall not make any payment or give anything of value, directly or indirectly to any governmental official, any foreign political party or official thereof, any candidate for foreign political office, or any commercial entity or person, for the purpose of influencing such person to purchase products or otherwise benefit the business of Seller.

Miller Fluid Power

500 South Wolf Road
Des Plaines, IL 60016 USA
Tel.: (847) 298-2400
Fax: (800) 892-1008
E-mail: MFPCyImktg@parker.com
Website: www.miller-fluidpower.com

Miller Fluid Power

160 Chisholm Drive
Milton, Ontario
Canada L9T 3G9
Tel.: (905) 693-3000
Fax: (905) 876-1958

All specifications and information subject to
change without notice or prior obligation.

Catalog M0910-4
01/2014

