

FCI® AND VORTAB®:

Proven Partners

for Accurate

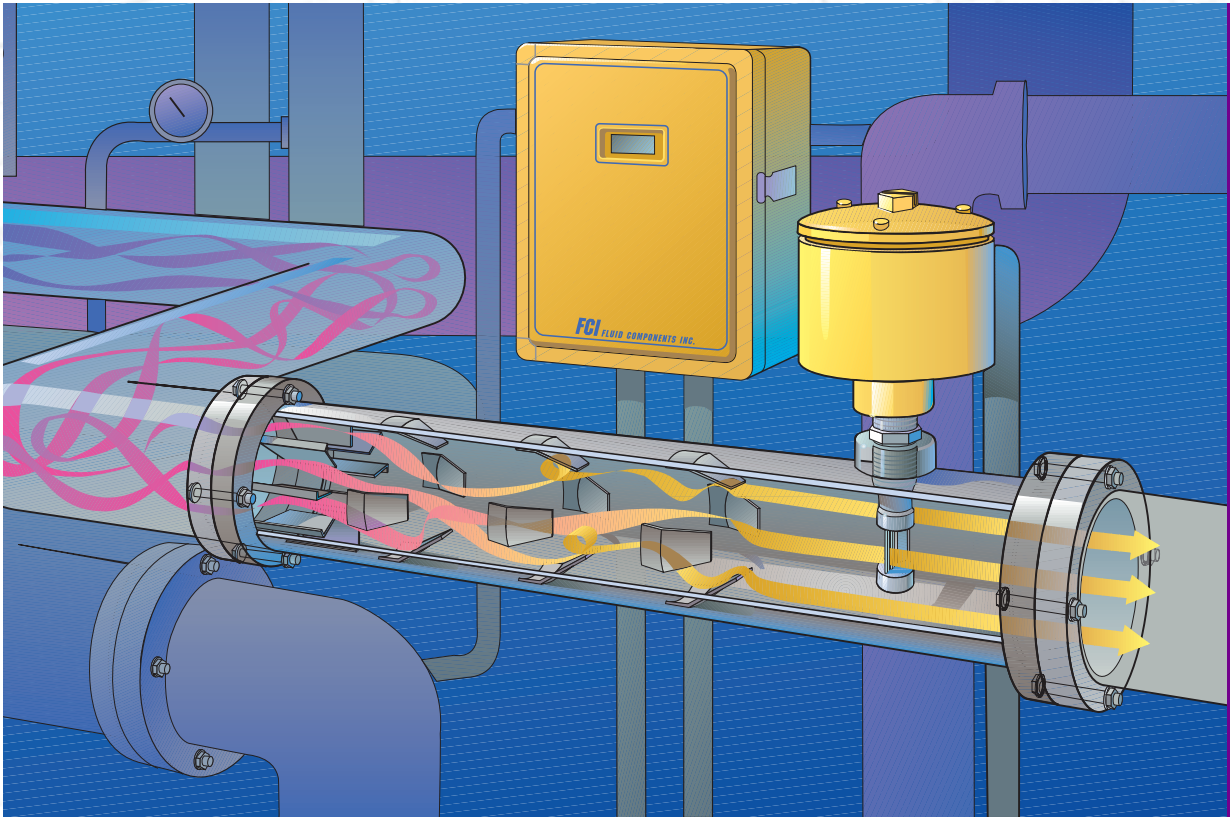

FCI AND VORTAB®

Gas Mass Flow

Measurement

FCI FLUID COMPONENTS
INTERNATIONAL LLC

Fluid Components Intl and Vortab Company have formed an exclusive partnership to provide a lower cost, reliable, high performance solution for accurate mass flowmetering in gas applications. The new FCI/Vortab flow metering system combines FCI's field-proven thermal gas mass flow meters with Vortab's patented low pressure loss flow conditioners.

FCI Flow Meters | Since 1964, FCI has provided high performance thermal flow sensing for tough applications in the processing, nuclear and fossil fuel power, wastewater treatment and aerospace industries. All FCI flow meters feature FCI's thermal dispersion operating principle providing stable performance, high reliability and low flow sensitivity. FCI's no-moving parts design ensures dependable, virtually maintenance-free performance in harsh, dirty and explosive gas mass flow metering applications. Microprocessor-based electronics add increased flexibility to FCI's mass flow meters permitting user-friendly operations and maintenance, easy in-field adjustment of zero, span and display units, and built-in testing and self-diagnostics.

Vortab Flow Conditioners | Vortab flow conditioners provide a low pressure loss solution to flow profile irregularities produced by elbows, valves, blowers, compressors, and other disruptions that commonly occur in pipe and duct runs. By eliminating flow profile irregularities and temperature or media stratification, they ensure accurate, repeatable gas flow measurement and are the efficient alternative to long lengths of straight piping or ducting upstream from a flowmeter. Vortab flow conditioners provide the most thorough conditioning, in a shorter distance, with a fraction of the pressure loss of any other flow straightener or conditioner available today.

Performance from Teamwork | By teaming FCI's proven thermal dispersion mass flow metering experience and products with Vortab flow conditioners, FCI now provides unequalled gas mass flow metering performance in applications previously considered too difficult or impractical to meter.

The Vortab flow conditioner, located just three (3) diameters upstream of the FCI flow meter installation, virtually eliminates gas flow swirl and velocity profile distortions as well as temperature and media stratification produced by process equipment obstructions and/or inadequate straight run of pipe and ducting. This results in tremendous flowmetering accuracy and repeatability improvements. The FCI/Vortab team provides the ideal solution for industry's toughest, most critical gas mass flow metering applications.

Proven Flow Conditioning Technology | Vortab flow conditioners uniquely combine proven swirl removal technology with the patented Vortab mixing process to achieve the most thorough and efficient flow conditioning available. Each of the three available flow conditioner configurations consists of a short section of swirl reduction tabs combined with three (3) arrays of Vortab profile conditioning tabs. This design produces: rapid cross-stream mixing; minimizes swirl and velocity profile distortions; produces flow profile repeatability across a broad flow range.

Equally important, Vortab flow conditioners feature a patented low pressure loss design. Non-recoverable pressure loss can reduce maximum flow capability in process lines, creating process inefficiencies and requiring greater energy expenditures to move process gases. Perforated plates, tube bundles, screens and other flow conditioning technologies produce a much greater pressure loss than Vortab flow conditioners and, unlike Vortab flow conditioners, are subject to clogging or fouling in industrial applications.

The patented Vortab technology provides unmatched performance with little pressure loss and swirl-free, conditioned flow profile. It is the ideal partner for FCI's low pressure loss, centerline mounted single-point and equal area multi-point sensor technology.

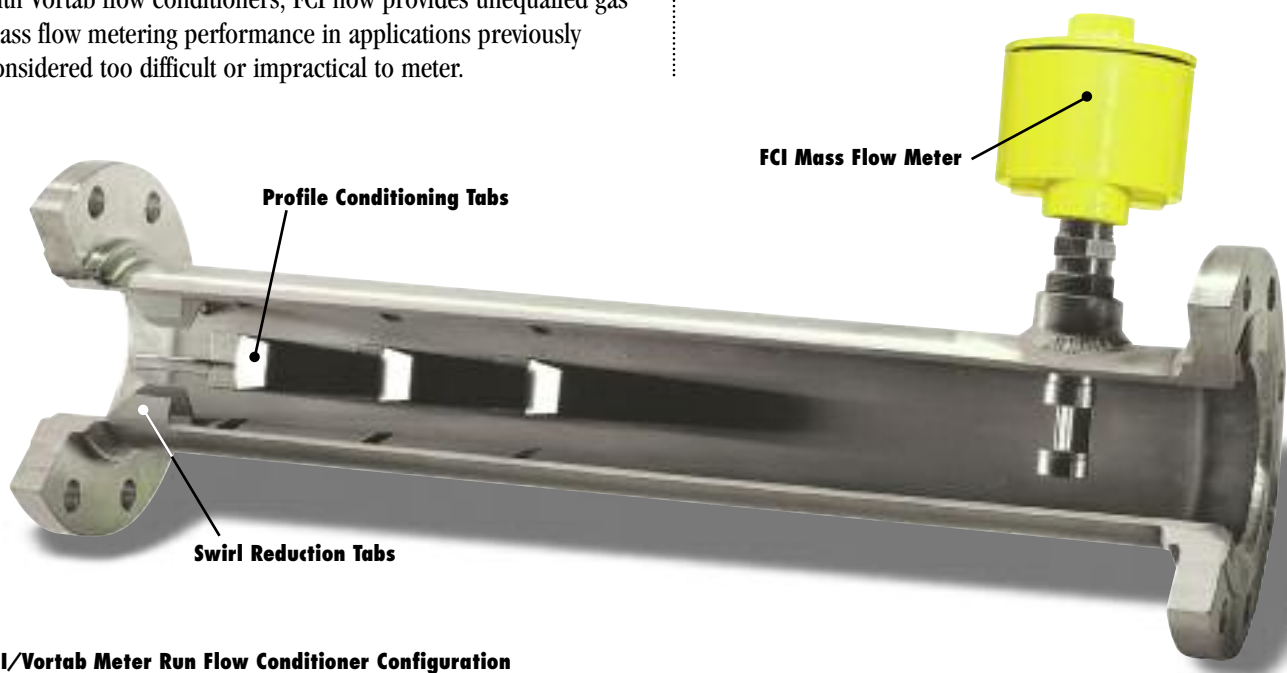

FCI/Vortab Meter Run Flow Conditioner Configuration

Economic, Flexible Installation To meet industry's demand for installation flexibility, ease and economy, the FCI/Vortab flow conditioning system is available in three configurations (see outline dimension drawings on the back page):

1.) Meter Run Configuration. The Meter Run configuration (VMR) offers a complete, simple pipe section replacement for new and existing piping systems. The Vortab flow conditioners is precisely located three (3) diameters upstream of the FCI flow meter port in a seven (7) (eight [8] with 2 inch pipe) diameters long built-in pipe section: A variety of end connections and pipe sizes from 2 inches to 12 inches [51 mm to 305 mm] are available.

2.) Insertion Sleeve Configuration. The Insertion Sleeve configuration (VIS) allows for direct mounting in existing or specially sized pipe sections. The swirl and conditioning tabs are connected to a mounting sleeve that slides into the process piping. Attachment methods include welded-in-place or captured flange designs.

3.) Field Kit Configuration. The Field Kit configuration (VFK) is designed for use in very large ducts and piping, square ducts and irregular shaped installations. The kit comes complete with separate profile conditioning and swirl reduction tabs that have been sized for the specific application. Complete instructions are included to permit easy, permanent field installation.

Performance Improvement Highlights **50% Gate Valve Closure Seven (7) Diameters Upstream of Metering Location.** Considered to be among the most difficult installation locations, a 50% gate valve closure produces severe flow profile distortions that vary in intensity throughout the flow range of the installation. Such flow profile distortions can produce severe flowmeter accuracy degradation. However, a highly accurate and reliable mass flow rate measurement can be achieved in this application with the installation of an FCI/Vortab flow metering system.

The installation of a Vortab flow conditioner downstream of the gate valve and three diameters upstream of the FCI flow meter as shown in Graph A, provides a virtually ideal flow profile for the FCI flow meter. Consequently, FCI's thermal mass flow meter is able to provide flow rate accuracy and repeatability approaching the performance characteristics associated with ideal installations that typically require up to four times more straight run.

Standard Elbow Seven (7) Diameters Upstream of Metering Location. Frequently encountered in flow meter installations, elbows and double elbows (either in-plane or out-of-plane) can produce flow profile irregularities that limit flow meter accuracy. Vortab flow conditioner used in conjunction with an FCI mass flow meter revolutionizes flowmeter performance for this difficult installation. The result is exceptional instrument accuracy, repeatability and reliability.

For tough applications with flow profile distortions ranging from subtle to severe, depend on the teamwork of proven industry leaders FCI and Vortab – a smart partnership built for industry leadership.

Graph A: 1/2 Open Disturbance – Vortab vs. No Flow Conditioner ST95 in a 4" line

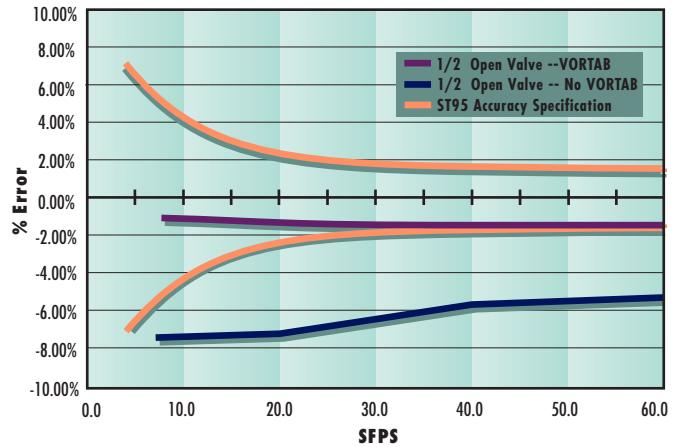

Graph B: Two Elbow Disturbance – Vortab vs. No Flow Conditioner ST95 in a 4" line

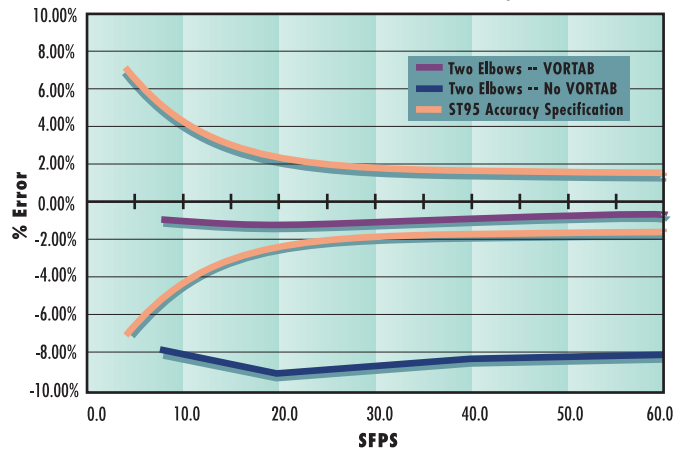

Graph C: Pressure Loss Versus Flow Rate

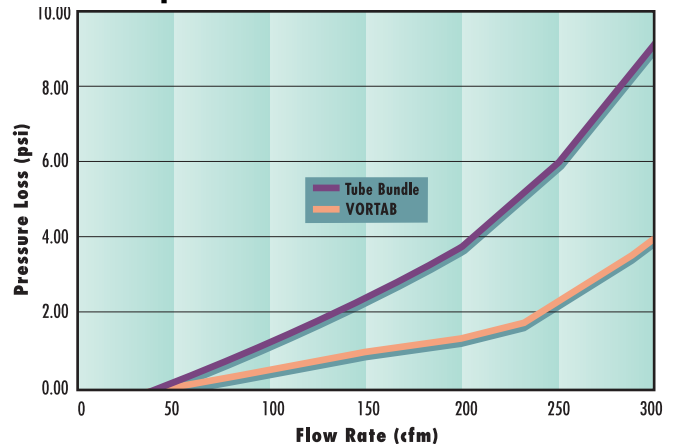

ΔP Equation for Air at Standard Conditions (60°F, 0 psig):

$$\Delta P = 6.8 \times 10^{-5} \times \frac{Q^2}{D^4} \text{ or } 3.36 \times 10^{-6} \times \frac{M^2}{D^4}$$

ΔP Equation for Water:

$$\Delta P = 5.66 \times 10^{-2} \times \frac{Q^2}{D^4} \text{ or } 4.04 \times 10^{-9} \times \frac{M^2}{D^4} \text{ or } 1.01 \times 10^{-3} \times \frac{G^2}{D^4}$$

Where ΔP is in pounds per square inch (psi); Q is the volumetric flow rate in cubic feet per minute (cfm); M is the mass flow rate in pounds per hour (lb_m/hr); G is the flow rate in gallons per minute (gpm); D is the inside pipe diameter in inches.

FCI/VORTAB Flow Conditioner Specifications

Meter Run Flow Conditioner (VMR)

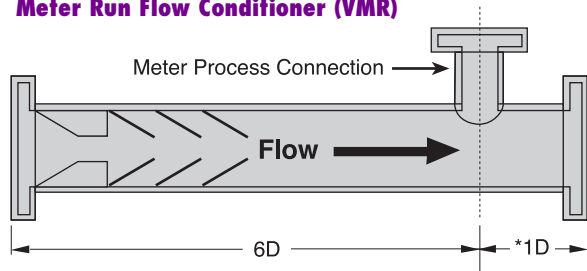

Insertion Sleeve Flow Conditioner (VIS)

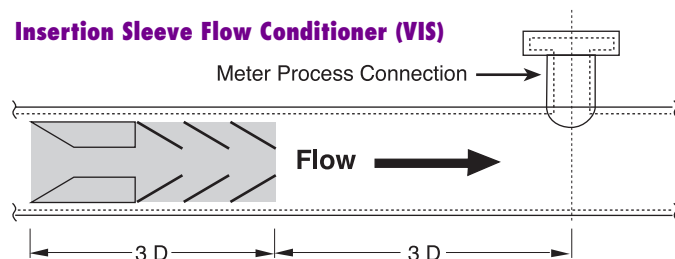

Field Kit Flow Conditioner (VFK)

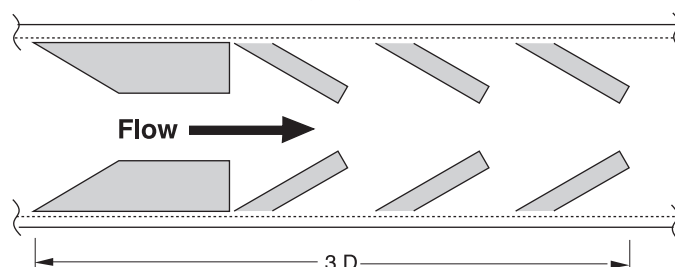

D = Nominal Pipe Diameter

*2D used for 2" size with flanged meter process connection.

Application:

High accuracy air and gas flow measurement in applications with irregular flow profiles and minimum upstream runs of piping or ducting.

Meter Run Flow Conditioner (VMR): A pipe section replacement (spool piece) that includes an FCI flow meter mounting connection.

Insertion Sleeve Flow Conditioner (VIS): An assembly that slides into existing or specially sized pipe sections.

Field Kit Flow Conditioner (VFK): A set of swirl reduction and profile conditioning tabs.

Material of Construction (for all models): 316L stainless steel, carbon steel, Hastelloy C-276, or other materials of construction available.

Maximum Flow Velocity:

Air: 300 ft/sec [91 m/sec]

Water: 30 ft/sec [9,1 m/sec]

(Consult factory for applications that exceed these limits.)

Meter Run Flow Conditioner:

Pipe Size: Standard sizes of 2", 3", 4", 6", 8", 10" and 12" diameter configurations. Larger sizes are available.

Pipe Schedule: Schedule 40 or 80 are standard, not limitations.

Process Connections: Weld preparation, NPT through 4 inch sizes, or flanged (customer supplied or ANSI 150#, 300#, or 600# serrated with raised faces).

Flow Meter Connection: Female threaded (3/4, 1, or 1-1/4 inch NPT), 1-1/4 inch male threaded NPT, or flanged (1-1/2 inch ANSI 150#, 300#, or contact manufacturer for special flange sizes).

Meter Run Length: 7 pipe diameters (except the 2" size with flanged meter process connection, which is 8 pipe diameters).

Insertion Sleeve Flow Conditioner:

Pipe Diameter: Customer specified from 0.87" to 48" [22 mm to 1220 mm].

Attachment Method: Welded-in-place or captured flange.

Flow Conditioner Length: 3 pipe diameters.

Field Kit Flow Conditioner:

Nominal Pipe/Duct Size: 36" [914 mm] and larger.

Attachment Method: Welded-in-place.

Flow Conditioner Length: 3 pipe diameters.

Note: Contact FCI for custom configurations.

FCI's Instrument User's Protection Plan

Guaranteed Performance. FCI guarantees performance of its entire product line -- including the FCI/Vortab flow metering system, mass flow meters, flow switch/monitors, and liquid level and interface controllers -- in accepted applications or your money back.

1-Year Warranty. FCI warrants its products against faulty materials

or workmanship for one full year from the date of delivery to the buyer. (Ask for a copy of our complete warranty.)

Customer Service. FCI commits itself to providing prompt, 24 hour customer service including expedited field service and repair support, and toll-free factory service.



Web: www.fluidcomponents.com | **Email:** fcimarcom@fluidcomponents.com

1755 La Costa Meadows Drive, San Marcos, California 92078 USA | **Phone:** 760-744-6950 | **Toll free (US):** 800-854-1993 | **Fax:** 760-736-6250

European Office: Persephonestraat 3-01 5047 TT Tilburg, The Netherlands | **Phone:** 31-13-5159989 | **Fax:** 31-13-5799036

FCI is ISO 9001:2000 and AS9100 certified



1755 La Costa Meadows Drive
 San Marcos, CA 92078 USA
 800-854-9959 / Fax 760-736-6250
 www.vortab.com

VORTAB

Flow Conditioners

| | | | | | | | | | | | |
|---|---|---|---|---|---|---|---|---|----|----|--|
| V | | | | | | | | | | | |
| 1 | 2 | 3 | 4 | 5 | 6 | 7 | 8 | 9 | 10 | 11 | |

Special Instructions

Box No. Code W or * Description ¹

INSTRUCTIONS: To order a Vortab, please fill-in each numbered box above with the appropriate code from the categories below. Once you have made all selections, contact a VORTAB Company Representative for price and delivery information. Contact the VORTAB Company on the availability of other options and special applications. Final acceptance of the part number is subject to the VORTAB's approval.

| 1. - 3. Model | Code |
|--|------|
| VIS Insertion Sleeve For use inside pipes or round ducts from 1 to 48 inches in diameter. Standard length is 3 inside diameters. | VIS |
| VMR Meter Run For connection to piping from 2 to 24 inches in diameter. Standard length is 7 nominal diameters. 2 inch size with flow element connection and flanged process connections are 8 nominal pipe diameters. | VMR |
| VSR Short Run For connection to piping from 2 to 24 inches in diameter. Standard length is 3 nominal diameters. | VSR |
| VEL 90° Long Radius Elbow For connection to piping from 1 to 36 inches in diameter. | VEL |
| Field Kit For assembly and installation inside round or square pipes or ducts from 36 to 96 inches in diameter or size | VFK |

| 8. All Welded Material of Construction | Code |
|--|------|
| Carbon steel - For VIS Model with inside diameter greater than 4.51 inches. - For VMR or VSR Model with nominal pipe size 8 inches or larger. - For VEL and VFK Models, all pipe sizes. | 1 |
| 316 Stainless steel - For all Models. | 2 |
| 316 Stainless steel body with carbon steel flanges - For VMR and VSR Models only. | 3 |
| <i>Note: Codes 5 or 6 must be selected in Box 9. Codes 6 or 8 must be selected in Box 10 when a flow element is required.</i> | |
| Hastelloy C-276 - For VIS or VFK Models only. | 4 |
| Other ¹ | * |

| 10. Flow Element Connection | Code |
|--|------|
| For VIS, VSR, VEL and VFK Models None (Standard) | 0 |
| For VMR Model only 3/4 inch Female NPT | 1 |
| 1 inch Female NPT | 2 |
| 1-1/4 inch Female NPT | 3 |
| 1-1/4 inch Male NPT (See Figure 5) | 4 |
| 1-1/2 inch ANSI flange ³ (See Figure 4) | |
| 150 lb. Stainless steel | 5 |
| 150 lb. Carbon steel | 6 |
| 300 lb. Stainless steel | 7 |
| 300 lb. Carbon steel | 8 |
| Other ¹ | * |

| 4. - 7. Pipe or Duct Size | | | | | | | | |
|---|---------------|------|-------|----|--------|----|----|----|
| <p>Enter all dimensions in Inches. Dimensions must be rounded down to the nearest hundredth of an inch. Divide millimeters by 25.4 to convert to inches.</p> | | | | | | | | |
| For VIS Model In Boxes 4 through 7, enter the inside diameter from 00.87 inch to 48.00 inches. | | | | | | | | |
| For VMR, VSR and VEL Models ² In Boxes 4 and 5, enter the nominal pipe size in inches. <i>For VMR and VSR</i> Carbon steel = 08 to 24 inches Stainless steel = 02 to 24 inches <i>For VEL</i> Carbon steel = 01 to 36 inches Stainless steel = 01 to 36 inches In Boxes 6 and 7, enter the pipe schedule code: <i>For VMR, VSR and VEL</i> | | | | | | | | |
| <table border="1"> <thead> <tr> <th>Schedule</th> <th>Code</th> </tr> </thead> <tbody> <tr> <td>STD</td> <td>00</td> </tr> <tr> <td>10</td> <td>S1</td> </tr> <tr> <td>80</td> <td>S8</td> </tr> </tbody> </table> | Schedule | Code | STD | 00 | 10 | S1 | 80 | S8 |
| Schedule | Code | | | | | | | |
| STD | 00 | | | | | | | |
| 10 | S1 | | | | | | | |
| 80 | S8 | | | | | | | |
| For VFK Model In Boxes 4 and 5, enter the inside diameter (ID) or dimension from 36 to 96 inches In Boxes 6 and 7, enter the pipe geometry code: | | | | | | | | |
| <table border="1"> <thead> <tr> <th>Pipe Geometry</th> <th>Code</th> </tr> </thead> <tbody> <tr> <td>Round</td> <td>RD</td> </tr> <tr> <td>Square</td> <td>SQ</td> </tr> </tbody> </table> | Pipe Geometry | Code | Round | RD | Square | SQ | | |
| Pipe Geometry | Code | | | | | | | |
| Round | RD | | | | | | | |
| Square | SQ | | | | | | | |

| 9. Process Connection | Code |
|---|------|
| None (See Figure 1) - For VIS or VFK Models only. | 0 |
| Retaining wafer at inlet (See Figure 2) - For VIS Model only. | 1 |
| Retaining wafer at outlet - For VIS Model only. | 2 |
| Butt weld preparation (See Figures 4,7,9,10) - For VMR, VSR and VEL Models only. | 3 |
| Male NPT (See Figures 3 and 7) - For VMR, VSR and VEL Models only with 2 to 4 inch pipe sizes. | 4 |
| ANSI flanges ³ (See Figures 5, 6, 8) - For VMR, VSR and VEL Models only. Flange size is determined by the Codes selected in Boxes 4 and 5. Materials of construction are determined by the Codes selected in Box 8. | |
| 150 lb | 5 |
| 300 lb | 6 |
| Other ¹ | * |

| 11. Identification Tag ⁴ | Code |
|---|------|
| None (VIS Models Only) | 0 |
| For VMR, VSR and VEL Models only Adhesive label | 1 |
| Adhesive label and stainless steel tag | 2 |
| Other ¹ | * |

Notes

- Describe the desired pipe schedule, material of construction, process connection, flow element connection, or identification tag. Contact the VORTAB Company for availability, pricing, and delivery.
- The VMR, VSR and VEL Models use standard wall thickness pipe (STD). For pipe sizes from 2 to 10 inches, STD pipe is equivalent to schedule 40 or 40S pipe. For pipe sizes from 12 to 36 inches, STD pipe has a 0.375 inch [9.5 mm] wall thickness.
- All flanges are raised face and phonographic serrated. VMR and VSR Models use slip-on flanges. VEL Model uses welding neck flanges.
- Stainless steel tag must not exceed 5 lines with 18 characters per line.

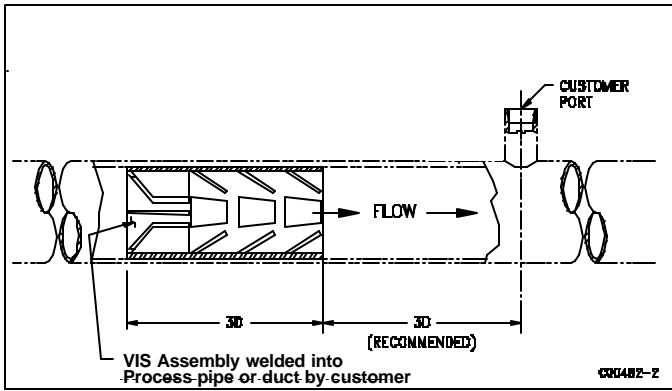

Figure 1. VIS without Retaining Wafer

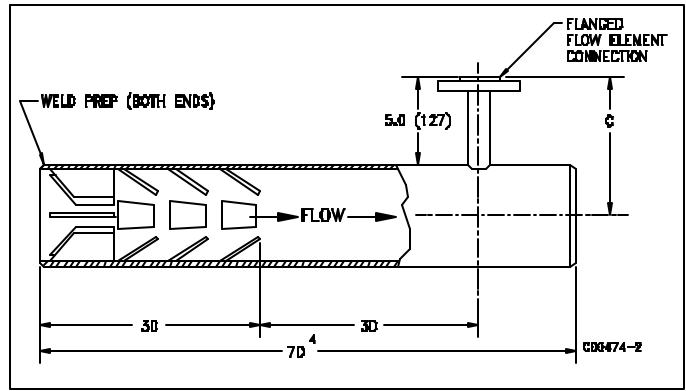

Figure 4. VMR with Butt Weld Preparation Process Connections and Flanged Flow Element Connection

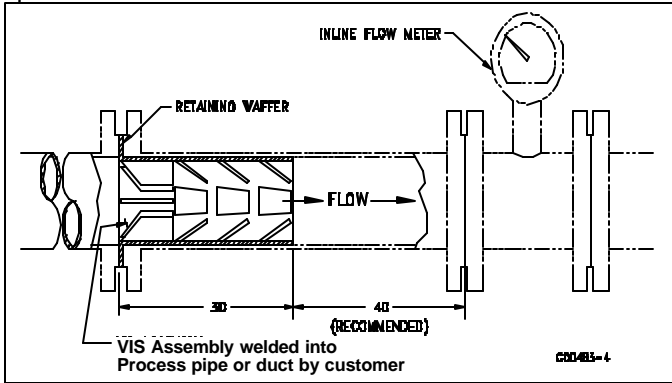

Figure 2. VIS with Retaining Wafer at Inlet

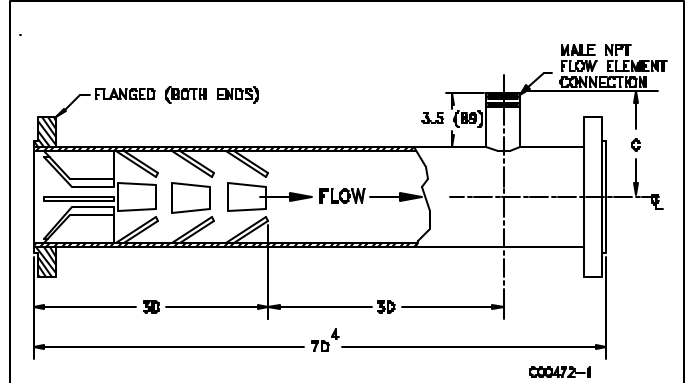

Figure 5. VMR with Flanged Process Connections and Male NPT Flow Element Connection

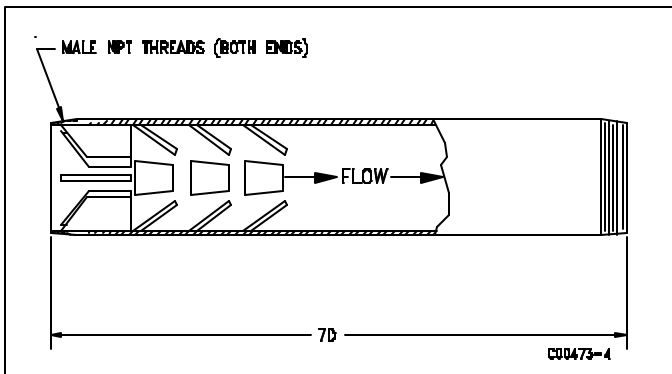

Figure 3. VMR with Male NPT Process Connections and No Flow Element Connection

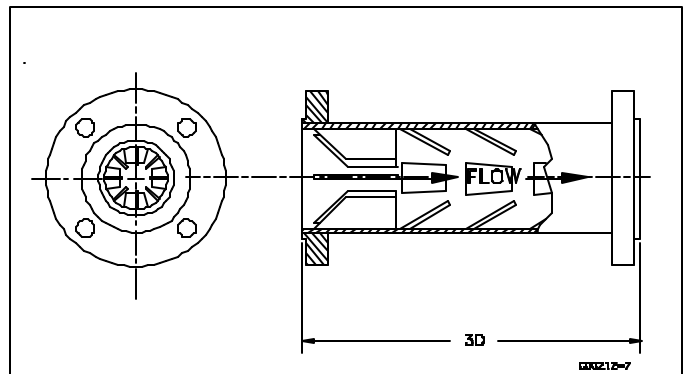

Figure 6. VSR with Flanged Process Connections

| Table A: Flow Element Connections | | | | | | |
|-----------------------------------|--|-------------|------------------------|-------------|--|--------------|
| VMR Size | For FCI Flowmeters (U-Length) ³ | | | | All Other Instruments (C) ² | |
| | Threaded | | Flanged | | Threaded | Flanged |
| | ST Series | GF Series | ST Series | GF Series | | |
| 2" | | 4.7" [119] | | 6.9" [175] | 4.69" [119] | 6.19" [157] |
| 3" | 1" - 6" [25 - 152] | 5.8" [147] | 1" - 6" [25 - 152] | 7.8" [198] | 5.25" [133] | 6.75" [171] |
| 4" | | 6.3" [160] | | 8.3" [211] | 5.75" [146] | 7.25" [184] |
| 6" | 1" - 12" [25 - 305] | 7.3" [185] | 1" - 12" [25 - 305] | 9.3" [236] | 6.81" [173] | 8.31" [211] |
| 8" | | 8.3" [211] | | 10.3" [262] | 7.81" [198] | 9.31" [236] |
| 10" | | 9.4" [239] | | 11.4" [290] | 8.87" [225] | 10.37" [264] |
| 12" | | 10.4" [264] | | 12.4" [315] | 9.87" [251] | 11.37" [289] |

Notes

- "D" equals the nominal pipe size or diameter and "xD" equals the pipe length in terms of the equivalent number of nominal pipe diameters.
- "C" is the distance from the flow element connection to the centerline of the VMR. Find the dimension of "C" in Table A and use to calculate the length of your insertion flowmeter in accordance with the flowmeter manufacturer's specified guidelines.
- U-length calculations do not include the additional length required for special flow element connections such as ball valves, extended nozzles, etc.
- 2 inch sizes with a flow element connection and flanged process connections require 8 nominal pipe diameters in length.

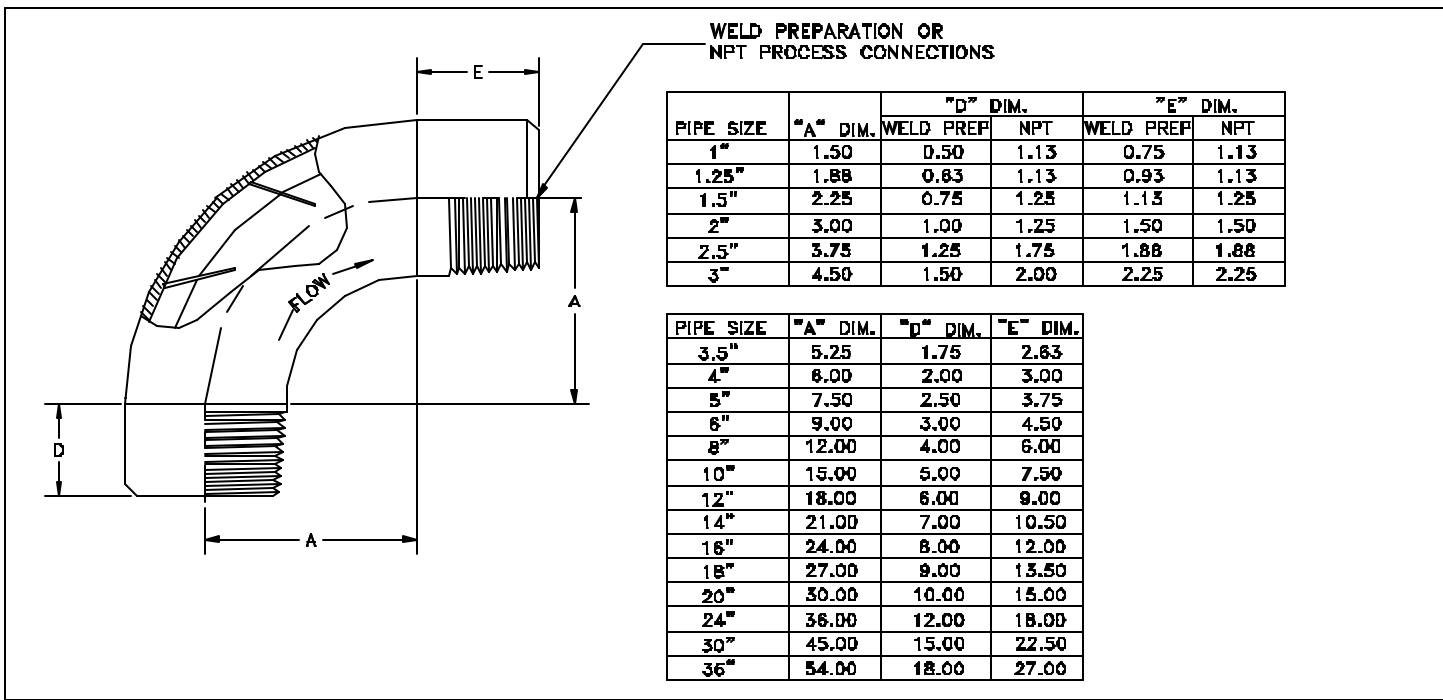

Figure 7. VEL with MNPT or Weld Preparation Process Connections

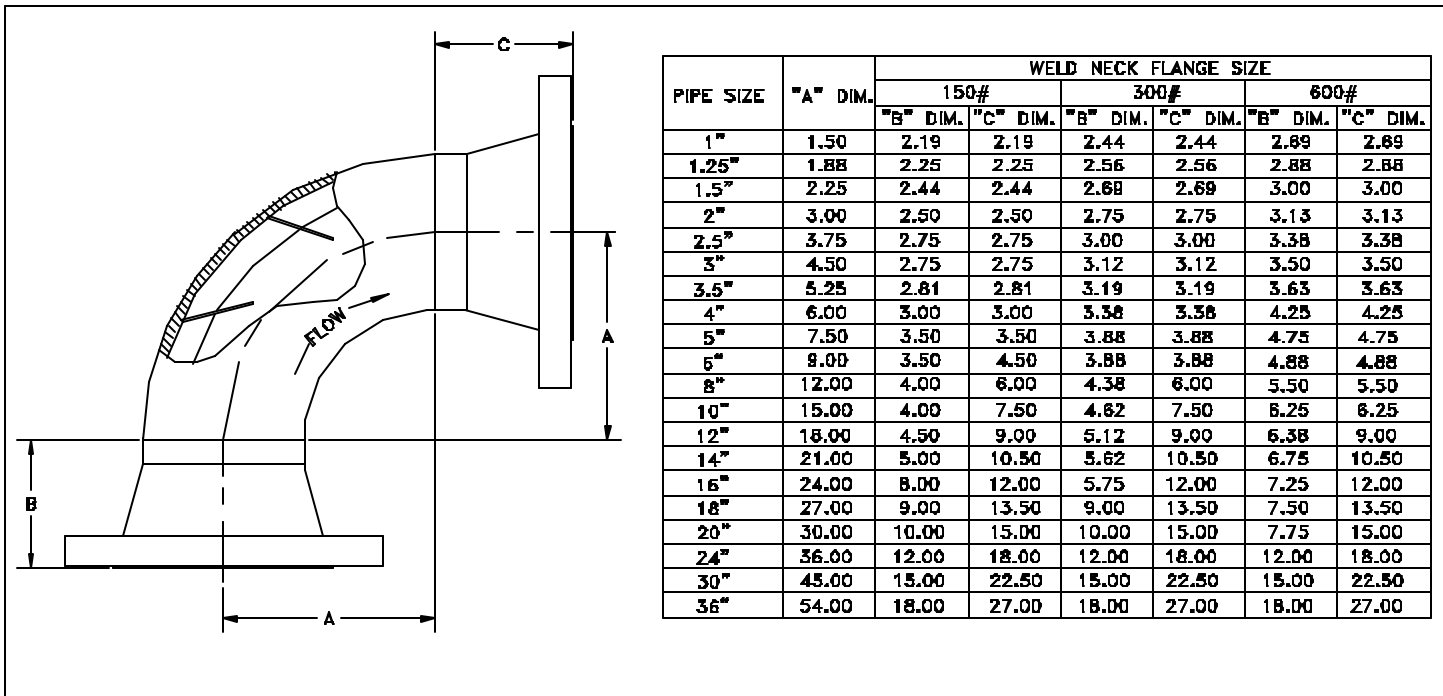

Figure 8. VEL with Flanged Process Connections

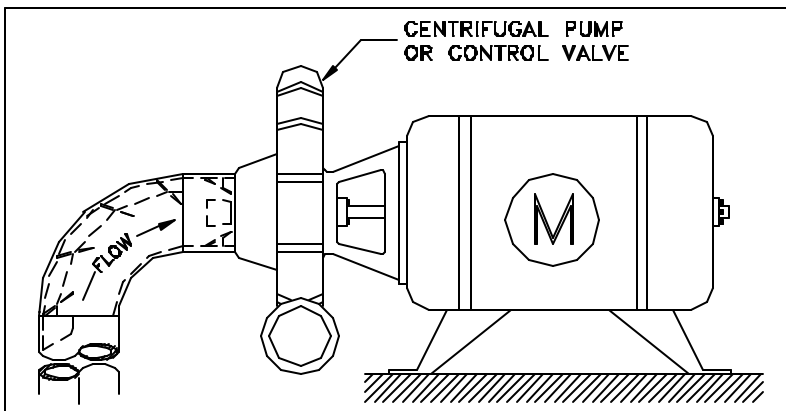

Figure 9. Typical Process Application

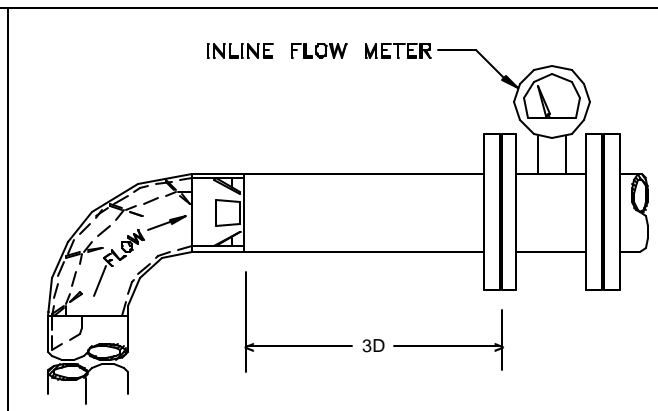

Figure 10. Typical Flowmeter Application