

Thermal Dispersion Air/Gas Insertion Flow Meter



The Model ST110 flow meter combines a broad selection of insertion-type flow elements with best-in-class transmitter/electronics, superior calibration and FCI's exclusive patented VeriCal system. VeriCal provides you with the ability to perform periodic field validation and verification of the flow meter's measuring performance and calibration without extracting the flow meter from the pipe or process.

Flow Element and Process Connections

- All welded construction
- 316L stainless steel or Hastelloy-C276
- Fast response and extra-rugged duty choices
- Variable (adjustable) and fixed insertion depths
- NPT, flanges, hot-tap retractable packing gland connections

Transmitter and Electronics

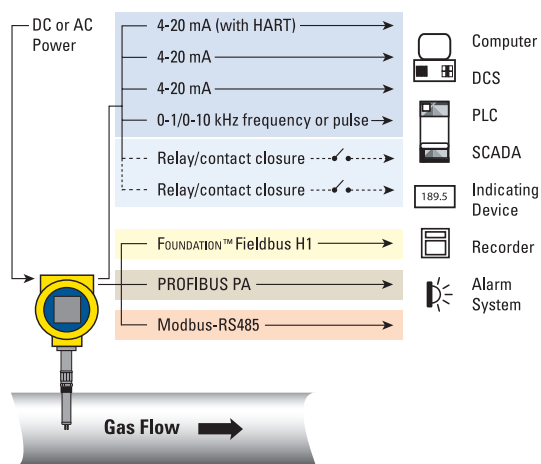

Model ST110 Features

- **Validate Performance On-Site in Minutes**
 - **Save Costs, No Need to Remove Flow Meter from Process**
 - **Comply with ISO and Local Regulations for Periodic Calibration Verification**
 - **Compatible with More than 200 Gases**
 - **Direct Mass Flow Measurement**
 - **Dual Function – Flow and Temperature**
 - **Temperature Service to 500 °F [260 °C]**
 - **No Moving Parts, Non-Clogging**
 - **Easy, Low Cost Single Point Insertion**
 - **Best-In-Class Digital/Graphical Readout**
 - **Multiple Analog Outputs**
 - **Extensive Bus Communications Options**
 - **Agency Approvals on Full Instrument**
 - **Provides In-Situ Flow Element Cleaning**
 - **On-Board Data Logger**
- All metal enclosure
 - Four (4) conduit ports
 - 2" x 2" [50 mm x 50 mm] backlit LCD readout/display
 - Flow, total flow and temperature
 - Triple analog outputs with HART
 - FOUNDATION™ fieldbus, PROFIBUS PA, Modbus options
 - Dual relays/alarms option
 - Integral or remote mounting (up to 1000')
 - AC or DC power
 - FM, FMc, ATEX and IECEx approvals for Division 1, Zone 1 hazardous locations
 - Standard and extended range temperature compensation
 - Data logging to removable micro-SD card

Calibration

- Calibrated to your installation conditions and gas specifications on one of 18 precision, NIST traceable flow stands
- Up to five (5) unique calibrations stored onboard
- SpectraCal™ – 10 user selectable / changeable gases

Model ST110 Features

Four conduit ports provide greatest signal integrity and separation for power input, analog output lines, digital I/O, relays and/or auxiliary input signals; choice of NPT or M20 threads

AC or DC power supply

Weather-proof, ruggedized, Ex rated enclosures

- Choices for local or remote mounting
- NEMA 4X, IP67

Global agency approvals of entire instrument system for hazardous location installations:

FM, FMc, ATEX, IEC, NEPSI, CPA
NEPSI, CPA, Inmetro, GOST-R, GOST-K pending

Multiple calibrations

- Up to five independent, separate calibrations
- Multiple gases or mixed gas compositions
- Same gas, different flow range to optimize accuracy and extend turndown up to 1000:1

Precision calibration and calibration choices

- Specific gas and application matched calibration in FCI NIST traceable facility
- Exclusive patented SpectraCal gas equivalency calibration with ten (10) user selectable gases

Extensive analog and digital communications output choices

- Triple 4-20 mA with HART
- FOUNDATION™ fieldbus H1
- PROFIBUS PA
- Modbus RS-485
- 0-1 kHz or 0-10 kHz frequency or pulse
- Dual relays
- USB port
- Ethernet

On-board data logger

Multi-function: measures mass flow rate and temperature

Four (4) optical touch buttons

- Proximity activation, no need to open enclosure
- Full instrument programmability
- Protected against unwanted activation

Comprehensive informational display

- Digital readout of all measured parameters; flow rate, total flow, temperature and pressure with engineering units
- Analog flow rate bar graph
- Alarm relay status indication
- Instrument fault indication
- User programmable 17 character field (example: display gas type, tag number or application/location)
- Display orientation rotates in 90° increments electronically
- Backlighted: auto-on activation via proximity sensor or set for always on

VeriCal or Normal Operation valve

Sonic nozzle

VeriCal one-way inlet valve



ST Series retractable flow element with VeriCal fittings

Stainless steel or Hastelloy-C276 wetted parts

All welded sensor elements for maximum service life and leak-proofing

Precision, wide-ranging platinum RTD sensors

Exclusive equal mass sensors provide optimum performance in processes with wide temperature swings

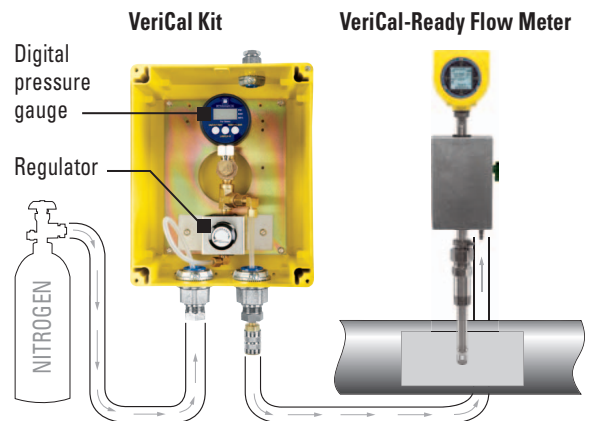

Nitrogen and hose user supplied; VeriCal kit shown with cover removed

Model ST110 Single-Point Insertion Mass Flow Meter Specifications

Instrument

- **Measuring Capability:** Flow rate, total flow and temperature
- **Basic Style:** Insertion, single element with VeriCal™ capability
- **Flow Measurement Range:** 0.25 SFPS to 600 SFPS [0,07 NMPS to 172 NMPS]
– Air at standard conditions; 70 °F and 14.7 psia [0 °C and 1013,25 bar(a)]
- **Temperature Measurement Range:** Up to 500 °F [260 °C]
commensurate with element; *see operating temperature in flow element specification*
- **Media:** All gases that are compatible with the flow element material
- **Accuracy**
Flow:
Gas Specific Calibration: ±0.75% reading, ±0.5% full scale
SpectraCal™ Gas Equivalency: Typically ±4% reading, ±0.5% full scale; gas conditions specific to application will determine accuracy; *utilize FCI's online tool, AVAL, to evaluate your application and provide expected accuracy*
Temperature: ±2 °F [±1,1 °C] (display only, flow rate must be greater than 5 AFPS [1,5 m/sec])
- **Repeatability**
Flow: ±0.5% reading
Temperature: ±1 °F [±1 °C] (flow rate must be greater than 5 AFPS)
- **Temperature Coefficient**
With optional temperature compensation; valid from 10% to 100% of full scale calibration
Flow: Maximum ±0.015% of reading / °F up to 500 °F
[±0.03% of reading / °C up to 260 °C]
- **Turndown Ratio**
Standard: Factory set and field adjustable from 10:1 to 100:1 within calibrated flow range
- **Temperature Compensation**
Standard: ±30 °F [±16 °C]
Optional: ±100 °F [±55 °C]
- **Agency Approvals**
FM, FMC (Canadian): Class I, Division 1, Hazardous Locations;
Groups B,C,D,E,F,G
ATEX and IECEx: Zone 1, II 2 GD Ex d IIC T4
NEPSI, CPA, Inmetro, GOST-R, GOST-K pending
- **Calibration:** Performed on NIST traceable equipment

Flow Element

- **Material of Construction**
All-welded 316L stainless steel; Hastelloy-C optional
- **Operating Pressure**
Fixed Connection NPT: 1000 psig [69 bar (g)]
Fixed Connection Flanged: per flange rating
- **Operating Temperature (Process)**
-40 °F to 350 °F [-40 °C to 177 °C]
-40 °F to 500 °F [-40 °C to 260 °C]
- **Process Connection**
Retractable Packing Glands
Low pressure 50 psig [3,5 bar (g)] or medium pressure (500 psig [34 bar (g)]) with graphite or Teflon packing material; 1 1/4" male NPT or ANSI or DIN flange
Teflon packing required when process media is ozone, chlorine or bromine
Fixed Fittings: 1" male NPT or ANSI or DIN flange
Insertion Length: Field adjustable lengths
1" to 6" [25 mm to 152 mm]
1" to 12" [25 mm to 305 mm]
1" to 21" [25 mm to 533 mm]
1" to 60" [25 mm to 1524 mm]
Fixed lengths from 2.6" to 60" [66 mm to 1524 mm]
- **Remote Transmitter Configurations:** Transmitter may be mounted remotely from flow element using interconnecting cable (up to 1000' [300 m])

Flow Transmitter/Electronics

- **Operating Temperature:** 0 °F to 150 °F [-18 ° to 65 °C]
- **Input Power**
AC: 85 Vac to 265 Vac
DC: 24 Vdc ±20%
- **Outputs**
Analog
Standard: Three (3) 4-20 mA*, 0-1kHz, or 0-10 kHz pulse/frequency
4-20 mA outputs are user assignable to flow rate, temperature and/or if so equipped, pressure; outputs are user programmable to full flow range or subsets of full flow range; pulse/frequency output is user selectable as pulse for external counter/flow totalizer, or as 0-1 kHz or 0-10 kHz frequency representing flow rate
* *Outputs are isolated and have fault indication per NAMUR NE43 guidelines, user selectable for high (>21.0 mA) or low (<3.6 mA)*
Optional: Standard output plus two (2) 2A SPDT relays
Relays independently user assignable to flow, temperature or pressure; user programmable for hi/lo trip, hysteresis from 00.0 to 99.9 counts and time delay from 00.0 to 99.9 seconds
Digital
Standard: USB, Ethernet
Optional: HART (comes standard with analog outputs, V7 compliant)
FOUNDATION™ fieldbus H1, PROFIBUS PA or Modbus RS-485
- **Auxiliary Inputs**
Two 4-20 mA input channels; used for FCI administered special configurations to allow ST110 series to accept outputs from external devices such as gas analyzers, gas composition or pressure sensors
- **Enclosures**
Main Transmitter/Electronics:
NEMA 4X, IP67; polyester powder coated aluminum; 1 conduit port threaded as 1" NPT or M20x1.5; 5.40" x 4.82" [137.2 mm x 122 mm]
Local Enclosure (Remote Configuration):
NEMA 4X, IP67; polyester coated aluminum; 1 conduit port threaded as 1" NPT or M20x1.5; 5.40" x 4.82" [137.2 mm x 122 mm]
- **Data Logger**
User programmable for readings per time increment to a maximum of 1 reading/second; removable, circuit board-mountable 2GB micro-SD (secure digital) memory card supplied; stores approximately 21M readings in ASCII comma-separated format
- **Readout/Display and Optical Touch Buttons (Optional):**
 - Large 2" x 2" [50 mm x 50 mm] LCD; digital plus bar graph and engineering units
 - Digital displays of flow rate, total flow, temperature and pressure (with STP models); user selectable for engineering units
 - Analog bar graph of flow rate
 - Relay/alarm status indication
 - User programmable 17 alphanumeric character field associated with each calibration group
 - Set-Up & Service mode displays text and service codes
 - Backlighting – backlight activated by proximity motion detection, or user may set for always on
 - Four (4) optical touch buttons for user programming of instrument set-up and service interrogation
 - Optical touch button activation through front window – no need to open enclosure to access or activate
 - Display is electronically rotatable in 90° increments to optimize viewing angle*Note: If readout/display not ordered, all user set-up and service interrogation must be done via computer link to bus comm and/or USB port.*

Specifications at reference operating conditions of 70 °F, 14.7 psia [21.1 °C, 1.013bar(a)] and straight pipe run 20d upstream, 10d downstream
FCI is a continuous improvement company; specifications subject to change without notice

Model ST110 Single-Point Insertion Mass Flow Meter

Integral Configuration

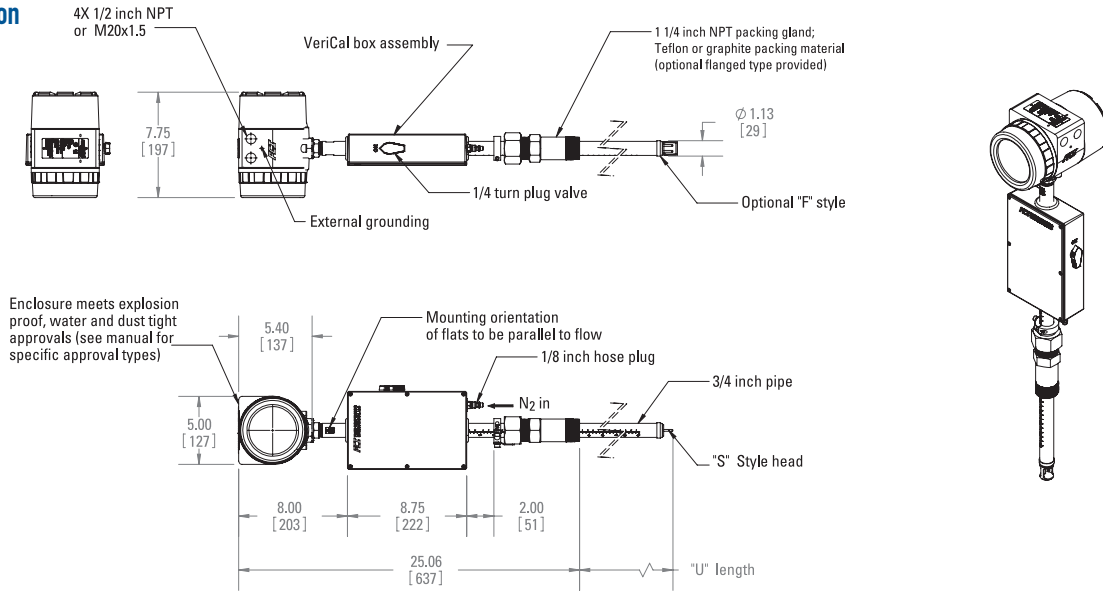

Remote Transmitter

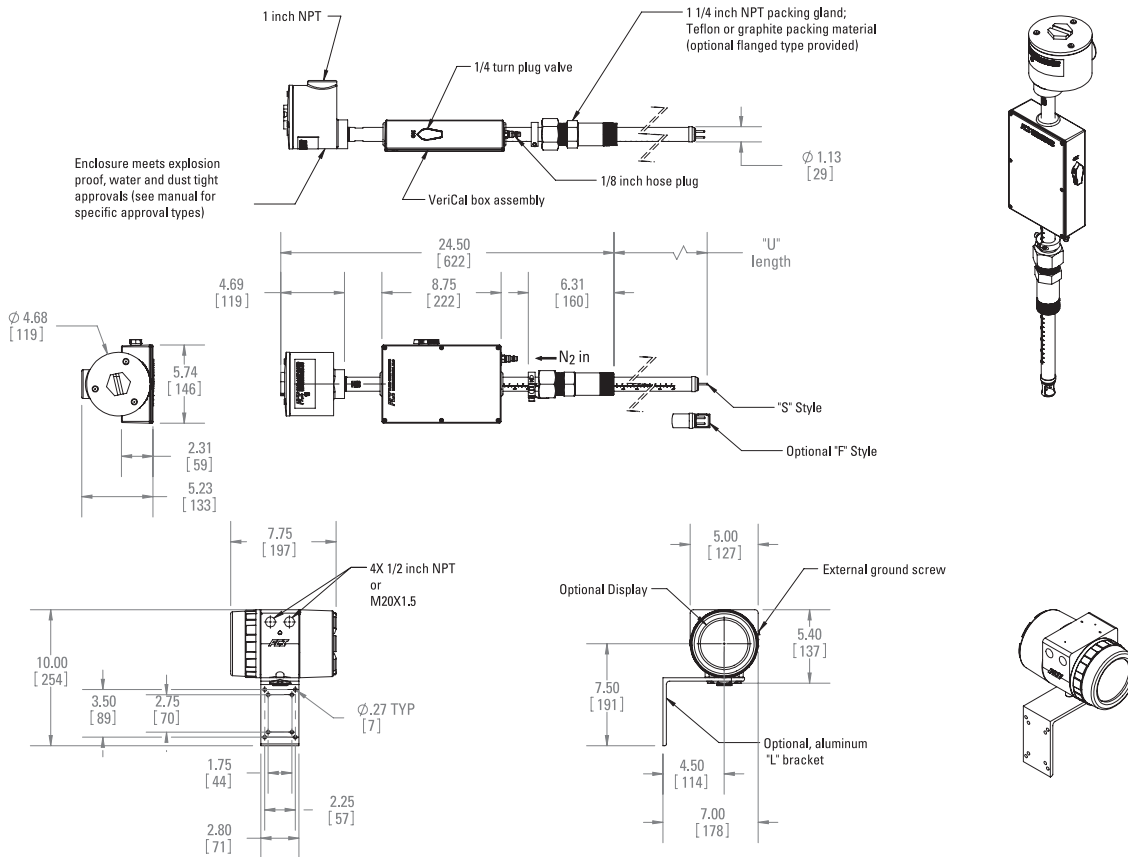

FCI FLUID COMPONENTS INTERNATIONAL LLC

Locally Represented By:

Visit FCI online at www.FluidComponents.com | FCI is ISO 9001:2000 and AS9100 Certified

FCI World Headquarters

1755 La Costa Meadows Drive | San Marcos, California 92078 USA | Phone: 760-744-6950 Toll Free (US): 800-854-1993 Fax: 760-736-6250

FCI Europe

Persephonestraat 3-01 | 5047 TT Tilburg, The Netherlands | Phone: 31-13-5159989 Fax: 31-13-5799036

FCI Measurement and Control Technology (Beijing) Co., LTD | www.fluidcomponents.cn

Room 107, Xianfeng Building II, No.7 Kaituo Road, Shangdi IT Industry Base, Haidian District | Beijing 100085, P. R. China
Phone: 86-10-82782381 Fax: 86-10-58851152

ST110 -

Flow Element (FE)
0

 -

Flow Transmitter (FT)
E

 -

Calibration
V
0

 -

General

Block No. 1 2 3 4 5 6 7 8 9 10 11 12 13 14 15 16 17 18 19

INSTRUCTIONS: To order an **ST110**, please fill in each numbered block above by selecting required codes from the corresponding categories below. Use of any "W" or "*" codes requires prior approval from FCI. For special data, documentation, test reports or required quality reports, refer to FCI's Engineering and Quality Assurance Order Information Sheets (OIS).

Flow Element			
Code [BLOCK 1] Flow Element: Temperature Service, Type and Materials of Construction			
350°F [177°C]	500°F [260°C]		
K	L	-FP style with VeriCal; 316L stainless steel	
W	W	Agency approved, customer specified	
*	*	Other, not agency approved	
Code (BLOCK 2)			
0 Block 2 Code is always "0"			
Code [BLOCK 3]		Code [BLOCKS 3-4]	
Process Connections			
Retractable Packing Gland, Low Pressure; 50 psig [3.5 bar(g)] ²			
P	0	1 1/4 inch, male NPT; graphite packing	
H	0	1 1/4 inch, male NPT; Teflon packing	
Q	Table A	Flange ⁵ ; graphite packing	
K	Table A	Flange ⁵ ; Teflon packing	
Retractable Packing Gland, Medium Pressure; 500 psig [34 bar(g)] ^{2,17}			
R	0	1 1/4 inch, male NPT; graphite packing	
L	0	1 1/4 inch, male NPT; Teflon packing	
T	Table A	Flange ⁵ ; graphite packing	
V	Table A	Flange ⁵ ; Teflon packing	
Fixed			
Y	0	1 inch, male NPT	
F	Table A	Flange	
Other or Special			
W	W	Agency approved, customer specified	
*	*	Other, not agency approved	
Code [BLOCK 5]		Code [BLOCKS 5-7]	
Insertion Length			
0	6	0	Variable length: 1 inch to 6 inch [25 mm to 152 mm]
1	2	0	Variable length: 1 inch to 12 inch [25 mm to 305 mm]
2	1	0	Variable length: 1 inch to 21 inch [25 mm to 533 mm]
3	6	0	Variable length: 1 inch to 36 inch [25 mm to 914 mm]
6	0	0	Variable length: 1 inch to 60 inch [25 mm to 1524 mm]
<input type="checkbox"/>	<input type="checkbox"/>	<input type="checkbox"/>	Fixed length (required if Code Y or F in Block 3) or custom variable length; specify req'd length to 0.1 inch E.g. 18 inches = 18.0, max. length is 99.9 inches

Code	[BLOCK 8] Pipe Mounting and Flow Direction
1	Horizontal, flow right-to-left or vertical up
2	Horizontal, flow left-to-right or vertical down

Transmitter and Electronics

Code	[BLOCK 9] Transmitter Mounting, Enclosure Material and Cable Entry Threading
1	Integral mount, aluminum; NPT cable entries ⁶
A	Integral mount, aluminum; metric cable entries ⁶
2	Remote mount, aluminum; NPT cable entries ⁶
B	Remote mount, aluminum; metric cable entries ⁶
3	Integral mount, stainless steel; NPT cable entries ⁶
C	Integral mount, stainless steel; metric cable entries ⁶
4	Remote mount, stainless steel; NPT cable entries ⁶
D	Remote mount, stainless steel; metric cable entries ⁶
W	Agency approved, customer specified
*	Other, not agency approved

(continued next page)

Table A – Flange [BLOCK 4]			
CS	316L SS	Hast C	Material
F	2	H	ANSI 1 1/2 inch 150 lb
K	B	J	ANSI 1 1/2 inch 300 lb
P	3	M	ANSI 2 inch 150 lb
R	L	N	ANSI 2 inch 300 lb
	V		DIN DN40 PN40
	6		DIN DN50 PN16
	Y		DIN DN50 PN40
	W		Agency appvd, custom spec'd

Notes

- Teflon packing material must be ordered when the process media is ozone, chlorine or bromine. *Contact FCI.*
- Transmitter enclosure has four (4) female conduit ports, NPT = 1/2", metric = M20x1.5. With remote mount the local enclosure's conduit port (attached to the flow element) varies by type of process connection and enclosure material specified:

Model	Process Connection	Aluminum		Stainless Steel	
		NPT	Metric	NPT	Metric
ST100, ST102A	Block 3 = C, D, G, M, N, J, F*	(2) 1/2"	(2) M20x1.5	(1) 1/2"	(1) M20x1.5
ST100, ST102A	Block 3 = P, H, Q, K, R, L, T, V, Y, F**	(1) 1/2"	(1) M20x1.5	(1) 1/2"	(1) M20x1.5
ST100L	Block 3 = Any	(2) 1/2"	(2) M20x1.5	(1) 1/2"	(1) M20x1.5
ST110, ST112A, and all STP	Block 3 = Any	(1) 1/2"	(1) M20x1.5	(1) 1/2"	(1) M20x1.5

* with 1" or DN25 flange

** with flange size larger than 1" or DN25

- Selection of medium pressure packing gland requires remote mount configuration. Block 9 must be Code 2, B, 4 or D.

(continued from previous page)

Code [BLOCK 10] Interconnecting Cable Length for Remote Configuration	
0	Not required <i>Specify with integral configurations, user supplied cable, or if cable ordered as separate line item from ST100 series accessories</i> ^{7,16}
A	10 feet [3 meters] PVC jacketed ⁸
B	25 feet [7,6 meters] PVC jacketed ⁸
C	50 feet [15 meters] PVC jacketed ⁸
D	100 feet [30 meters] PVC jacketed ⁸
1	10 feet [3 meters] Teflon jacketed ⁸
2	25 feet [7,6 meters] Teflon jacketed ⁸
3	50 feet [15 meters] Teflon jacketed ⁸
4	100 feet [30 meters] Teflon jacketed ⁸
W	Other
*	Non agency approved cable type or length other than above
Code [BLOCK 11] Transmitter Power Supply and Display	
A	24 Vdc power (19.2 Vdc to 28.8 Vdc); no digital display
B	24 Vdc power (19.2 Vdc to 28.8 Vdc); with display
C	85 Vac to 265 Vac power; no display
D	85 Vac to 265 Vac power; with digital display
Code [BLOCK 12] Transmitter Outputs and Communications	
1	(3) 4-20 mA outputs, one with HART; (1) frequency/pulse output
F	FOUNDATION™ fieldbus H1 ⁹
M	Modbus 485 ⁹
P	PROFIBUS-PA ⁹
W	Other
*	Other, not agency approved
Code [BLOCK 13]	
E	Always "E"

Calibration^{10, 11, 12}

Code [BLOCK 14] Calibration Application	
Standard Calibration: General Purpose	
A	Air: 1.25 SFPS to 125 SFPS; 10 psia to 65 psia; 40 °F to 100 °F [0,4 NMPS to 38 NMPS; 0,7 bar(a) to 3,5 bar(a); 4 °C to 38 °C]
D	Compressed air: 6 SFPS to 600 SFPS; 50 psia to 165 psia; 40 °F to 100 °F [1,8 NMPS to 183 NMPS; 3,5 bar(a) to 11 bar(a); 4 °C to 38 °C]
Custom Calibration: Calibration matched to user specified gas, flow range and conditions	
B	Air
C	Specific gas equivalency (digester gas, flue gas, etc.)
E	Nitrogen, helium, argon, CO ₂ , compressed air, digester gas
1	Natural gas (90% or greater methane content)
F	Hydrocarbons (methane, ethane, propane, etc.)
G	Hydrogen or hydrogen mixture
S	Flare gas, SR2x split-range, double calibration points, maximum 5% rdg accuracy <i>See specifications</i>
W ¹³	Agency approved, customer specified
Code [BLOCK 15] Calibrations, Setup and Conditions	
0	Standard
A	Extended temperature compensation
B	Extended range (> 100:1 turndown)
C	Vortab (VEL, VFK, VIS, VMR or VSR)
1	Vortab (VIP)
D	Flat velocity profile
E	Extended temperature compensation and extended range
F	Extended temperature compensation and Vortab (VEL, VFK, VIS, VMR or VSR)
2	Extended temperature compensation and Vortab (VIP)
G	Extended temperature compensation and flat velocity profile
H	Extended range and Vortab (VEL, VFK, VIS, VMR or VSR)
J	Extended range and flat velocity profile
3	Extended range and Vortab (VIP)
K	Extended temperature compensation, extended range and Vortab (VEL, VFK, VIS, VMR or VSR)
4	Extended temperature compensation, extended range and Vortab (VIP)
L	Extended temperature compensation, extended range and flat velocity profile

Code [BLOCKS 16-17] Second Calibration	
V 0	VeriCal calibration
Code [BLOCK 18] Additional Calibration Groups	
0	Not required
3	Three (3) calibration groups; two as specified in Blocks 14-17, plus one additional ¹⁴
4	Four (4) calibration groups; two as specified in Blocks 14-17, plus two additional ¹⁴
5	Five (5) calibration groups; two as specified in Blocks 14-17, plus three additional ¹⁴

General

Code [BLOCK 19] Agency Approval	
<i>CE Mark always included</i>	
0	Not required
1	FM, FMc
3	ATEX, IECEx ¹⁶
5	EAC / TR CU (Russia)
6	Inmetro
7	NEPSI
*	Other <i>Contact FCI for other approvals and conditions of use</i>

Notes

- Remote cable in an ST100 Series model is 8-conductor; remote cable in an STP100 Series model is 10-conductor. For user-supplied cable, overall shielded conductor type is required and wire resistance must be less than 8 Ohms.
- Cable suitable for conduit and some cable gland systems. For other cable gland system choices, see ST100 accessories list or contact FCI to supply separately. PVC cable maximum temperature 176 °F [80 °C]; Teflon cable maximum temperature 392 °F [200 °C].
- No analog, frequency/pulse, or other digital bus communications.
- FCI standard conditions are 14.7 psia [1,01 bar(a)] and 70 °F [21.1 °C].
- Calibration codes must be selected using FCI's proprietary AVAL application evaluation software.
- Transmitter setup, changes to factory supplied standard settings, verification or modification to calibration parameters or diagnostics requires external source communication with the transmitter.
- Customer specified calibration must not exceed temperature and pressure limitations of the ST100 Series product specifications.
- May specify up to three (3) additional calibrations for a total of five (5). Contact FCI for instructions on how to specify third, fourth and/or fifth calibration.
- ATEX/IECEx rated remote requires cable glands or conduit fittings which meet or exceed the installation area's required rating. When rated cable glands, armored cables and non-armored cable supplied are user supplied or selected from ST100 accessories list and ordered separately, enter Code 0 in Block 10.

Accessories

Part Number	Description
020849-03	VeriCal Kit Precision flow regulator, digital pressure gauge and interconnection hardware within NEMA 4 [IP66] rated enclosure; 25 foot [7,6 meter] quick-disconnect air hose
Sun Shield Kits Shades main transmitter, electronics, and/or display from direct sunlight; 316L stainless steel; attached directly to housing; kit includes shield, all hardware for attachment and instruction sheet	
023241-01	For use with integral mount transmitter
023237-01	For use with remote mount transmitter

Refer to separate *ST100 Series Accessories List* for a complete listing of all accessories such as cabling, ball valves, documentation test and QA documents and certificates, and spare parts.