

Model AS-FT

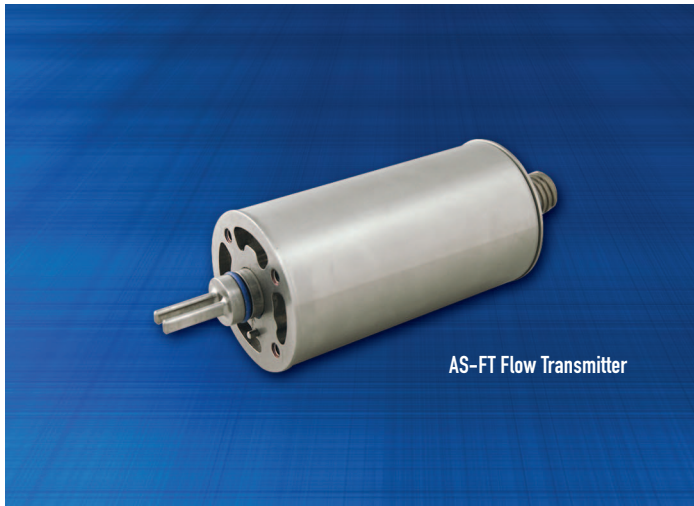

Aircraft Qualified Flow Sensor Series



FCI's Flow Sensor Applications

- Liquid Cooling Systems
- PACK Systems
- Bleed Air
- Fuel Transfer
- Lubricating Oils
- Hydraulic Fluids
- Ground and In-flight Refueling
- Flight Test Measurements
- Environmental Control Systems
- Air Management Systems

FCI's Flow Meters / Transmitters

FCI provides flow sensors for commercial and military aircraft applications with a unique combination of functions, features, and performance not available in other flow instrumentation. FCI's Thermal Dispersion Technology (TDT) directly measures mass flow of air, gases, water or liquids, which saves cost, installation space, and weight over alternatives that require the addition of pressure and temperature sensors, and a flow computer to infer mass flow. FCI flow sensors are also inherently dual-function, and temperature measurement of the fluid is readily available from the same sensor element. The flow meter system typically consists of a flow element that is inserted into the customer's process and a control unit that can be mounted integrally or remotely. The wetted portion of the probe is hermetically sealed, made of stainless steel parts joined by gas tungsten arc weld or nickel braze. The element construction provides excellent corrosion resistance that can withstand up to 2000 psig or more in line pressures. The insertion length is specified by the customer to position the thermowells in the center of the flow stream.

The electronics are mounted in an environmentally sealed enclosure with a gasket under the lid. Power input is 22-29 Vdc per MIL-STD-704. The electronics maintain a temperature difference between the two RTDs by providing a current to the heater adjacent to the active RTD. The electrical current to the heater is repeatable and proportional to the mass flow rate of the process fluid.

The relationship between the heater current and the flow rate is linearized by the electronics and converted to a 0-5 Vdc or 0-10 Vdc analog signal. Because the flow induced heat dissipation effect is a logarithmic function, FCI mass flow meters provide remarkably wide turndowns, exceptional low-flow sensitivity, repeatability of $\pm 1\%$ full scale and an accuracy of $\pm 2\%$ full scale maintained over a 100:1 turndown. Each flow meter is factory calibrated at FCI's on-site, NIST-traceable calibration laboratory to provide the greatest accuracy.

Thermal Dispersion Technology Advantages

- No Moving Parts
- Direct Mass Flow Measurement
- Simple Installation
- Switch or Transmitter Output
- Low Flow Sensitivity
- Wide Turndown Range [100:1 or more]
- Minimal Pressure Drop
- Simultaneous Flow and Temperature Indication
- Extreme Temperature, Pressure and Vibration Service
- High Reliability and Maintenance Free
- Corrosion, Abrasion and Fouling Resistant
- Low Weight Compact Design

FCI's Thermal Dispersion Technology Advantage

FCI flow sensors have established an unmatched record of superior performance and reliability in the toughest applications. FCI's unique Thermal Dispersion Technology (TDT) provides exceptional reliability and repeatability for monitoring flow rate in liquids and gases.

The sensing element contains two thermowell-protected Resistance Temperature Detectors (platinum RTDs). When the flow element is installed in the process, the reference RTD measures the temperature of the surrounding fluid, while the active RTD is heated by an adjacent heater to a temperature that is warmer than the surrounding fluid. The temperature difference between the two RTDs is held constant by the flow sensor electronics. Increased flow cools the heated RTD and the electronics respond by increasing power to the heater to maintain the temperature difference. Decreased flow results in the electronics reducing power to the heater to maintain the temperature difference.

This technology provides a repeatable mass flow rate indication in harsh application conditions without moving parts in the sensor.

The mass of the active RTD and heater is balanced on the reference RTD through the use of a passive mass equalizing element. This assures that the FCI flow sensor remains accurate even with abrupt process temperature changes.

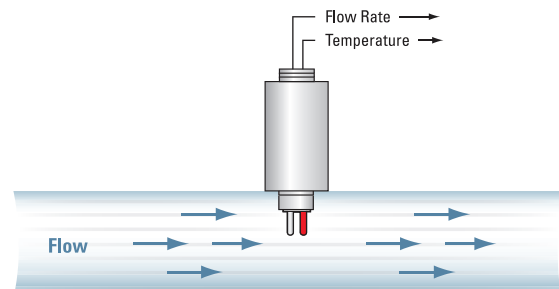

Model AS-FT Flow Transmitter Specifications

- **Service:** Flow measurement of liquids or gases
- **Material**
Probe: 316 SS with nickel braze per AMS 4777 or all welded construction; passivation finish per QQ-P-35; special alloys available
- **Process Connection:** Flanged
- **Insertion Length:** Per customer requirement
- **Signal Output**
Separate 0-5Vdc or 0-10 Vdc linearized analog outputs of flow and temperature; other outputs optionally available
- **Power Input:** 28 Vdc nominal per MIL-STD-704
- **Electrical Current Consumption:** 0.5 amp maximum
Power Consumption: 10 watt maximum
- **Weight:** 24 oz [680 g]
- **Proof Pressure:** Up to 2000 psig [138 bar (g)] or greater as required by application
- **Qualifications**
MIL-STD-810, MIL-STD-461
RTCA/DO-160
- **Flow Sensing Range:** As specified by customer; see table below

Flow Ranges

Process Fluid	Measurement Range
Air	0.25 SFPS to 1000 SFPS [0,07 NMPS to 305 NMPS]
Hydraulic Fluid, Fuel, Coolant	0.01 SFPS to 10 SFPS [0,003 MPS to 3 MPS]
Water, Ethylene Glycol (EGW)	0.01 SFPS to 5 SFPS [0,003 MPS to 1,5 MPS]

- **Temperature Range:**
Operating: -40 °F to 250 °F [-40 °C to 121 °C]
Optional (Remote Only)
High Temperature Flow Element: -65 °F to 850 °F [54 °C to 454 °C]
Remote Electronics: -40 °F to 250 °F [-40 °C to 121 °C]
Storage: -65 °F to 280 °F [54 °C to 138 °C]
- **Calibration**
Output calibrated to customer specified range in actual process media at FCI's NIST certified laboratory
- **Accuracy**
Flow: ±2 % of full scale; higher accuracy optionally available
Temperature: ±2 °F over the specified range
- **Repeatability**
Flow: ±1 % of full scale reading
Temperature: ±1 °F [±1 °C] over the specified range.
- **Response Time [Flow, 63% (1 Time Constant)]**
Air: 6 seconds
Liquid, + Flow to No Flow: 3 seconds
Liquid, No Flow to + Flow: 8 seconds
- **Flow Turndown Ratio:** Customer specified, up to 100:1
- **Options:** Calibration in custom piping

Model AS-FT Flow Transmitter Drawing

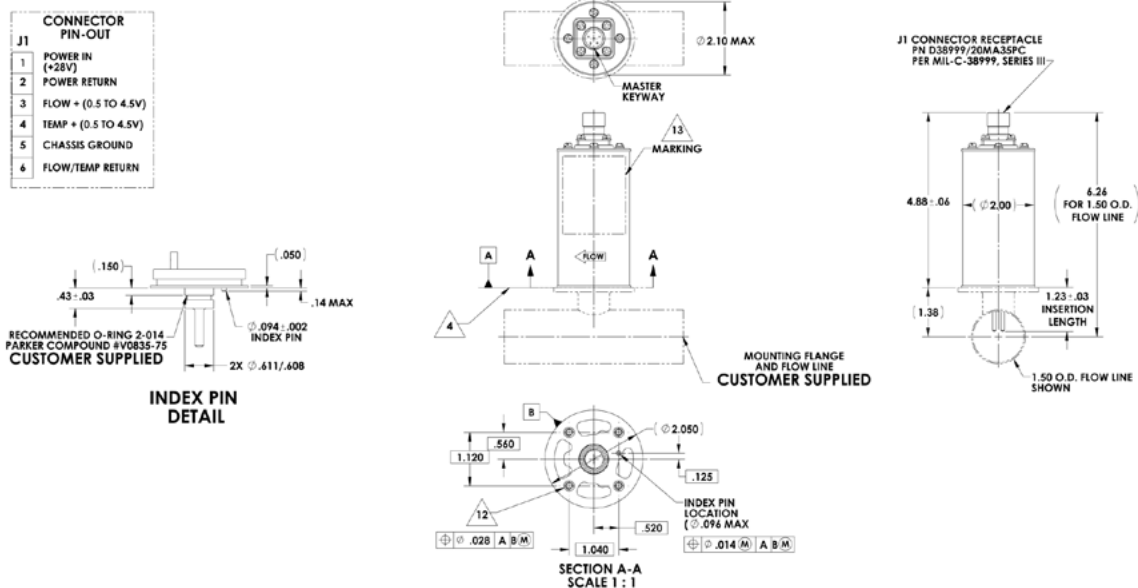

Locally Represented By:

Visit FCI online at www.FluidComponents.com | FCI is ISO 9001:2000 and AS9100 Certified

FCI World Headquarters

1755 La Costa Meadows Drive | San Marcos, California 92078 USA | Phone: 760-744-6950 Toll Free (US): 800-854-1993 Fax: 760-736-6250

FCI Europe

Persephonestraat 3-01 | 5047 TT Tilburg, The Netherlands | Phone: 31-13-5159989 Fax: 31-13-5799036

FCI Measurement and Control Technology (Beijing) Co., LTD | www.fluidcomponents.cn

Room 107, Xianfeng Building II, No.7 Kaituo Road, Shangdi IT Industry Base, Haidian District | Beijing 100085, P. R. China
Phone: 86-10-82782381 Fax: 86-10-58851152