

# STP102 Dual-Element Mass Flow Meter

## Thermal Dispersion Air/Gas Insertion Flow Meter with Pressure Measurement



The Model STP102 is the only dual-element insertion thermal dispersion gas mass flow meter available featuring pressure measurement to create a triple function solution (flow + temperature + pressure) in a single tap point insertion instrument—an industry first and FCI exclusive feature.

### Flow Element and Process Connections

- All welded construction
- 316L stainless steel
- Fast response and extra-rugged duty choices
- Variable (adjustable) and fixed insertion depths
- NPT, flanges, hot-tap retractable packing gland connections

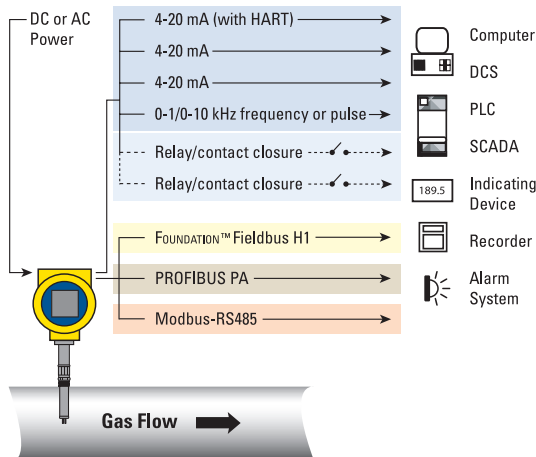

### Model STP102 Features

- Compatible with More than 200 Gases
- Direct Mass Flow Measurement
- Triple Function – Flow, Temperature and Pressure
- Temperature Service to 212 °F [100 °C]
- No Moving Parts, Non-Clogging
- Easy, Low Cost Single Point Insertion
- Best-In-Class Digital / Graphical Readout
- Multiple Analog Outputs
- Extensive Bus Communications Options
- Agency Approvals on Full Instrument
- On-Board Data Logger

### Discrete Mode

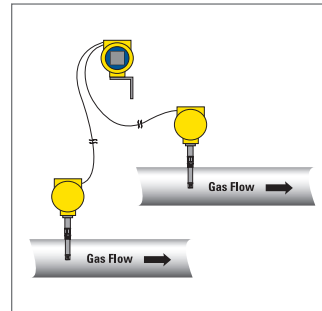

### Averaging System

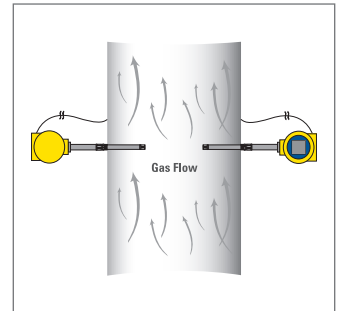

### Transmitter and Electronics

- All metal enclosure
- Four (4) conduit ports
- 2" x 2" [50 mm x 50 mm] backlit LCD readout/display
- Flow, total flow, temperature and pressure
- Triple analog outputs with HART
- FOUNDATION™ fieldbus, PROFIBUS PA, Modbus options
- Dual relays/alarms option
- Integral or remote mounting (up to 1000')
- AC or DC power
- Agency approvals for Division 1, Zone 1 hazardous locations
- Standard and extended range temperature compensation
- Data logging to removable micro-SD card

### Calibration

- Calibrated to your installation conditions and gas specifications on one of 18 precision, NIST traceable flow stands
- Up to five (5) unique calibrations stored onboard
- SpectraCal™ – 10 user selectable / changeable gases

# Model STP102 Features

## Dual flow elements

- Dual remotes or one integral plus one remote
- Averaging or discrete (independent) configurations

Four conduit ports provide greatest signal integrity and separation for power input, analog output lines, digital I/O, relays and/or auxiliary input signals; choice of NPT or M20 threads

## AC or DC power supply

Weather-proof, ruggedized, Ex rated enclosures

- Choices for local or remote mounting
- NEMA 4X, IP67

Global agency approvals of entire instrument system for hazardous location installations:

FM, FMc/CSA, ATEX, IEC Ex, Inmetro, CPA, NEPSI, GOST-R, GOST-K (pending)

Transmitter remote up to 1000' [300 m]

## Multiple calibrations

- Up to five independent, separate calibrations
- Multiple gases or mixed gas compositions
- Same gas, different flow range to optimize accuracy and extend turndown up to 1000:1

## Precision calibration and calibration choices

- Specific gas and application matched calibration in FCI NIST traceable facility
- Exclusive patented SpectraCal gas equivalency calibration with ten (10) user selectable gases

## Extensive selection of process connections

- Fixed connections
- ANSI or DIN flanges
- Retractable assemblies

## Stainless steel wetted parts

## Extensive analog and digital communications output choices

- Triple 4-20 mA with HART
- FOUNDATION™ fieldbus H1
- PROFIBUS PA
- Modbus RS-485
- 0-1 kHz or 0-10 kHz frequency or pulse
- Dual relays
- USB port
- Ethernet

## On-board data logger

Multi-function: measures mass flow rate and temperature

## Four (4) optical touch buttons

- Proximity activation, no need to open enclosure
- Full instrument programmability
- Protected against unwanted activation

## Comprehensive informational display

- Digital readout of all measured parameters; flow rate, total flow, temperature and pressure with engineering units
- Analog flow rate bar graph
- Alarm relay status indication
- Instrument fault indication
- User programmable 17 character field (example: display gas type, tag number or application/location)
- Display orientation rotates in 90° increments electronically
- Backlighted: auto-on activation via proximity sensor or set for always on

## Precision strain gauge pressure transducer

All welded sensor elements for maximum service life and leak-proofing

Precision, wide-ranging platinum RTD sensors

Exclusive equal mass sensors provide optimum performance in processes with wide temperature swings

Choice of two flow element styles to optimize application performance (-FP, -S)



— FP style



— S style

# Model STP102 Dual-Element Insertion Mass Flow Meter Specifications

## Instrument

- **Measuring Capability:** Flow rate, total flow, temperature and pressure
- **Basic Style:** Insertion, dual-element with pressure measurement
- **Flow Measurement Range:** 0.25 SFPS to 600 SFPS [0,07 NMPS to 172 NMPS]  
– Air at standard conditions; 70 °F and 14.7 psia [0 °C and 1013,25 bar (a)]
- **Temperature Measurement Range:** Commensurate with element;  
*see operating temperature in flow element specification*
- **Pressure Measurement Range**  
Available Ranges:  
0 psig to 50 psig [0 bar (g) to 3,4 bar (g)]  
0 psig to 160 psig [0 bar (g) to 11 bar (g)]  
0 psig to 500 psig [0 bar (g) to 34 bar (g)]  
0 psig to 1000 psig [0 bar (g) to 70 bar (g)]
- **Media:** All gases that are compatible with the flow element material
- **Accuracy**  
**Flow:**  
Gas Specific Calibration:  $\pm 0.75\%$  reading,  $\pm 0.5\%$  full scale  
SpectraCal™ Gas Equivalency: Typically  $\pm 4\%$  reading,  $\pm 0.5\%$  full scale; gas conditions specific to application will determine accuracy; *utilize FCI's online tool, AVAL, to evaluate your application and provide expected accuracy*  
**Temperature:**  $\pm 2^\circ\text{F}$  [ $\pm 1,1^\circ\text{C}$ ] (display only, flow rate must be greater than 5 AFPS [1,5 m/sec])  
**Pressure:**  $\leq \pm 1.0\%$  of span
- **Repeatability**  
**Flow:**  $\pm 0.5\%$  reading  
**Temperature:**  $\pm 1^\circ\text{F}$  [ $\pm 1^\circ\text{C}$ ] (flow rate must be greater than 5 AFPS)  
**Pressure:**  $\leq 0.1\%$  of span
- **Temperature Coefficient**  
*With optional temperature compensation; valid from 10% to 100% of full scale calibration*  
**Flow:** Maximum  $\pm 0.015\%$  of reading /  $^\circ\text{F}$  [ $\pm 0.03\%$  of reading /  $^\circ\text{C}$ ]
- **Turndown Ratio**  
**Standard:** Factory set and field adjustable from 10:1 to 100:1 within calibrated flow range
- **Temperature Compensation**  
**Standard:**  $\pm 30^\circ\text{F}$  [ $\pm 16^\circ\text{C}$ ]  
**Optional:**  $\pm 100^\circ\text{F}$  [ $\pm 55^\circ\text{C}$ ]
- **Agency Approvals**  
FM, FMc (Canadian): Class I, Division 1, Hazardous Locations;  
Groups B,C,D,E,F,G  
ATEX and IECEx: Zone 1, II 2 GD Ex d IIC T4  
NEPSI, CPA, Inmetro, GOST-R, GOST-K pending  
EX-rated pressure sensor:  
FM, CSA: Class I, Division 1, Groups A,B,C,D  
Dust ignition proof for Class II, Division 1, Groups E,F,G  
ATEX: 2 G Ex d C T4, Ex d IIC T5, Ex d IIC T6
- **Calibration:** Performed on NIST traceable equipment

## Flow Element

- **Material of Construction**  
All-welded 316L stainless steel
- **Operating Pressure** *limited by pressure sensor*  
**Fixed Connection NPT:** Per pressure sensor rating or 1000 psig [70 bar (g)], whichever is less  
**Fixed Connection Flanged:** Per pressure sensor rating or flange rating, whichever is less
- **Operating Temperature (Process)**  
Standard Pressure Sensor: 32 °F to 176 °F [0 °C to 80 °C]  
Ex Rated Pressure Sensor: -22 °F to 212 °F [-30 °C to 100 °C]
- **Process Connection**  
**Retractable Packing Glands**  
Low pressure 50 psig [3,5 bar (g)] or medium pressure (500 psig [34 bar (g)]) with graphite or Teflon packing material; 1 1/4" male NPT or ANSI or DIN flange  
*Teflon packing required when process media is ozone, chlorine or bromine*  
**Fixed Fittings:** 1" male NPT or ANSI or DIN flange  
**Insertion Length:** Field adjustable lengths  
1" to 6" [25 mm to 152 mm]  
1" to 12" [25 mm to 305 mm]  
1" to 21" [25 mm to 533 mm]  
1" to 60" [25 mm to 1524 mm]  
Fixed lengths from 2.6" to 60" [66 mm to 1524 mm]
- **Remote Transmitter Configurations:** Transmitter may be mounted remotely from flow element using interconnecting cable (up to 1000' [300 m]); remote mount required when medium pressure packing gland is required

## Pressure Sensor

### Standard Sensor

PSI	Bar	PSI	Bar	PSI	Bar	PSI	Bar
50	3,4	160	11	500	34	1000	70
100	7	290	20	1000	70	1740	120
250	17,24	500	34	2500	172	7975	550
Wetted Materials: Connection Pressure Sensor		316L PH 13-8 SS	316L 316L	316L 316L	316L 316L	316L 316L	316L 316L

### Ex Rated Sensor

PSI	Bar	PSI	Bar	PSI	Bar	PSI	Bar
50	3,4	160	11	500	34	1000	70
240	16,55	1160	80	1160	80	1740	120
290	20	1390	95,84	5800	400	7970	549,5
Wetted Materials: Connection Pressure Sensor		Stainless steel Stainless steel	Stainless steel Stainless steel	Stainless steel SS and Elgiloy	Stainless steel SS and Elgiloy	Stainless steel SS and Elgiloy	Stainless steel SS and Elgiloy

## Flow Transmitter/Electronics

- **Operating Temperature:** 0 °F to 130 °F [-18 ° to 54 °C]
  - **Input Power**  
**AC:** 85 Vac to 265 Vac  
**DC:** 24 Vdc  $\pm 20\%$
  - **Outputs**  
**Analogue**  
Standard: Three (3) 4-20 mA\*, 0-1kHz, or 0-10 kHz pulse/frequency  
4-20 mA outputs are user assignable to flow rate, temperature and/or if so equipped, pressure; outputs are user programmable to full flow range or subsets of full flow range; pulse/frequency output is user selectable as pulse for external counter/flow totalizer, or as 0-1 kHz or 0-10 kHz frequency representing flow rate  
\* *Outputs are isolated and have fault indication per NAMUR NE43 guidelines, user selectable for high (>21.0 mA) or low (<3.6 mA)*  
Optional: Standard output plus two (2) 2A SPDT relays  
Relays independently user assignable to flow, temperature or pressure; user programmable for hi/lo trip, hysteresis from 00.0 to 99.9 counts and time delay from 00.0 to 99.9 seconds
  - **Digital**  
Standard: USB, Ethernet  
Optional: HART (comes standard with analog outputs, V7 compliant)  
FOUNDATION™ fieldbus H1, PROFIBUS PA or Modbus RS-485
  - **Auxiliary Inputs**  
Two 4-20 mA input channels; used for FCI administered special configurations to allow STP102 series to accept outputs from external devices such as gas analyzers, gas composition or pressure sensors
  - **Enclosures**  
**Main Transmitter/Electronics:**  
NEMA 4X, IP67; polyester powder coated aluminum; 1 conduit port threaded as 1" NPT or M20x1.5; 5.40" x 4.82" [137.2 mm x 122 mm]  
**Local Enclosure (Remote Configuration):**  
NEMA 4X, IP67; polyester coated aluminum; 1 conduit port threaded as 1" NPT or M20x1.5; 5.40" x 4.82" [137.2 mm x 122 mm]
  - **Data Logger**  
User programmable for readings per time increment to a maximum of 1 reading/second; removable, circuit board-mountable 2GB micro-SD (secure digital) memory card supplied; stores approximately 21M readings in ASCII comma-separated format
  - **Readout/Display and Optical Touch Buttons (Optional):**
    - Large 2" x 2" [50 mm x 50 mm] LCD; digital plus bar graph and engineering units
    - Digital displays of flow rate, total flow, temperature and pressure (with STP models); user selectable for engineering units
    - Analog bar graph of flow rate
    - Relay/alarm status indication
    - User programmable 17 alphanumeric character field associated with each calibration group
    - Set-Up & Service mode displays text and service codes
    - Backlighting – backlight activated by proximity motion detection, or user may set for always on
    - Four (4) optical touch buttons for user programming of instrument set-up and service interrogation
    - Optical touch button activation through front window – no need to open enclosure to access or activate
    - Display is electronically rotatable in 90° increments to optimize viewing angle
- Note: If readout/display not ordered, all user set-up and service interrogation must be done via computer link to bus comm and/or USB port.*

Specifications at reference operating conditions of 70 °F, 14.7 psia [21.1 °C, 1.013 bar (a)] and straight pipe run 20d upstream, 10d downstream.  
FCI is a continuous improvement company; specifications subject to change without notice

# Model STP102 Dual-Element Insertion Mass Flow Meter

## Integral Configuration

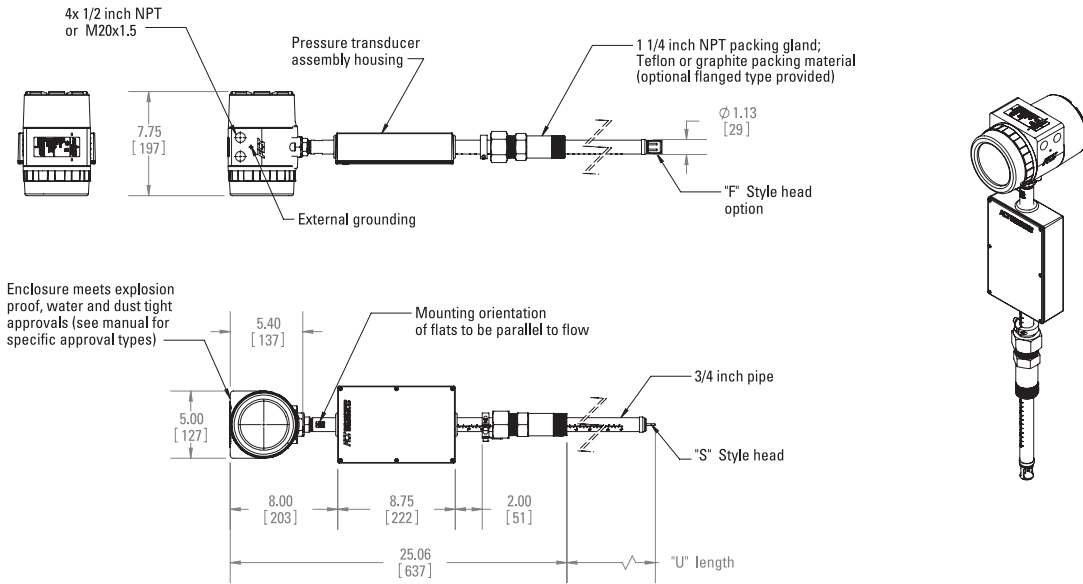

## Remote Transmitter

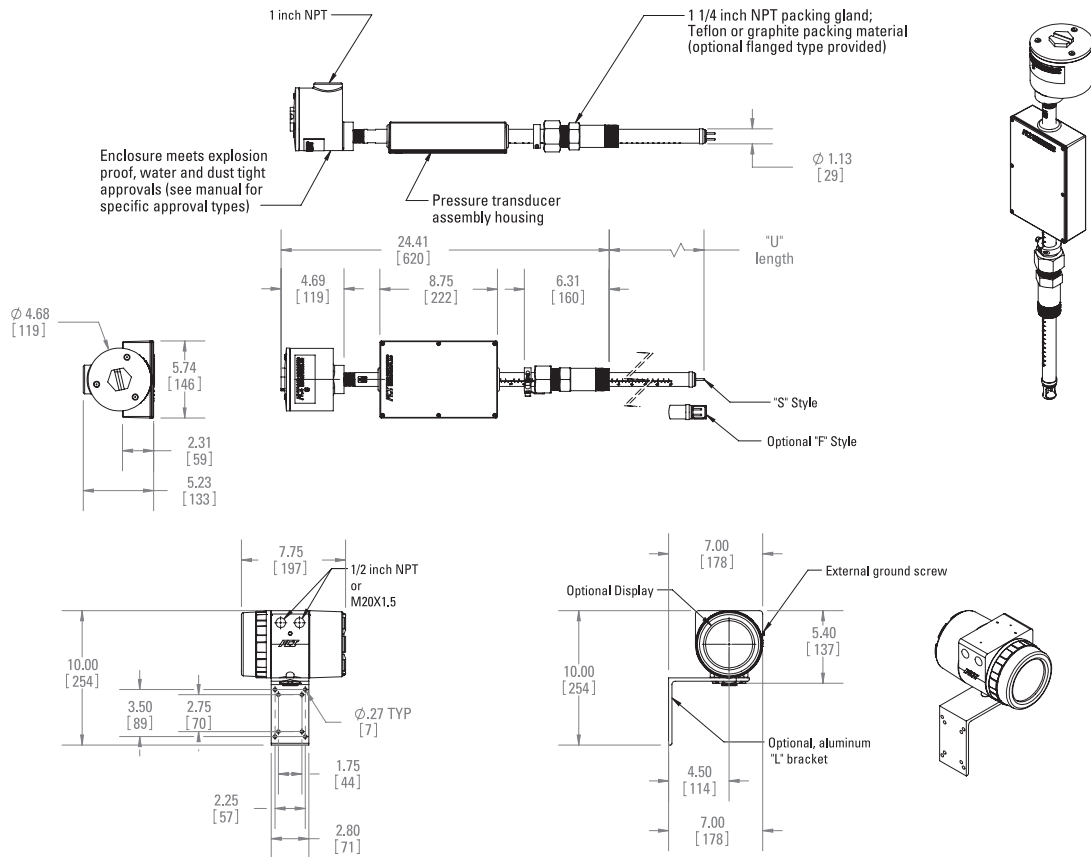

**FCI FLUID COMPONENTS INTERNATIONAL LLC**

Locally Represented By:

Visit FCI online at [www.FluidComponents.com](http://www.FluidComponents.com) | FCI is ISO 9001:2000 and AS9100 Certified

### FCI World Headquarters

1755 La Costa Meadows Drive | San Marcos, California 92078 USA | Phone: 760-744-6950 Toll Free (US): 800-854-1993 Fax: 760-736-6250

### FCI Europe

Persephonestraat 3-01 | 5047 TT Tilburg, The Netherlands | Phone: 31-13-5159989 Fax: 31-13-5799036

### FCI Measurement and Control Technology (Beijing) Co., LTD | [www.fluidcomponents.cn](http://www.fluidcomponents.cn)

Room 107, Xianfeng Building II, No.7 Kaituo Road, Shangdi IT Industry Base, Haidian District | Beijing 100085, P. R. China  
Phone: 86-10-82782381 Fax: 86-10-58851152

# STP102A

## Dual-Element Averaging Insertion Air/Gas Mass Flow and Pressure Meter

**STP102 A** - 

--	--	--	--	--	--	--	--

 - 

--	--	--	--	--	--	--	--	--	--	--	--	--	--	--	--	--	--	--

**E** - 

--	--	--	--	--	--	--	--	--	--	--	--	--	--	--	--	--	--	--	--

 - 

--	--	--	--	--	--	--	--	--	--	--	--	--	--	--	--	--	--	--	--

Block No.      1   2   3   4   5   6   7   8      9   10   11   12   13      14   15   16   17   18      19

**INSTRUCTIONS:** To order an **STP102A**, please fill in each numbered block above by selecting required codes from the corresponding categories below. Use of any "W" or "\*" codes requires prior approval from FCI. For special data, documentation, test reports or required quality reports, refer to FCI's Engineering and Quality Assurance Order Information Sheets (OIS).

Flow Element				
<b>Code [BLOCK 1] Flow Element: Type and Materials of Construction</b>				
<b>T</b> -FP style with pressure; 316L stainless steel				
<b>W</b> Agency approved, customer specified				
<b>*</b> Other, not agency approved				
<b>Code [BLOCK 2] Pressure Measurement: Range, Temperature Service and Materials of Construction</b>				
Standard Non-Ex Rated	Ex Rated	Range	Standard	Ex
1	5	0 psig to 50 psig [0 bar (g) to 3,447 bar (g)]	32°F to 176°F [0°C to 80°C]; PH 13-8 SS	-22°F to 212°F [-30°C to 100°C]; 316L
2	6	0 psig to 160 psig [0 bar (g) to 11,03 bar (g)]	32°F to 176°F [0°C to 80°C]; 316L	-22°F to 212°F [-30°C to 100°C]; 316L
3	7	0 psig to 500 psig [0 bar (g) to 34,47 bar (g)]	32°F to 176°F [0°C to 80°C]; 316L	-22°F to 212°F [-30°C to 100°C]; 316L and Elgiloy
4	8	0 psig to 1000 psig [0 bar (g) to 69,95 bar (g)]	32°F to 176°F [0°C to 80°C]; 316L	-22°F to 212°F [-30°C to 100°C]; 316L and Elgiloy
<b>W</b> Agency approved, customer specified				
<b>*</b> Other, not agency approved				
<b>Code [BLOCKS 3-4] Process Connections</b>				
<b>Code BLOCK 3</b>	<b>Code BLOCK 4</b>			
<b>Retractable Packing Gland, Low Pressure; 50 psig [3,5 bar (g)]<sup>2</sup></b>				
<b>P</b>	<b>0</b>	1 1/4 inch, male NPT;	graphite packing	
<b>H</b>	<b>0</b>	1 1/4 inch, male NPT;	Teflon packing	
<b>Q</b>	Table A	Flange <sup>5,15</sup> ;	graphite packing	
<b>K</b>	Table A	Flange <sup>5,15</sup> ;	Teflon packing	
<b>Retractable Packing Gland, Medium Pressure; 500 psig [34 bar (g)]<sup>2,17</sup></b>				
<b>R</b>	<b>0</b>	1 1/4 inch, male NPT;	graphite packing	
<b>L</b>	<b>0</b>	1 1/4 inch, male NPT;	Teflon packing	
<b>T</b>	Table A	Flange <sup>5,15</sup> ;	graphite packing	
<b>V</b>	Table A	Flange <sup>5,15</sup> ;	Teflon packing	
<b>Fixed</b>				
<b>Y</b>	<b>0</b>	1 inch, male NPT		
<b>F</b>	Table A	Flange <sup>15</sup>		
<b>Other or Special</b>				
<b>W</b> Agency approved, customer specified				
<b>*</b> Other, not agency approved				
<b>Code [BLOCKS 5-7] Insertion Length</b>				
<b>Code BLOCK 5</b>	<b>Code BLOCK 6</b>	<b>Code BLOCK 7</b>		
<b>0</b>	<b>6</b>	<b>0</b>	Variable length: 1 inch to 6 inch [25 mm to 152 mm]	
<b>1</b>	<b>2</b>	<b>0</b>	Variable length: 1 inch to 12 inch [25 mm to 305 mm]	
<b>2</b>	<b>1</b>	<b>0</b>	Variable length: 1 inch to 21 inch [25 mm to 533 mm]	
<b>3</b>	<b>6</b>	<b>0</b>	Variable length: 1 inch to 36 inch [25 mm to 914 mm]	
<b>6</b>	<b>0</b>	<b>0</b>	Variable length: 1 inch to 60 inch [25 mm to 1524 mm]	
<input type="checkbox"/>	<input type="checkbox"/>	<input checked="" type="checkbox"/>	Fixed length (required if Code Y or F in Block 3) or custom variable length; specify req'd length to 0.1 inch. <i>E.g. 18 inches = 18.0, max. length is 99.9 inches</i>	

Code	[BLOCK 8] Pipe Mounting and Flow Direction
<b>G</b>	Horizontal, element #1 right-to-left, element #2 left-to-right (opposite orientation) †
<b>H</b>	Horizontal, element #1 left-to-right, element #2 right-to-left (opposite orientation) †
<b>J</b>	Horizontal, both #1 and #2 elements left-to-right
<b>K</b>	Horizontal, both #1 and #2 elements right-to-left
<b>L</b>	Vertical up
<b>M</b>	Vertical down
<b>*</b>	Other, customer specified

† Note: If 'integral' is selected (Block 9, Codes 5 or E), element #1 is always the integral and element #2 the remote

**Transmitter and Electronics**

Code	[BLOCK 9] Transmitter Mounting, Enclosure Material and Cable Entry Threading
<b>5</b>	Transmitter integral with flow element #1, and flow element #2 is remote; aluminum, NPT cable entries
<b>E</b>	Transmitter integral with flow element #1, and flow element #2 is remote; aluminum, metric cable entries <sup>6</sup>
<b>6</b>	Transmitter remote from both flow elements; aluminum, NPT cable entries <sup>6</sup>
<b>F</b>	Transmitter remote from both flow elements; aluminum, metric cable entries <sup>6</sup>
<b>7</b>	Transmitter integral with flow element #1, and flow element #2 is remote; stainless steel, NPT cable entries <sup>6</sup>
<b>N</b>	Transmitter integral with flow element #1, and flow element #2 is remote; stainless steel, metric cable entries <sup>6</sup>
<b>8</b>	Transmitter remote from both flow elements; stainless steel, NPT cable entries <sup>6</sup>
<b>P</b>	Transmitter remote from both flow elements; stainless steel, metric cable entries <sup>6</sup>
<b>W</b>	Agency approved, customer specified
<b>*</b>	Other, not agency approved

(continued next page)

Table A – Flange [BLOCK 4]				
CS <sup>15</sup>	316L SS	Hast C	Material	
<b>F</b>	<b>2</b>	<b>H</b>	ANSI	1 1/2 inch 150 lb
<b>K</b>	<b>B</b>	<b>J</b>	ANSI	1 1/2 inch 300 lb
<b>P</b>	<b>3</b>	<b>M</b>	ANSI	2 inch 150 lb
<b>R</b>	<b>L</b>	<b>N</b>	ANSI	2 inch 300 lb
	<b>V</b>		DIN	DN40 PN40
	<b>6</b>		DIN	DN50 PN16
	<b>Y</b>		DIN	DN50 PN40
<b>W</b>			Agency appvd, custmr spec'd	

Notes
2. Teflon packing material must be ordered when the process media is ozone, chlorine or bromine. <i>Contact FCI.</i>
6. <i>See Notes, page 2</i>
15. Cannot select carbon steel flange when Hastelloy type flow element is selected in Block 1.
17. Selection of medium pressure packing gland requires remote mount configuration. Block 9 must be Code 6, F, 8 or P.

(continued from previous page)

Code [BLOCK 10] Interconnecting Cable Length for Remote Configuration	
0	Not required <i>Specify with user supplied cable or if cable ordered as separate line item</i> <sup>7,16</sup>
A	10 feet [3 meters] PVC jacketed <sup>8</sup>
B	25 feet [7,6 meters] PVC jacketed <sup>8</sup>
C	50 feet [15 meters] PVC jacketed <sup>8</sup>
D	100 feet [30 meters] PVC jacketed <sup>8</sup>
1	10 feet [3 meters] Teflon jacketed <sup>8</sup>
2	25 feet [7,6 meters] Teflon jacketed <sup>8</sup>
3	50 feet [15 meters] Teflon jacketed <sup>8</sup>
4	100 feet [30 meters] Teflon jacketed <sup>8</sup>
W	Agency approved, customer specified
*	Other, not agency approved

Code [BLOCK 11] Transmitter Power Supply and Display	
A	24 Vdc power (19.2 Vdc to 28.8 Vdc); no digital display
B	24 Vdc power (19.2 Vdc to 28.8 Vdc); with display
C	85 Vac to 265 Vac power; no display
D	85 Vac to 265 Vac power; with digital display

Code [BLOCK 12] Transmitter Outputs and Communications	
1	(3) 4-20 mA outputs, one with HART; (1) frequency/pulse output
F	FOUNDATION™ fieldbus H1 <sup>9</sup>
M	Modbus 485 <sup>9</sup>
P	PROFIBUS-PA <sup>9</sup>
0	Only for use ( <i>required</i> ) when configuring ST102E
W	Other
*	Other, not agency approved

Code [BLOCK 13]	
E	Always "E"

**Calibration**<sup>10, 11, 12</sup>

Code [BLOCK 14] Calibration Application	
T	Air; flat profile calibration
C	Air equivalency (digester gas, chlorine, flue gas, etc.)
E	Nitrogen, helium, argon, carbon dioxide or nitrous oxide
1	Natural gas (90% or greater methane content)
F	Hydrocarbons (methane, ethane, propane, etc.)
G	Hydrogen or hydrogen mixture
S	Flare gas, SR2x split-range, double calibration points, maximum 5% rdg accuracy <i>See specifications</i>
W <sup>13</sup>	Agency approved, customer specified

Code [BLOCK 15] Calibrations, Set-up and Conditions	
0	None
A	Extended temperature compensation
B	Extended range (> 100:1 turndown)
E	Extended temperature compensation and extended range

Code [BLOCKS 16-17] Second Calibration	
0 0	Not required
<input type="checkbox"/> <input type="checkbox"/>	Select from Codes shown in Blocks 14-15

Code [BLOCK 18] Additional Calibration Groups	
0	Not required
3	Three (3) calibration groups; two as specified in Blocks 14-17, plus one additional <sup>14</sup>
4	Four (4) calibration groups; two as specified in Blocks 14-17, plus two additional <sup>14</sup>
5	Five (5) calibration groups; two as specified in Blocks 14-17, plus three additional <sup>14</sup>

General	
Code [BLOCK 19] Agency Approval	
<i>CE Mark always included</i>	
0	Not required
1	FM, FMc <sup>20</sup>
3	ATEX, IECEx <sup>16,20</sup>
5	EAC / TR CU (Russia)
6	Inmetro
7	NEPSI
*	Other <i>Contact FCI for other approvals and conditions of use</i>

**Notes**

6. Transmitter enclosure has four (4) female conduit ports, NPT = 1/2", metric = M20x1.5. With remote mount, the local enclosure's conduit port (attached to the flow element) varies by type of process connection and enclosure material specified:

Model	Process Connection	Aluminum		Stainless Steel	
		NPT	Metric	NPT	Metric
ST100, ST102A	Block 3 = C, D, G, M, N, J, F*	(2) 1/2"	(2) M20x1.5	(1) 1/2"	(1) M20x1.5
ST100, ST102A	Block 3 = P, H, Q, K, R, L, T, V, Y, F**	(1) 1/2"	(1) M20x1.5	(1) 1/2"	(1) M20x1.5
ST100L	Block 3 = Any	(2) 1/2"	(2) M20x1.5	(1) 1/2"	(1) M20x1.5
ST110, ST112A, and all STP	Block 3 = Any	(1) 1/2"	(1) M20x1.5	(1) 1/2"	(1) M20x1.5

\* with 1" or DN25 flange

\*\* with flange size larger than 1" or DN25

7. Remote cable in an ST100 Series model is 8-conductor; remote cable in an STP100 Series model is 10-conductor. For user-supplied cable, overall shielded conductor type is required and wire resistance must be less than 8 Ohms.
8. Cable suitable for conduit and some cable gland systems. For other cable gland system choices, see ST100 accessories list or contact FCI to supply separately. PVC cable maximum temperature 176°F [80°C]; Teflon cable maximum temperature 392°F [200°C].
9. No analog, frequency/pulse, or other digital bus communications.
10. FCI standard conditions are 14.7 psia [1,01 bar(a)] and 70°F [21.1°C].
11. Calibration codes must be selected using FCI's proprietary AVAL application evaluation software.
12. Transmitter setup, changes to factory supplied standard settings, verification or modification to calibration parameters or diagnostics requires external source communication with the transmitter.
13. Customer specified calibration must not exceed temperature and pressure limitations of the ST100 Series product specifications.
14. May specify up to three (3) additional calibrations for a total of five (5). Contact FCI for instructions on how to specify third, fourth and/or fifth calibration.
16. ATEX/IECEx rated remote requires cable glands or conduit fittings which meet or exceed the installation area's required rating. When rated cable glands, armored cables and non-armored cable supplied are user supplied or selected from ST100 accessories list and ordered separately, enter Code 0 in Block 10.
20. Requires selection of Ex rated pressure sensor – Block 2 Code must be 5, 6, 7 or 8.

**Accessories**

Part Number	Description
<b>Sun Shield Kits</b> Shades main transmitter, electronics, and/or display from direct sunlight; 316L stainless steel; attached directly to housing; kit includes shield, all hardware for attachment and instruction sheet	
023241-01	For use with <b>integral</b> mount transmitter
023237-01	For use with <b>remote</b> mount transmitter

Refer to separate ST100 Series Accessories List for a complete listing of all accessories such as cabling, ball valves, documentation test and QA documents and certificates, and spare parts.