

Position Indicating Switches

For Hydraulic and Pneumatic Cylinders

aerospace
climate control
electromechanical
filtration
fluid & gas handling
hydraulics
pneumatics
process control
sealing & shielding



ENGINEERING YOUR SUCCESS.

Our New and Exclusive – **ALS Switch**

Position Sensing with a Magnetic Piston and Standard Steel Tube!

Tie rod mounted switch available in both PNP and NPN outputs –

See ALS Switch pages for details.

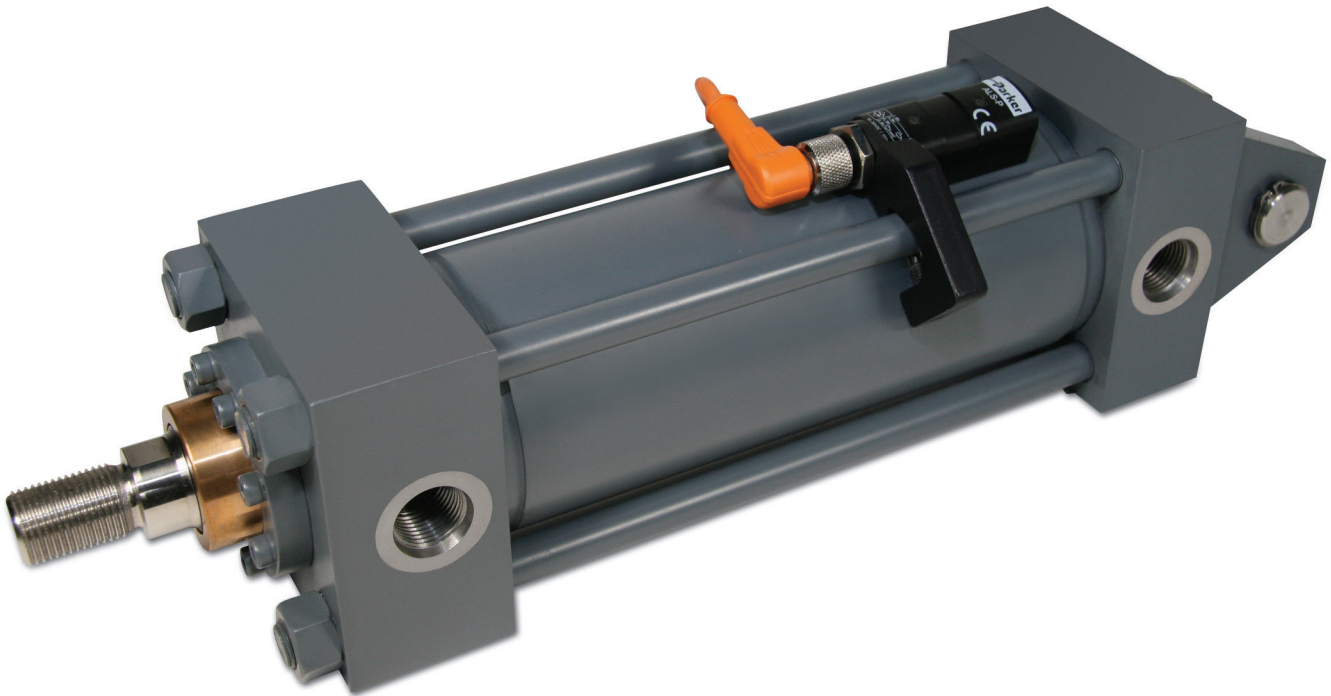

In line with our policy of continuing product improvement, specifications and information contained in this catalog are subject to change.

Copyright ©2009-2015 by Parker Hannifin Corporation.
All rights reserved.

PRINTED IN THE U.S.A.

WARNING

FAILURE OR IMPROPER SELECTION OR IMPROPER USE OF THE PRODUCTS AND/OR SYSTEMS DESCRIBED HEREIN OR RELATED ITEMS CAN CAUSE DEATH, PERSONAL INJURY AND PROPERTY DAMAGE.

This document and other information from the Parker Hannifin Corporation, its subsidiaries and authorized distributors provide product and/or system options for further investigation by users having expertise. It is important that you analyze all aspects of your application, including consequences of any failure and review the information concerning the product or system in the current product catalog. Due to the variety of operating conditions and applications for these products or systems, the user, through its own analysis and testing, is solely responsible for making the final selection of the products and systems and assuring that all performance, safety and warning requirements of the application are met.

The products described herein, including without limitation, product features, specifications, designs, availability and pricing, are subject to change by Parker Hannifin Corporation and its subsidiaries at any time without notice.

Offer of Sale

The items described in this document are hereby offered for sale by Parker Hannifin Corporation, its subsidiaries or its authorized distributors. This offer and its acceptance are governed by provisions stated on a separate page of the document entitled 'Offer of Sale'.

Table of Contents

.....

Description	Page
Switching Options	2
Value, Features and Benefits	3
Model Ordering Code / Specifications	4
Specifications	5
Wiring Connection	6
Part Numbers / Wiring Connection	7
Specifications / Wiring Connection	8
Reed Switches / Wiring Connection	9
Mounting Bracket / Cordsets	10
Dimensions	11-12
EPS 7 & 6 Sensors Inductive Proximity	11
CLS 1 & 4 Sensors Non-Contacting Magnetically Actuated	11
Connector Pin Numbering	11
Series and Parallel Wiring	11
Minimum Stroke	11
CLS-2 Threaded Style Switches	12
Switch Height – Series 2H, 3L & 2A	12
Operating Principle	12
Specifications – EPS Limit Switches	13
Specifications – CLS Limit Switches	14
How to Order EPS & CLS Limit Switches	15
Offer of Sale	16

Choose the style that's right for your needs –

Tie Rod Mounted Switches – actuated by a magnetic piston

- Can be positioned at any location along the cylinder to indicate end-of-stroke or mid-stroke locations.
- Allow multiple switches to be installed with numbers only restricted by available tie rod mounting space.
- Are non-intrusive and maintain pressure envelope integrity.
- Available for HV2 Series in 1.50" - 6.00" bores, JV and AV Series in 1.00" - 4.00" bores.

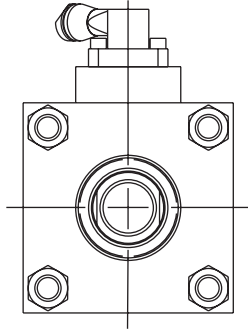

Head or Cap Mounted Switch

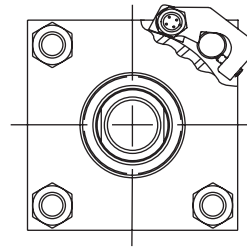

Tie Rod Mounted Switch

Tie rod mounted switches are lower profile than head and cap mounted styles.

ALS Switch –

Innovative sensor exclusive to Parker detects a magnetic piston through a **standard steel tube**. They are an economical alternative to Global Switches for long stroke applications that require a stainless steel tube.

Global Solid State and Reed Switches –

Require a non-ferrous tube; stainless steel material in HV2 and JV maintain standard envelope pressure rating; aluminum tube in JV offers economy with a reduction in envelope pressure rating (see Standard Specifications).

Head and Cap Mounted Switches

- Fixed mount design is actuated by proximity (without contact) of cushion sleeve or spear
- Provide an end-of-stroke signal with or without functional cushion
- Available up to 10.00" bore AV Series and 8.00" bore JV & HV2 Series

EPS Inductive Switches –

Are suitable for general industrial as well as automotive applications requiring weld field immunity.

CLS Magnetic Principal Switches –

Are contact type switches with no leakage current and are better suited for series wiring, higher load current requirements and have higher temperature resistance.

Switches mounted on our hydraulic cylinders add value to your machine design

- Switches and cylinder combine to form a compact package
- Tie rod switches are easily adjustable along cylinder stroke length
- Low profile switches are less prone to mechanical damage

Magnetic Piston option for 1.50"-6.00" bore HV2 Series and 1.00"-4.00" bore JV Series cylinders

- Non-intrusive design eliminates the possibility of oil leakage
- Non-ferrous tube material for conventional solid state and reed switches
- Standard carbon steel tube for the ALS Switch

HV2 and JV Series Cylinder – with Hi-Load style magnetic piston

Durable polyurethane bi-directional seal – for positive sealing with no by-pass and long life.

WearGard™ wear band – improves resistance to bearing loads and provides support for magnet.

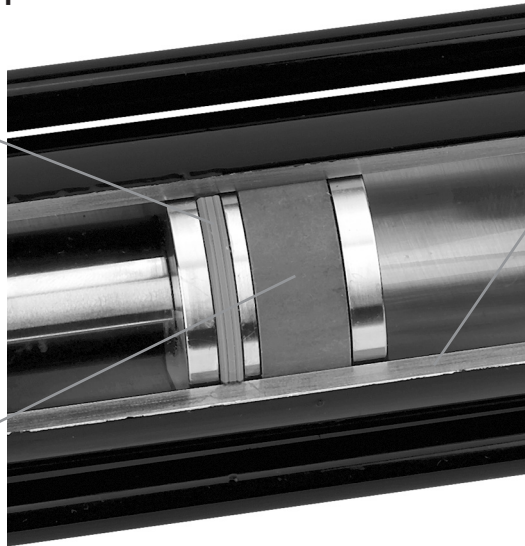

Cylinder Body – Standard carbon steel material for ALS Switch or 316 stainless steel for conventional solid state or reed switches. Aluminum¹ material available in JV Series.

¹Reduced pressure ratings apply for aluminum body in JV Series. See Standard Specifications page for ratings by bore size.

AV Series Cylinder – with Lipseal Magnetic Piston

Piston Lipseals – are self-compensating to conform to pressure and wear.

WearGard™ wear band – improves resistance to bearing loads and provides support for magnet.

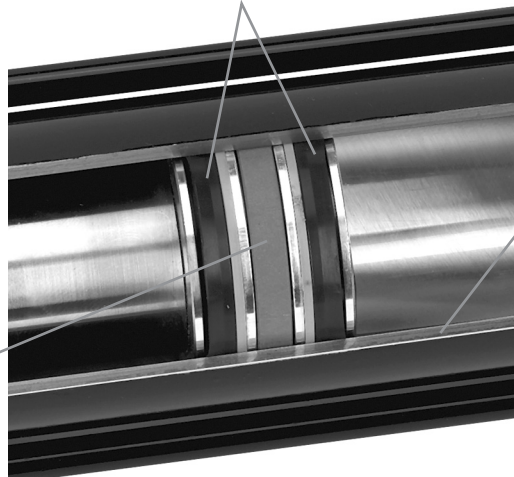

Cylinder Body – Standard steel material for ALS Switch or 316 stainless steel or aluminum for conventional solid state or reed switches.

How to Order a Miller Cylinder with a Magnetic Piston

Enter a '9' in the Modified field of the cylinder model code. Describe the modification in notes.

HV2 Series

For ALS Switches – 'Prepared for ALS Switches with magnetic piston and standard steel tube.'

For Global Switches – 'Prepared for global switches with magnetic piston and stainless steel tube.'

JV Series

For ALS Switches – 'Prepared for ALS Switches with magnetic piston and standard steel tube.'

For Global Switches and standard pressure rating – 'Prepared for global switches with magnetic piston and stainless steel tube.'

For Global Switches and reduced pressure rating (at lower cost) – 'Prepared for global switches with magnetic piston and aluminum tube.'

AV Series

For ALS Switches – 'Prepared for ALS Switches with magnetic piston and standard steel tube.'

For Global Switches – 'Prepared for global switches with magnetic piston and stainless steel tube.'

For Global Switches (at lower cost) – 'Prepared for global switches with magnetic piston and aluminum tube.'

Standard Specifications

- Bore diameters – 1.00" to 6.00" (See table below for Series, Bore, and Switch Type availability.)
- Strokes – up to 120" (Contact factory for longer strokes.)
- Piston rod diameters – 0.500" to 4.000"
- Temperature range – -10°F (-23°C) to +250°F (+121°C) (depending on seal class).
- Switch position may be restricted on model 89.
- Working pressure – series and tube material dependent
 - HV2** – 3000 psi with either carbon steel or stainless steel tube
 - JV** – 1000 psi nominal (dependent on bore size) with either carbon steel or stainless steel tube; reduced pressure with aluminum tube per table.
 - AV** – 250 psi regardless of tube material

Additional product specifications, application information and safety guidelines are available in Miller Industrial Cylinder Product catalogs.

Maximum Pressure Rating for JV Cylinder with Aluminum Tube

Bore Ø	Pressure Rating (psi) ¹
1.00	1900
1.50	1500
2.00	1100
2.50	950 ²
3.25	750
4.00	600

¹ When using Series L cylinders with aluminum bodies, do not introduce any shock or high inertia loading conditions. Pressure spikes must be avoided.

² Maximum pressure for aluminum tube in 2.50" bore with 0.625" rod is 700 psi.

Piston Magnet Availability by Series, Bore and Switch Type

Bore Ø	Available Switch Type		
	HV2	JV	AV
1.00 ³	None	Global	Global
1.50	Global & ALS	Global & ALS	Global & ALS
2.00	Global & ALS	Global & ALS	Global & ALS
2.50	Global & ALS	Global & ALS	Global & ALS
3.25	Global & ALS	Global & ALS	Global & ALS
4.00	Global & ALS	Global & ALS	Global & ALS
5.00	ALS	None	None
6.00	ALS	None	None

³ Global Reed Switch cannot sense end of stroke on 1.00" bore. When positioned up against the head or cap approx. 0.200" stroke-to-go results after switch provides output. Global Solid State switch stroke-to-go is approx. 0.030".

ALS Switch

- For magnetic piston sensing through steel tube material
- Cost effective alternative to stainless steel tube for longer strokes
- 4 wire DC connection

Switch Operation

The switch detects a change in polarity of the magnetic field as a piston with magnet moves through the cylinder.

Formatting

Before the switch is used for the first time, the piston with magnet should be run in and out of the cylinder to format the cylinder tube. The switch will detect the polarity of the residual magnetic field created by the movement of the magnetic piston during formatting.

Field Direction with Magnetic Piston

Single rod end cylinders are assembled with the piston magnet's North Pole facing the rod end. As the magnetic piston moves through the cylinder, it creates a stronger field opposite in polarity to the residual magnetism in the cylinder tube. As it moves under the switch, the change in polarity of the magnetic field in the cylinder tube is detected.

Switch Zone

Switch actuation occurs as the piston enters a switching 'zone'. The switching point is highly repeatable, in either direction, under conditions of constant piston speed and operating temperature.

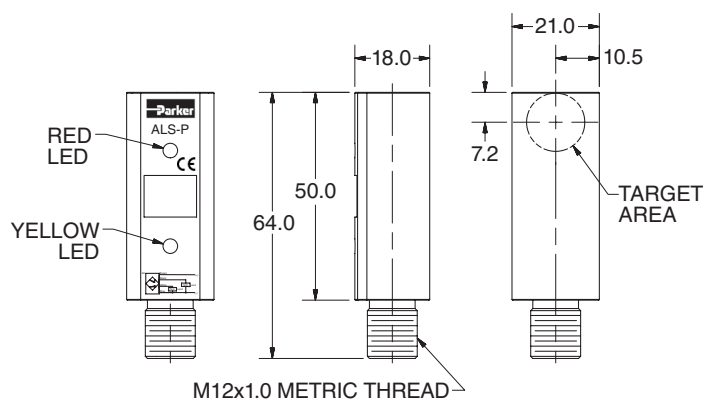

ALS Switch output states may be influenced by an external magnetic field. Care must be taken to avoid external magnetic field exposure.

- PNP and NPN versions can be wired N.O. or N.C.
- The ALS Switch is not designed for use with non-ferrous tubes

The switching zone may be up to 21mm wide depending on tube wall thickness and piston speed.

LED Indicators

There are two LED's (yellow and red) to indicate that the piston is inside or outside the switching zone. The sequence of the LED's is determined by the orientation of the north pole of the magnet system (rod end side of single rod end cylinders) to the connector.

When the ALS switch connector faces the rod side of single rod end cylinders the red LED turns ON when the piston is within the switching zone. The yellow LED is ON otherwise.

When the ALS switch connector faces the cap side of single rod end cylinders the yellow LED turns ON when the piston is within the switching zone. The red LED is ON otherwise.

Performance

Miller Fluid Power ALS Switches have been designed to operate at a maximum piston speed of 0.5m/s, and a maximum cylinder operating temperature of 85°C.

Specifications

Switching Output:	PNP or NPN
Hysteresis¹:	5mm
Repeatability¹:	0.5mm
Load Current:	100mA
Leakage Current:	≤ 10µA
Voltage Drop:	≤ 1.5 VDC
Short Circuit and Overload Protection:	Yes
Reverse Polarity Protection:	Yes
Supply Voltage:	10 - 30 VDC
LED(s):	Yes (2)
Current Consumption:	≤ 30 mA
Operating Temperature Range:	-25°C to +85°C (-13°F to +185°F)
Housing Material:	Black Polyamide (PA)
Enclosure Rating:	IP67

¹Hysteresis and repeatability based on measurements with a cylinder outer diameter of 46mm, wall thickness of 3mm and piston speed of 0.5m/s.

ALS Switch

Because the ALS switch detects change in polarity as the magnet moves through the cylinder, wiring connections are dependent on switch mounting orientation to the magnet's North Pole. The two possible orientations are:

- A – connector facing toward the rod end
(rod end 1 if K-type)
- B – connector facing toward the cap end
(rod end 2 if K-type)

Connections to Pin 1 (+VDC) and Pin 3 (-VDC) are the same for either switch orientation. But, as outlined in the table and wiring schematic diagrams below, the normal output state of Pins 2 & 4 flip between mounting orientations A & B. To sense the retracted position of the cylinder the cap end switch must be mounted in orientation A, and to sense the extended position of the cylinder the rod end switch must be mounted in orientation B. Note that ALS Switches allow a .38 - .50 inch stroke-to-go piston travel for end-of-stroke mounting locations.

Switch Orientations

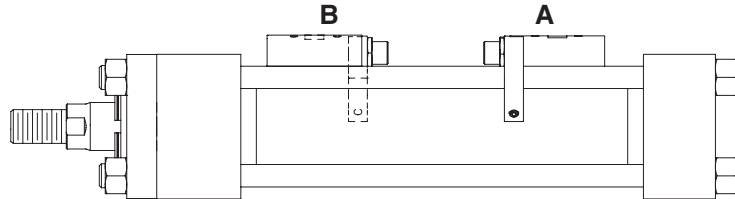

Example: An application requires that ALS switches sense the retract and extend positions of the cylinder with normally closed logic at both ends. How would the switches be wired?

Answer: The two switches would not be installed or wired the same way. The cap end switch would be installed in orientation A with Pin 1 (+VDC), Pin 2 (Load), Pin 3 (-VDC), Pin 4 (not used). The rod end switch would be installed in orientation B with Pin 1 (+VDC), Pin 2 (not used), Pin 3 (-VDC), Pin 4 (Load).

LED Function and Pin Wiring

Switch Mounting Orientation	Connector Facing Toward		LED indicator (on/off) when magnet is:				Pin	Wire	Function
	Single Rod Cylinder	Double Rod Cylinder	Out of Switch Zone		In Switch Zone				
			Red	Yellow	Red	Yellow			
A	Rod End	Rod End #1	off	on	on	off	1	Brown	+VDC
			2	White	N.C.				
			3	Blue	-VDC				
			4	Black	N.O.				
B	Cap End	Rod End #2	on	off	off	on	1	Brown	+VDC
			2	White	N.O.				
			3	Blue	-VDC				
			4	Black	N.C.				

PNP

Switch Orientation A

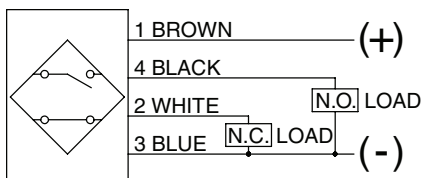

Switch Orientation B

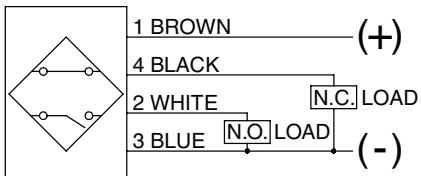

ALS Switch – Wiring Connection 12mm Connector

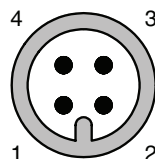

NPN

Switch Orientation A

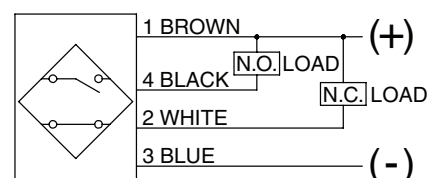

Switch Orientation B

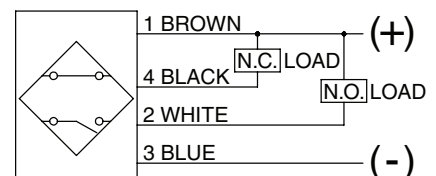

ALS Switch Part Numbers

All switches are packaged with tie rod mounting bracket and have a 4-pin male M12x1 threaded connector.

Part Number		Switch Bracket Usage
PNP	NPN	
ALS-PL	ALS-NL	JV & AV Series 1.00 – 4.00 Bore
ALS-PH	ALS-NH	HV2 Series 1.50 – 4.00 Bore
ALS-PHA	ALS-NHA	HV2 Series 5.00 – 6.00 Bore

Note: Specify piston code '7' in cylinder model number when using ALS Switches.

Minimum Stroke for ALS Switch

Bore Ø	JV & AV	HV2
1.50	3.13	3.00
2.00	3.13	3.00
2.50	3.13	2.88
3.25	3.13	2.75
4.00	3.13	2.63
5.00	N/A	2.38
6.00	N/A	2.19

ALS Switches allow a .38-.50 inch stroke-to-go piston travel for end-of-stroke mounting locations.

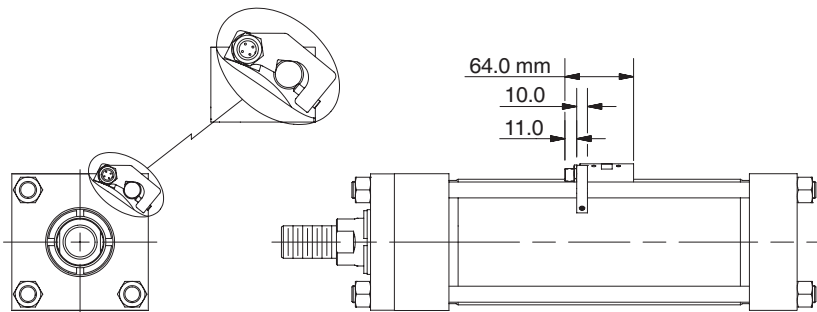

12mm Cordset for ALS Switches

12mm Cordset with Female Quick Connect

M12 Straight Connector	
Cable Length	Part Number
5 meters	9126487205
2 meters	9126487202

M12 Right Angle Connector	
Cable Length	Part Number
5 meters	9126487305
2 meters	9126487302

A female connector is available for all switches with the male 12mm quick connect option. The cordsets are available with a right angle or straight connector. Cordset part numbers are listed above.

Cordset Specifications

- Connector..... Polyvinylchloride (PVC) body material, PVC contact carrier, spacing to VDE 0110 Group C, (250VAC / 300VDC)
- Contacts..... Gold Plated Copper Tin (CuSn), stamped from stock.
- Coupling Method..... Threaded nut: Chrome plated brass.
- Cord Construction ... PVC non-wicking, non-hygroscopic, 250VAC / 300VDC. Cable end is stripped.
- Conductors..... Extra high flex stranding with PVC insulation
- Temperature..... -13°F to 158°F (-25°C to 70°C)
- Protection NEMA 1, 3, 4, 6P and IEC 1P67
- Cable Length..... 6.56 ft (2m) or 16.4 ft (5m)

Straight Connector

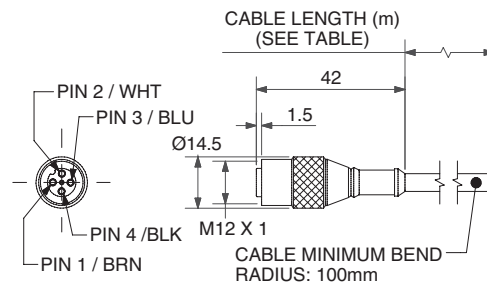

Right Angle Connector

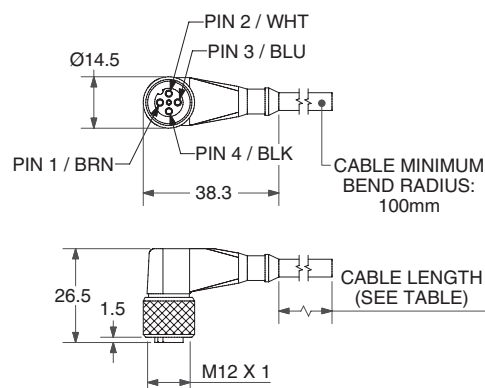

Global Drop-In Solid State Switches  



Wiring	PNP Switch	NPN Switch	PNP Switch ATEX Certified	PNP Switch High Temperature
3m Flying Leads	P8S-GPFAX	P8S-GNFAX	P8S-GPFLX/EX ¹	P8S-GPFLH ²
10m Flying Leads	P8S-GPFDX	P8S-GNFDX	N/A	N/A
0.3m Lead with 8mm Connector	P8S-GPCHX	P8S-GNCHX		

¹ ATEX switch is supplied with 2m Flying Leads. ² High Temperature switch is not UL Listed.

Specifications

Switch Classification	Standard PNP or NPN	ATEX Certified PNP	High Temperature PNP
Type	Electronic	Electronic	Electronic
Output Function	Normally Open	Normally Open	Normally Open
Switch Output	PNP/NPN	PNP	PNP
Operating Voltage	10 - 30VDC	18 - 30VDC	10 - 30VDC
Continuous Current	100 mA max.	70 mA max.	200 mA max.
Magnetic Field Sensitivity	2.65 - 2.95mT	2.65 - 2.95mT	25 Gauss
Switching Frequency	5 kHz	1 kHz	10 KHz
Power Consumption	10 mA max.	10 mA max.	15 mA max.
Voltage Drop	2.2 VDC max.	2.2 VDC max.	3.1 VDC max.
Ripple	10% of Operating Voltage	10% of Operating Voltage	15% of Operating Voltage
Hysteresis	1.5 mm max.	1.5 mm max.	1.5 mm max.
Repeatability	0.1 mm max.	0.1 mm max.	0.1 mm max.
EMC	EN 60 947-5-2	EN 60 947-5-2	EN 60 947-5-2
Short-circuit Protection	Yes	Yes	Yes
Power-up Pulse Suppression	Yes	Yes	Yes
Reverse Polarity Protection	Yes	Yes	Yes
Enclosure Rating	IP67	IP68	IP67
Shock and Vibration Stress	30g, 11 ms, 10 to 55Hz, 1 mm	30g, 11 ms, 10 to 55Hz, 1 mm	30g, 11 ms, 10 to 55Hz, 1 mm
Operating Temperature Range	-25°C to +75°C (-13°F to +167°F)	-20°C to +45°C (-4°F to +113°F)	-25°C to +105°C (-13°F to +221°F)
Housing Material	PA 12 Black	PA 12 Black	Aluminum
Connector Cable	PUR	PVC	PUR
Connector	PUR	-	-
Approval for ATEX	-	3D/3G	-

Global solid state switch outputs may be influenced by an external magnetic field. Care must be taken to avoid external magnetic field exposure.

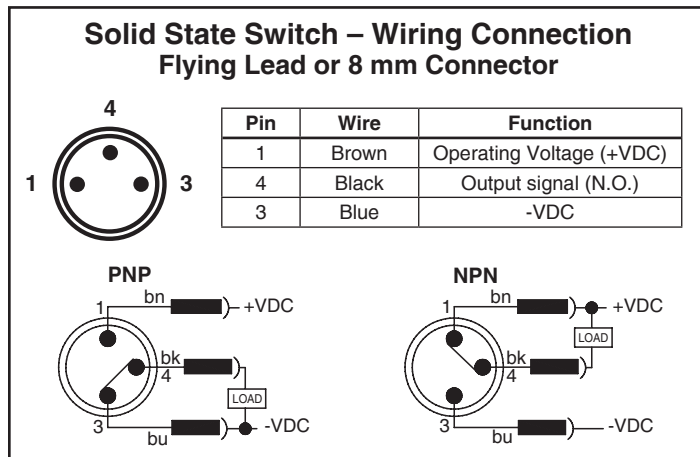

Global Drop-In Reed Switches  

Wiring	Reed Switch
3m Flying Leads	P8S-GRFAX
10m Flying Leads	P8S-GRFDX
0.3m Lead with 8mm Connector	P8S-GRCHX

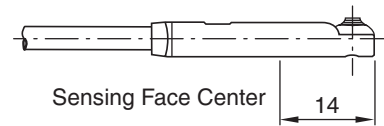
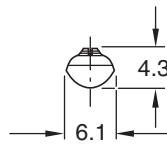

Specifications

- Type.....2-Wire Reed
- Output FunctionNormally Open
- Operating Voltage10 - 30 VDC
- Switching Power10 W
- Continuous Current.....100 mA max.
- Response Sensitivity2.1 - 3.4mT
- Switching Frequency400 Hz
- Voltage Drop2.2 V max.
- Ripple10% of Operating Voltage
- Hysteresis1.5 mm max.
- Repeatability0.2 mm max.
- EMCEN 60 947-5-2
- Reverse Polarity Protection.....Yes
- Enclosure Rating.....IP 67
- Shock and Vibration Stress.....30g, 11 ms, 10 to 55 Hz, 1 mm
- Operating Temperature Range.....-25°C to +75°C (-13°F to 167°F)
- Housing Material.....PA 12 Black
- Connector Cable.....PUR
- ConnectorPUR

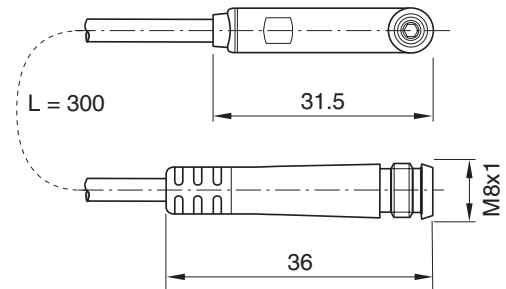

Global Reed Switch output may be influenced by external magnetic fields. Care must be taken to avoid external magnetic field exposure.

Reed Switch – Wiring Connection

Flying Lead or 8 mm Connector

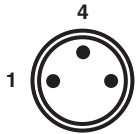

Pin	Wire	Function
1	Brown	Operating Voltage (+V)
4	Black	Not Used
3	Blue	Output Signal (-V or Ground)

Circuit for Switching Contact Protection (Inductive Loads)

(Required for proper operation 24V DC)

Put Diode parallel to loads following polarity as shown below.

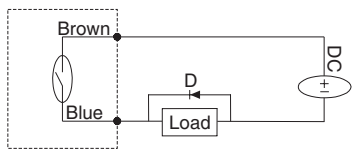

D: Diode: select a Diode with the breakdown voltage and current rating according to the load.

Typical Example—100 Volt, 1 Amp Diode
CR: Relay coil (under 0.5W coil rating)

(Recommended for longer life 120 VAC)

Put a resistor and capacitor in parallel with the load. Select the resistor and capacitor according to the load.

Typical Example:

- CR: Relay coil (under 2W coil rating)
- R: Resistor 1 KΩ - 5 KΩ, 1/4 W
- C: Capacitor 0.1 μF, 600 V

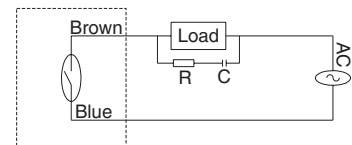

 Caution

- Use an ammeter to test reed switch current. Testing devices such as incandescent light bulbs may subject the reed sensor to high in-rush loads.
- **NOTE:** When checking an unpowered reed switch for continuity with a digital ohmmeter the resistance reading will change from infinity to a very large resistance (2 M ohm) when the sensor is activated. This is due to the presence of a diode in the reed switch.
- Anti-magnetic shielding is recommended for reed switches exposed to high external RF or magnetic fields.
- The magnetic field strength of the piston magnet is designed to operate with our switches. Other manufacturers' switches may not operate correctly in conjunction with these magnets.
- Use relay coils for reed switch contact protection.

- The operation of some 120 VAC PLC's (especially some older Allen-Bradley PLC's) can overload the reed switch. The switch may fail to release after the piston magnet has passed. This problem may be corrected by the placement of a 700 to 1K OHM resistor between the switch and the PLC input terminal. Consult the manufacturer of the PLC for appropriate circuit.
- Switches with long wire leads (greater than 15 feet) can cause capacitance build-up and sticking will result. Attach a resistor in series with the reed switches (the resistor should be installed as close as possible to the switches). The resistor should be selected such that R (ohms) > E/0.3.
- Global reed switch outputs may be influenced by an external magnetic field. Care must be taken to avoid external magnetic field exposure.

Tie Rod Bracket Assembly Part Number and Dimensions

Global switch bracket fits 1.00" - 4.00 bore cylinders. Global switches and bracket assemblies must be ordered separately.

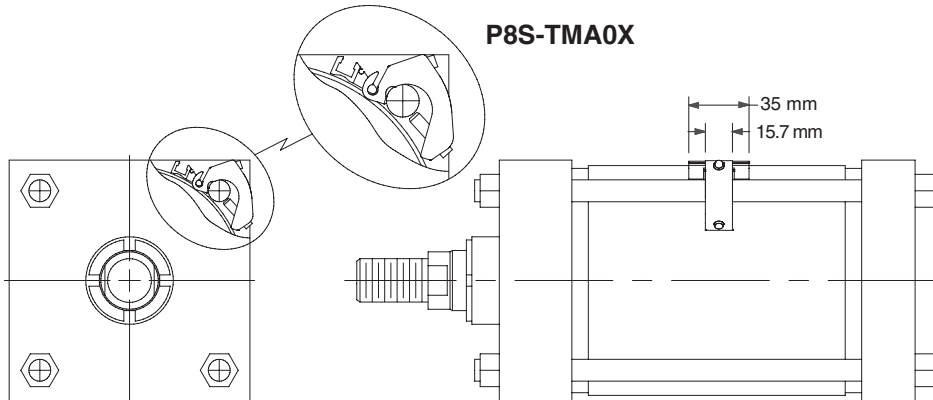

**Cordsets – 8mm Cordset for Global Switches
8mm Cordset with Female Quick Connect**

A female connector is available for all sensors with the male 8mm quick connect option. The male plug will accept a snap-on or threaded connector. Cordset part numbers are listed below.

Cable Length	Threaded Connector	Snap On Connector
5 meters	086620T005	086620S005
2 meters	086620T002	086620S002

Cordset Specifications

- Connector..... Oil resistant polyurethane body material, PA 6 (Nylon) contact carrier, spacings to VDE 0110 Group C, (150 AC/DC)
- Contacts Gold plated beryllium copper, machined from solid stock
- Coupling Method..... Snap-Lock or chrome plated brass nut
- Cord Construction .. Oil resistant black PUR jacket, non-wicking, non-hygroscopic, 300V. Cable end is stripped and tinned.
- Conductors..... Extra high flex stranding, PVC insulation
- Temperature..... -40 to 194°F (-40 to 90°C)
- Protection NEMA 1, 3, 4, 6P and IEC 1P67
- Cable Length..... 6.56 ft (2m) or 16.4 ft (5m)

Snap-On Straight Connector

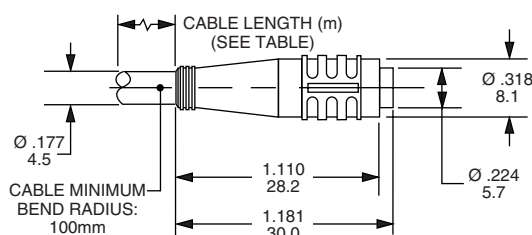

Threaded Straight Connector

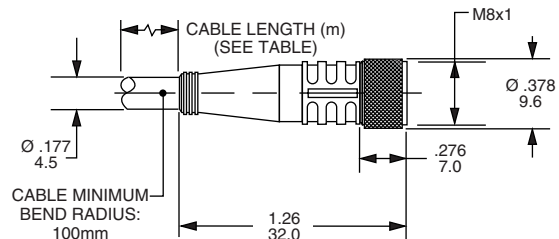

**EPS 7 & 6 Sensors
Inductive Proximity**

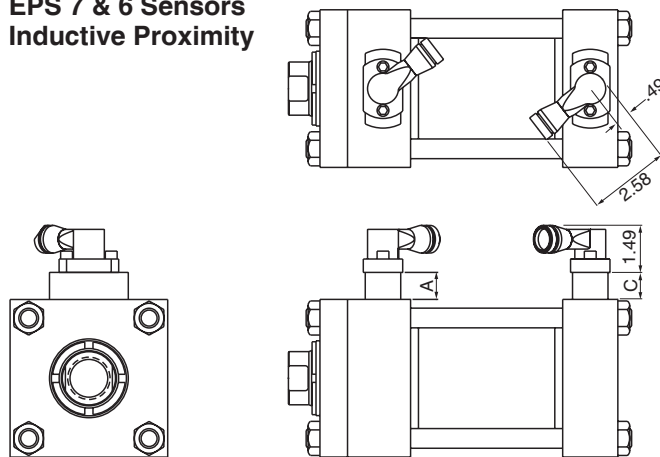

**CLS 1 & 4 Sensors
Non-Contacting
Magnetically
Actuated**

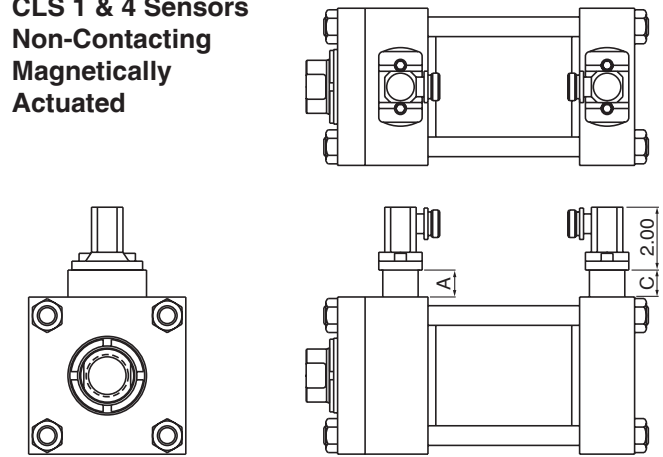

Series	A max.	C max.
HV2	.86"	1.75"
JV	1.55"	1.05"
AV	1.55"	1.30"
MHP	1.19"	1.05"

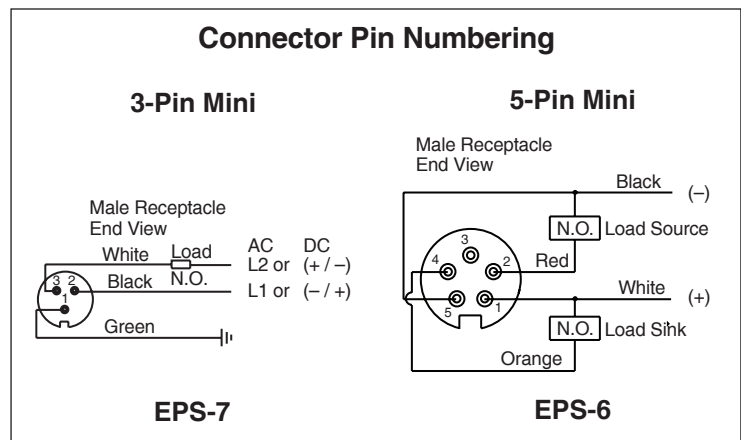

Series and Parallel Wiring

When Miller Fluid Power EPS-6 or 7 proximity switches are used as inputs to programmable controllers the preferred practice is to connect each switch to a separate input channel of the PLC. Series or parallel operations may then be accomplished by the internal PLC programming.

EPS-6 or 7 switches may be hard wired for series operation, but the voltage drop through the switches (see specifications) must not reduce the available voltage below what is needed to actuate the load.

EPS-6 or 7 switches may also be hard wired for parallel operation. However, the leakage current of each switch will pass through the load. The total of all leakage currents must not exceed the current required to actuate the load. When wiring EPS-6 sensors in parallel it is recommended that decoupling diodes be used.

Minimum Stroke

The minimum stroke for EPS-6 or 7 and CLS-1 or 4 sensors, utilizing standard components, is the cushion sleeve or spear length for the cylinder series in which the sensor is installed. See the individual Industrial Cylinder series catalog for cushion length details. Contact the factory if a shorter stroke is required.

CLS-2 Threaded Style Switches

Spacers are not required. Threaded switches can be adjusted for small changes to end of stroke position sensing.

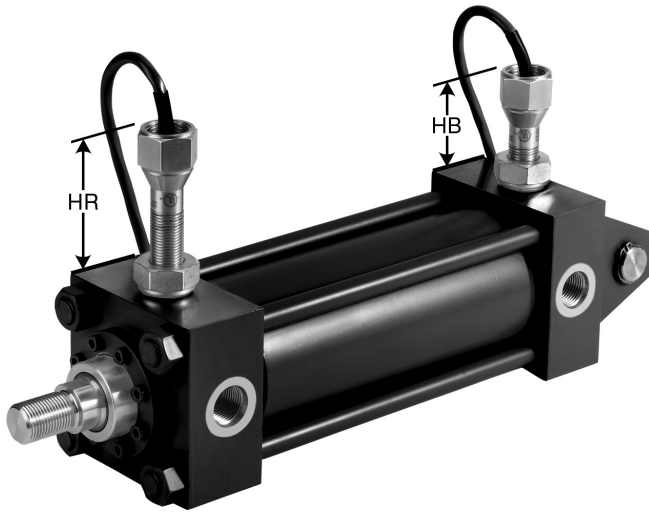

As shown in the illustrations below, these switches are magnetically operated. Dual magnets provide a dependable “snap action” for positive position sensing.

In the “Unoperated” position, the magnet assembly is attracted in the opposite direction of the arrow, causing a finely ground stainless steel connecting rod to hold the contacts open.

In the “Operated” position a ferrous part (cushion or piston) enters the sensing area and attracts the magnet assembly which causes the rod to draw the contacts together.

Switch Height – JV & AV Series

Bore Ø	HR Max.	HB Max	Bore	HR Max.	HB Max
1.50	3.00	2.63	5.00	2.81	1.94
2.00	2.94	2.38	6.00	3.44	3.06
2.50	2.94	2.13	7.00 ¹	3.44	2.56
3.25	3.19	2.81	8.00	3.38	2.06
4.00	3.13	2.44			

¹7.00 bore not available in JV Series

Switch Height – HV2 Series

Bore Ø	Rod Ø	HR	HB
1.50	0.625	2.56	3.31
	1.000	2.75	
2.00	1.000	2.56	3.25
	1.375	2.69	
2.50	1.000	2.31	2.94
	1.375	2.50	
	1.750	2.69	
3.25	1.375	2.94	2.56
	1.750	3.13	
	2.000	3.31	
4.00	1.750	2.88	2.44
	2.000	3.06	
	2.500	2.50	
5.00	2.000	2.31	2.31
	2.500	2.63	
	3.000	2.88	
	3.500	3.13	
6.00	2.500	2.13	3.00
	3.000	2.38	
	3.500	2.63	
	4.000	2.88	
7.00	3.000	3.38	2.69
	3.500	2.13	
	4.000	2.38	
	4.500	2.63	
	5.000	3.00	
8.00	3.500	3.13	2.25
	4.000	3.38	
	4.500	2.13	
	5.000	2.50	
	5.500	2.69	

Operating Principle

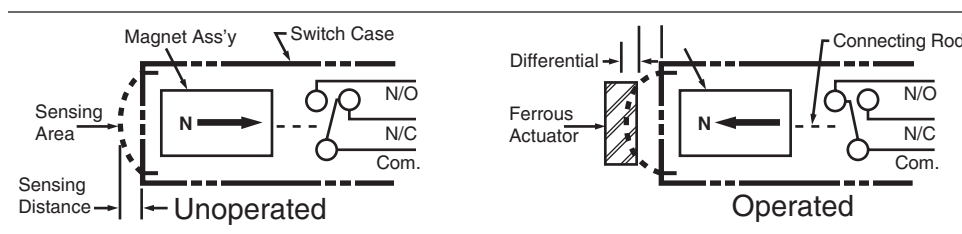

Sensing gap: .030" to .060"

Trip point: Factory set with piston bottomed out.

Release point: Approx. 0.25" piston travel.

Minimum cylinder stroke is .50" on 1.50" & 2.00" bores; and .75" on 2.50" bore and larger.

See the CLS Specification table for additional details.

Specifications – EPS Limit Switches

Switch Type:	Inductive Proximity	
Style:	EPS-7	EPS-6
Code Designator:	H	D
Description:	Economical, General Purpose, 2 wire device, primarily for AC applications. (Not suitable for 3 wire 24 volt Sinking or Sourcing applications.) Also for automotive industry applications.	Economical General Purpose, 3 wire, DC sensor, dual output: sinking and sourcing.
Supply Voltage:	20 to 250 VAC/DC	10 to 30 VDC
Load Current, min.:	8 mA	NA
Load Current, max.:	300 mA	200 mA
Leakage Current:	1.7 mA max.	10 micro amps max.
Voltage Drop:	7 V, max.	2 VDC max.
Operating Temperature:	-14° to +158° F	-14° to +158° F
Switch Type:	Inductive proximity	Inductive proximity
Part Number:	148897 _ _ _ _	148896 _ _ _ _
4 Digit Part Number Suffix:	Add 4-digit part number suffix to indicate probe length: 0125=1.25", 0206=2.06", 0288=2.875", 0456=4.562"	
Connection:	3 pin mini	5 pin mini
Enclosure Rating:	IEC IP67	IEC IP67
LED Indication:	Yes	Yes
Short Circuit Protection:	Yes	Yes
Weld Field Immunity:	Yes	Yes
Output:	2 wire, Normally Open with leakage current	Dual output: DC Sinking and DC Sourcing, user selectable via wiring
Approvals/Marks:	CE, UL, CSA	CE, UL, CSA
Make/Break Location:	0.13" from end of stroke, typical. Tolerance is +0/- .13"	
Wiring Instructions:	Pin 1: AC Ground (Green) Pin 2: Output (Black) Pin 3: AC Line (White)	Pin 1) +10 to 30 VDC (White) Pin 2) Sourcing Output (Red) Pin 3) Grounded (not connected or required) Pin 4) Sinking Output (Orange) Pin 5) DC Common (Black)
Standard Cable: 6'	0853550006	0859170006
Standard Cable: 12'	0853550012	0859170012
Cable: 6', Right Angle	0875470006	-

Specifications – CLS Limit Switches

Switch Type:	Non-Contacting Magnetically Actuated		
Style:	CLS-1	CLS-4	CLS-2
Code Designator:	F	B	G
Description:	For applications where the customer needs NC contacts, zero leakage, zero voltage drop, higher or lower load current than EPS-style.	For applications where the customer needs NC contacts, zero leakage, zero voltage drop, higher or lower load current than EPS-style.	For applications where the customer needs NC contacts, zero leakage, zero voltage drop, higher or lower load current than EPS style. Threaded style permits small adjustability of make/break location.
Supply Voltage:	24 to 240 VAC/DC	24 to 240 VAC/DC	24 to 240 VAC/DC
Load Current, min.:	NA	NA	NA
Load Current, max.:	4 AMPS @ 120 VAC 3 AMPS @ 24 VDC	4 AMPS @ 120 VAC 3 AMPS @ 24 VDC	4 AMPS @ 120 VAC 3 AMPS @ 24 VDC
Leakage Current:	None	None	None
Voltage Drop:	None	None	None
Operating Temperature:	-40° F to +221° F	-40° F to +400° F	-40° F to +221° F
Switch Type:	Non-contacting magnetically actuated	Non-contacting magnetically actuated	Non-contacting magnetically actuated
Part Number:	148275 _ _ _ _	149109 _ _ _ _	117000, 117017, 117034
4 Digit Part Number Suffix:	Add 4-digit part number suffix to indicate probe length: 0125=1.25", 0206=2.06", 0288=2.875", 0456=4.562"		Switch selection is application dependent – Contact Factory
Connection:	3 pin mini	144" PTFE Coated Flying Leads with 1/2" conduit hub	36" Potted-in PVC cable (most sizes also with 1/2" conduit hub)
Enclosure Rating:	NEMA 1, 2, 3, 4, 4X, 5, 6, 6P, 11, 12, 12K, 13	NEMA 1, 2, 3, 4, 4X, 5	NEMA 4, 4X, 6, 6P, 7, 9
LED Indication:	No	No	No
Short Circuit Protection:	No	No	No
Weld Field Immunity:	Yes	Yes	Yes
Output:	SPDT (Single Pole Double Throw), Normally Open/Normally Closed, Form C	SPDT (Single Pole Double Throw), Normally Open/Normally Closed, Form C	SPDT (Single Pole Double Throw), Normally Open/Normally Closed, Form C
Approvals/Marks:	UL or CSA†	UL or CSA†	UL or CSA†
Make/Break Location:	0.13" from end of stroke, typical. Tolerance is +0/- .13"		
Wiring Instructions:	Pin 1: Common (Green) Pin 2: Normally Closed (Black) Pin 3: Normally Open (White)	Common (Black) Normally Open (Blue) Normally Closed (Red)	Common (Black) Normally Open (Blue) Normally Closed (Red)
Standard Cable: 6'	0853550006	–	–
Standard Cable: 12'	0853550012	–	–
Cable: 6', Right Angle	0875470006	–	–

†CSA available upon request – consult factory

How to Specify EPS & CLS Switches

EPS & CLS proximity switches may be ordered on AV, JV and HV2 and MHP Series cylinders as follows:

- 1) Complete the basic model number
- 2) Place a "9" in the model number to denote switches and/or special features.
- 3) Mounting styles 61, 62, 67, 81 and 82 should be used with caution because of possible mounting interferences.
- 4) Special modifications to cylinders other than switches must have a written description.

- 5) Specify letter prefix "H" for EPS-7, "D" for EPS-6, "F" for CLS-1, "B" for CLS-4, or "G" for CLS-2, then fill in the four blanks specifying port location, switch orientation and actuation point for both head and cap. If only one switch is used, place "XXXX" in the unused blanks.

Example = H13AGG-XXXX denotes a switch on the head end only, EPS-7

Example = XXXX-B42AGG denotes a switch on the cap end only, CLS-4

Head End

H	1	3	A	GG
Specify: "H" = EPS-7 "D" = EPS-6 "F" = CLS-1 ¹ "B" = CLS-4 ¹ "N" = Prep for EPS-6 and EPS-7 switches "P" = Prep for CLS-1 and CLS-4 switches "T" = Prep for CLS-2 switch	Port Location See Figure 1.	Switch Location See Figure 1.	Switch Orientation See Figure 2 for CLS-1, CLS-4, EPS-6 and EPS-7 only.	Actuation Point GG = End of Stroke FF = Stroke to Go; See Bulletins 0840-G-E1, 2 or 3 for stroke remaining.

Cap End

H	4	2	A	GG
Specify: "H" = EPS-7 "D" = EPS-6 "F" = CLS-1 ¹ "B" = CLS-4 ¹ "N" = Prep for EPS-6 and EPS-7 switches "P" = Prep for CLS-1 and CLS-4 switches "T" = Prep for CLS-2 switch	Port Location See Figure 1.	Switch Location See Figure 1.	Switch Orientation See Figure 2 for CLS-1, CLS-4, EPS-6 and EPS-7 only.	Actuation Point GG = End of Stroke FF = Stroke to Go; See Bulletins 0840-G-E1, 2 or 3 for stroke remaining.

Note: All specified switch and port locations are as seen from rod end of cylinder.

¹CLS-1 and CLS-4 proximity switches are not available on the head end of 1.50" bore with 1.00" rod and 2.00" bore with 1.375" rod

Figure 1

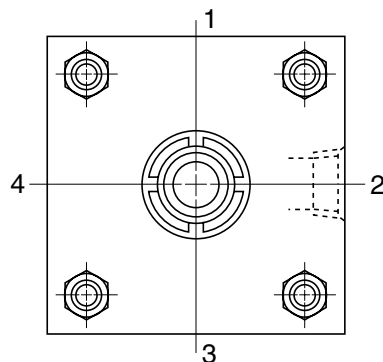
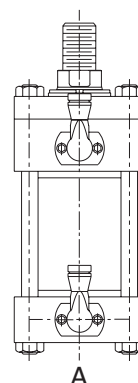

Figure 2



Offer of Sale

The items described in this document and other documents and descriptions provided by Parker Hannifin Corporation, its subsidiaries and its authorized distributors ("Seller") are hereby offered for sale at prices to be established by Seller. This offer and its acceptance by any customer ("Buyer") shall be governed by all of the following Terms and Conditions. Buyer's order for any item described in its document, when communicated to Seller verbally, or in writing, shall constitute acceptance of this offer. All goods, services or work described will be referred to as "Products".

1. Terms and Conditions. Seller's willingness to offer Products, or accept an order for Products, to or from Buyer is subject to these Terms and Conditions or any newer version of the terms and conditions found on-line at www.parker.com/saleterms/. Seller objects to any contrary or additional terms or conditions of Buyer's order or any other document issued by Buyer.

2. Price Adjustments; Payments. Prices stated on Seller's quote or other documentation offered by Seller are valid for 30 days, and do not include any sales, use, or other taxes unless specifically stated. Unless otherwise specified by Seller, all prices are F.C.A. Seller's facility (INCOTERMS 2010). Payment is subject to credit approval and is due 30 days from the date of invoice or such other term as required by Seller's Credit Department, after which Buyer shall pay interest on any unpaid invoices at the rate of 1.5% per month or the maximum allowable rate under applicable law.

3. Delivery Dates; Title and Risk; Shipment. All delivery dates are approximate and Seller shall not be responsible for any damages resulting from any delay. Regardless of the manner of shipment, title to any products and risk of loss or damage shall pass to Buyer upon placement of the products with the shipment carrier at Seller's facility. Unless otherwise stated, Seller may exercise its judgment in choosing the carrier and means of delivery. No deferral of shipment at Buyers' request beyond the respective dates indicated will be made except on terms that will indemnify, defend and hold Seller harmless against all loss and additional expense. Buyer shall be responsible for any additional shipping charges incurred by Seller due to Buyer's acts or omissions.

4. Warranty. Seller warrants that the Products sold hereunder shall be free from defects in material or workmanship for a period of eighteen months from the date of delivery to Buyer. The prices charged for Seller's products are based upon the exclusive limited warranty stated above, and upon the following disclaimer: **DISCLAIMER OF WARRANTY: THIS WARRANTY COMPRISES THE SOLE AND ENTIRE WARRANTY PERTAINING TO PRODUCTS PROVIDED HEREUNDER. SELLER DISCLAIMS ALL OTHER WARRANTIES, EXPRESS AND IMPLIED, INCLUDING DESIGN, MERCHANTABILITY AND FITNESS FOR A PARTICULAR PURPOSE.**

5. Claims; Commencement of Actions. Buyer shall promptly inspect all Products upon delivery. No claims for shortages will be allowed unless reported to the Seller within 10 days of delivery. No other claims against Seller will be allowed unless asserted in writing within 30 days after delivery. Buyer shall notify Seller of any alleged breach of warranty within 30 days after the date the defect is or should have been discovered by Buyer. Any action based upon breach of this agreement or upon any other claim arising out of this sale (other than an action by Seller for an amount due on any invoice) must be commenced within 12 months from the date of the breach without regard to the date breach is discovered.

6. LIMITATION OF LIABILITY. UPON NOTIFICATION, SELLER WILL, AT ITS OPTION, REPAIR OR REPLACE A DEFECTIVE PRODUCT, OR REFUND THE PURCHASE PRICE. **IN NO EVENT SHALL SELLER BE LIABLE TO BUYER FOR ANY SPECIAL, INDIRECT, INCIDENTAL OR CONSEQUENTIAL DAMAGES ARISING OUT OF, OR AS THE RESULT OF, THE SALE, DELIVERY, NON-DELIVERY, SERVICING, USE OR LOSS OF USE OF THE PRODUCTS OR ANY PART THEREOF, OR FOR ANY CHARGES OR EXPENSES OF ANY NATURE INCURRED WITHOUT SELLER'S WRITTEN CONSENT, EVEN IF SELLER HAS BEEN NEGLIGENT, WHETHER IN CONTRACT, TORT OR OTHER LEGAL THEORY. IN NO EVENT SHALL SELLER'S LIABILITY UNDER ANY CLAIM MADE BY BUYER EXCEED THE PURCHASE PRICE OF THE PRODUCTS.**

7. User Responsibility. The user, through its own analysis and testing, is solely responsible for making the final selection of the system and Product and assuring that all performance, endurance, maintenance, safety and warning requirements of the application are met. The user must analyze all aspects of the application and follow applicable industry standards and Product information. If Seller provides Product or system options, the user is responsible for determining that such data and specifications are suitable and sufficient for all applications and reasonably foreseeable uses of the Products or systems.

8. Loss to Buyer's Property. Any designs, tools, patterns, materials, drawings, confidential information or equipment furnished by Buyer or any other items which become Buyer's property, will be considered obsolete and may be destroyed by Seller after two consecutive years have elapsed without Buyer ordering the items manufactured using such property. Seller shall not be responsible for any loss or damage to such property while it is in Seller's possession or control.

9. Special Tooling. A tooling charge may be imposed for any special tooling, including without limitation, dies, fixtures, molds and patterns, acquired to manufacture Products. Such special tooling shall be and remain Seller's property notwithstanding payment of any charges by Buyer. In no event will Buyer acquire any interest in apparatus belonging to Seller which is utilized in the manufacture of the Products, even if such apparatus has been specially converted or adapted for such manufacture and notwithstanding any charges paid by Buyer. Unless otherwise agreed, Seller shall have the right to alter, discard or otherwise dispose of any special tooling or other property in its sole discretion at any time.

10. Buyer's Obligation; Rights of Seller. To secure payment of all sums due or otherwise, Seller shall retain a security interest in the goods delivered and this agreement shall be deemed a Security Agreement under the Uniform Commercial Code. Buyer authorizes Seller as its attorney to execute and file on Buyer's behalf all documents Seller deems necessary to perfect its security interest.

11. Improper use and Indemnity. Buyer shall indemnify, defend, and hold Seller harmless from any claim, liability, damages, lawsuits, and costs (including attorney fees), whether for personal injury, property damage, patent, trademark or copyright

infringement or any other claim, brought by or incurred by Buyer, Buyer's employees, or any other person, arising out of: (a) improper selection, improper application or other misuse of Products purchased by Buyer from Seller; (b) any act or omission, negligent or otherwise, of Buyer; (c) Seller's use of patterns, plans, drawings, or specifications furnished by Buyer to manufacture Product; or (d) Buyer's failure to comply with these terms and conditions. Seller shall not indemnify Buyer under any circumstance except as otherwise provided.

12. Cancellations and Changes. Orders shall not be subject to cancellation or change by Buyer for any reason, except with Seller's written consent and upon terms that will indemnify, defend and hold Seller harmless against all direct, incidental and consequential loss or damage. Seller may change product features, specifications, designs and availability with notice to Buyer.

13. Limitation on Assignment. Buyer may not assign its rights or obligations under this agreement without the prior written consent of Seller.

14. Force Majeure. Seller does not assume the risk and shall not be liable for delay or failure to perform any of Seller's obligations by reason of circumstances beyond the reasonable control of Seller (hereinafter "Events of Force Majeure"). Events of Force Majeure shall include without limitation: accidents, strikes or labor disputes, acts of any government or government agency, acts of nature, delays or failures in delivery from carriers or suppliers, shortages of materials, or any other cause beyond Seller's reasonable control.

15. Waiver and Severability. Failure to enforce any provision of this agreement will not waive that provision nor will any such failure prejudice Seller's right to enforce that provision in the future. Invalidation of any provision of this agreement by legislation or other rule of law shall not invalidate any other provision herein. The remaining provisions of this agreement will remain in full force and effect.

16. Termination. Seller may terminate this agreement for any reason and at any time by giving Buyer thirty (30) days written notice of termination. Seller may immediately terminate this agreement, in writing, if Buyer: (a) commits a breach of any provision of this agreement (b) appointments a trustee, receiver or custodian for all or any part of Buyer's property (c) files a petition for relief in bankruptcy on its own behalf, or by a third party (d) makes an assignment for the benefit of creditors, or (e) dissolves or liquidates all or a majority of its assets.

17. Governing Law. This agreement and the sale and delivery of all Products hereunder shall be deemed to have taken place in and shall be governed and construed in accordance with the laws of the State of Ohio, as applicable to contracts executed and wholly performed therein and without regard to conflicts of laws principles. Buyer irrevocably agrees and consents to the exclusive jurisdiction and venue of the courts of Cuyahoga County, Ohio with respect to any dispute, controversy or claim arising out of or relating to this agreement.

18. Indemnity for Infringement of Intellectual Property Rights. Seller shall have no liability for infringement of any patents, trademarks, copyrights, trade dress, trade secrets or similar rights except as provided in this Section. Seller will defend and indemnify Buyer against allegations of infringement of U.S. patents, U.S. trademarks, copyrights, trade dress and trade secrets ("Intellectual Property Rights"). Seller will defend at its expense and will pay the cost of any settlement or damages awarded in an action brought against Buyer based on an allegation that a Product sold pursuant to this Agreement infringes the Intellectual Property Rights of a third party. Seller's obligation to defend and indemnify Buyer is contingent on Buyer notifying Seller within ten (10) days after Buyer becomes aware of such allegations of infringement, and Seller having sole control over the defense of any allegations or actions including all negotiations for settlement or compromise. If a Product is subject to a claim that it infringes the Intellectual Property Rights of a third party, Seller may, at its sole expense and option, procure for Buyer the right to continue using the Product, replace or modify the Product so as to make it noninfringing, or offer to accept return of the Product and return the purchase price less a reasonable allowance for depreciation. Notwithstanding the foregoing, Seller shall have no liability for claims of infringement based on information provided by Buyer, or directed to Products delivered hereunder for which the designs are specified in whole or part by Buyer, or infringements resulting from the modification, combination or use in a system of any Product sold hereunder. The foregoing provisions of this Section shall constitute Seller's sole and exclusive liability and Buyer's sole and exclusive remedy for infringement of Intellectual Property Rights.

19. Entire Agreement. This agreement contains the entire agreement between the Buyer and Seller and constitutes the final, complete and exclusive expression of the terms of sale. All prior or contemporaneous written or oral agreements or negotiations with respect to the subject matter are herein merged.

20. Compliance with Law, U. K. Bribery Act and U.S. Foreign Corrupt Practices Act. Buyer agrees to comply with all applicable laws and regulations, including both those of the United Kingdom and the United States of America, and of the country or countries of the Territory in which Buyer may operate, including without limitation the U. K. Bribery Act, the U.S. Foreign Corrupt Practices Act ("FCPA") and the U.S. Anti-Kickback Act (the "Anti-Kickback Act"), and agrees to indemnify and hold harmless Seller from the consequences of any violation of such provisions by Buyer, its employees or agents. Buyer acknowledges that they are familiar with the provisions of the U. K. Bribery Act, the FCPA and the Anti-Kickback Act, and certifies that Buyer will adhere to the requirements thereof. In particular, Buyer represents and agrees that Buyer shall not make any payment or give anything of value, directly or indirectly to any governmental official, any foreign political party or official thereof, any candidate for foreign political office, or any commercial entity or person, for the purpose of influencing such person to purchase products or otherwise benefit the business of Seller.

Parker Hannifin Corporation
Miller Fluid Power Division
500 South Wolf Road
Des Plaines, IL 60016 USA
phone (847) 298-2400
fax (800) 892-1008
www.miller-fluidpower.com

Parker Hannifin Corporation
Motion and Control Division
160 Chisholm Drive
Milton, ON Canada L9T 3G9
direct (905) 693-3000
fax (905) 876-1958
www.parker.com

