

# CSP-SERIES

Crawl Space Sump Pump Kit

# Liberty Pumps®

A Family and Employee Owned Company

## 1/3 or 1/2 hp

For dewatering under homes, basements, crawl space areas or where water may accumulate.

### Features

- Heavy-duty submersible sump pump in 1/3 or 1/2 hp
- 15-3/4" x 16" perforated polyethylene sump pit with cover
- 24' x 1-1/4" flexible hose kit, polyethylene
- System is unassembled
- Check valve included

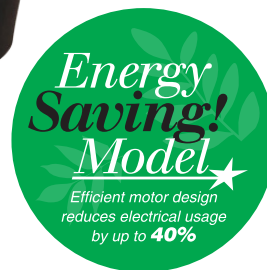

### Models

- |                |                                |
|----------------|--------------------------------|
| <b>CSP-237</b> | 1/3 hp Poly/Aluminum sump pump |
| <b>CSP-457</b> | 1/2 hp Poly/Aluminum sump pump |
| <b>CSP-257</b> | 1/3 hp Cast Iron sump pump     |

Controls problems with mold, fungus, moisture and structural damage. Reduces problems with rodents, insects and pests attracted to wet environments.



innovate. evolve.

# CSP-Series

## Kit Contents

- 15-3/4" x 16" Structural foam sump pit (perforated) and structural foam cover
- Automatic sump pump, 115V, with 10' power cord
- 24' Flexible hose kit, polyethylene 1-1/4" (Model DHK-24)
- Check valve threads directly into pump discharge

**Note:** System is unassembled

## Dimensional Data

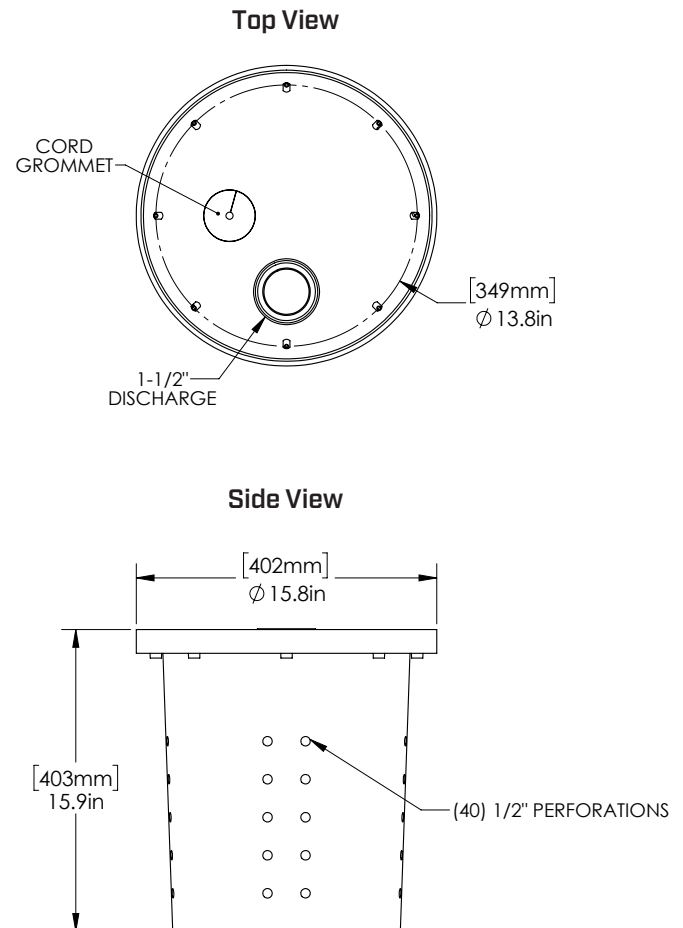

## Performance Curve

60 Hz

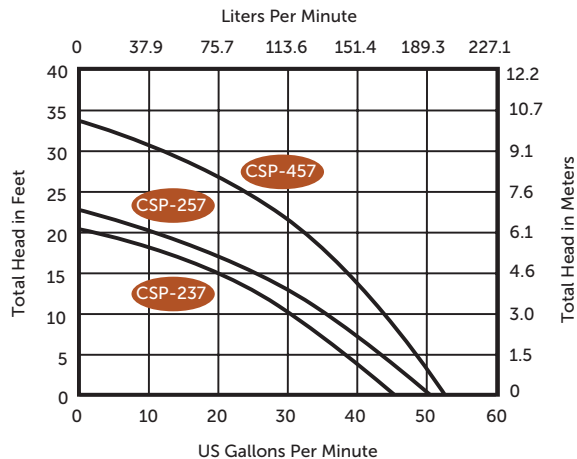

## Max Fluid Temperature

140°F (60°C) Intermittent

## Models

MODEL	HP	VOLT	PUMP	PUMP MATERIAL	SYSTEM WEIGHT
CSP-237	1/3	115	237	Poly/aluminum	23 lbs
CSP-457	1/2	115	457	Poly/aluminum	25 lbs
CSP-257	1/3	115	257	Cast iron	30 lbs

Add "-2" to CSP-237 model for a 25' cord. Example: CSP-237-2

See specific 230-Series, 250-Series or 450-Series literature for complete pump specifications.