

## Pneumatic Division

Richland, Michigan USA

[www.parker.com/pneumatics](http://www.parker.com/pneumatics)



### CYCLONE VALVE SERIES

Bulletin Number		Bulletin Description
<input type="checkbox"/>	V640P	General Purpose Valves, UL/CSA Data Sheet
<input type="checkbox"/>	V641P Rev. 8	Direct Acting Solenoids Valve, Installation & Service Instructions
<input type="checkbox"/>	V642P Rev. 4	Direct Acting Solenoids Valve, Installation & Service Instructions
<input type="checkbox"/>	V649P Rev. 2	Direct Acting Hazardous Duty Valve, Installation & Service Instructions
<input type="checkbox"/>	Safety Guide	PDN Safety Guide



Pneumatic Division  
North America  
Richland, MI 49083

UL/CSA Data Sheet: V-640P

General Purpose Valves

ISSUED: April, 1999

Supersedes: 74000-7011  
June, 1998

ECN# 9071

## General Purpose Valves

### Approval Agencies Laboratory Data On Electrically Operated Valves

#### Listed Under

**U.L. File Number MH7261, Guide Card YIOZ**

**CSA File Number LR50892, Guide Card 440-A-O**

**The information contained herein is in accordance with the applicable approval agencies requirements governing the final form of listing mark (UL, CSA, or UL/CSA Symbol).**

The types of fluid for which this valve is listed.

The types of fluid for which this valve is listed is indicated in the symbols having the following significance.

- A - Air or nontoxic, nonflammable gases.
- F - Common refrigerants except ammonia.
- G - City gas supplied by public utilities.
- LP - Liquefied petroleum gases.
- 02 - Nos. 1 and 2 fuel oils, oils having viscosities not more than 40 SSU at 100°F.
- W - Water or other aqueous nonflammable liquids.

**The maximum fluid and ambient temperature rating for which the valve is listed is 77°F.**



**Pneumatic Division North America**  
 Richland, Michigan 49083

**Installation & Service Instructions**  
**V-641P**

**Direct Acting Solenoid Valve**

**ISSUED: May, 2001**  
**Supersedes: July, 1999**

ECN# P28246 Rev. 8

**WARNING**

To avoid unpredictable system behavior that can cause personal injury and property damage:

- Disconnect electrical supply (when necessary) before installation, servicing, or conversion.
- Disconnect air supply and depressurize all air lines connected to this product before installation, servicing, or conversion.
- Operate within the manufacturer's specified pressure, temperature, and other conditions listed in these instructions.
- Medium must be moisture-free if ambient temperature is below freezing.
- Service according to procedures listed in these instructions.
- Installation, service, and conversion of these products must be performed by knowledgeable personnel who understand how pneumatic products are to be applied.
- After installation, servicing, or conversion, air and electrical supplies (when necessary) should be connected and the product tested for proper function and leakage. If audible leakage is present, or the product does not operate properly, do not put into use.
- Warnings and specifications on the product should not be covered by paint, etc. If masking is not possible, contact your local representative for replacement labels.

**Application Limits:**

**Operating Pressure Range** - Vacuum to the maximum operating pressure differential (M.O.P.D.) assigned to the orifice structure chosen from chart below. M.O.P.D. is the maximum allowable difference between pressures recorded at any two working ports of the valve. If the M.O.P.D. is not known, regard the M.O.P.D. as the supply pressure.

Stop Orifice (Cv)	Body Orifice (Cv)										
	1/32" (.02)	3/64" (.06)	3/64" (.06)	1/16" (.10)	1/16" (.10)	3/32" (.20)	1/8" (.32)	1/8" (.32)	5/32" (.42)	3/16" (.52)	7/32" (.73)
1/32" (.02)	•										
3/64" (.06)		•		•							
1/16" (.12)			•		•		•				
3/32" (.21)						•		•	•	•	•
Function	M.O.P.D. AC / DC (PSIG)										
2-Way, Normally Closed*	500	250	—	200	—	125	—	—	75/50	50/25	25/10
2-Way, Normally Open**	300	200	—	150	—	125	—	—	—	—	—
3-Way, Normally Closed	250	—	175	—	125	90	—	65	40	20	10
3-Way, Normally Open	200	—	—	150	—	—	100	75	50	25	10
3-Way, Multi-Purpose	250	150	—	—	100	75	—	50	30	10	10
3-Way, Directional Control	300	200	—	—	150	125	—	100	75	50	—

\* On 2-Way, Normally Closed Valves, the Stop Orifice is blank.

\*\* On 2-Way, Normally Open Valves, the Body Orifice is blank.

**Operating Temperature Range (Ambient):**

**Continuous Duty**

- Class "B" Coils -7°C to 52°C (20°F to 125°F)
- Class "H" Coils, Viton Seals -7°C to 82°C (20°F to 180°F)

**Intermittent Duty**

- Class "B" Coils -7°C to 82°C (20°F to 180°F)
- Class "H" Coils, Viton Seals -7°C to 132°C (20°F to 270°F)

**Voltage Range:** +10% to -15% of rating.

**ANSI Symbols:**

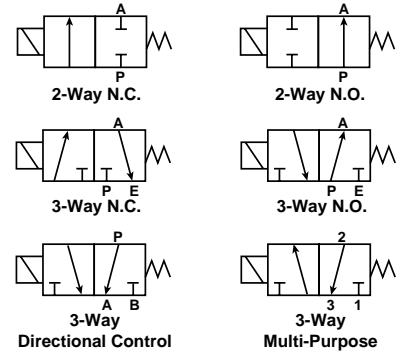

P - Inlet  
 A - Cylinder  
 E - Exhaust

**Installation & Operating Instructions:**

Valve should be installed with reasonable accessibility for service whenever possible — repair service kits are available. Keep pipe or tubing lengths to a minimum with inside clean and free of dirt and chips. Pipe joint compound should be used sparingly and applied only to the male pipe — never into the female port. Do not use PTFE tape to seal pipe joints — pieces have a tendency to break off and lodge inside the unit, possibly causing malfunction.

Air applied to the valve must be filtered to realize maximum component life.

**Life Expectancy** - Normal multi-million cycle life expectancy of these valves is based on the use of properly filtered and lubricated air at room temperature. These valves are also designed to operate under non-lubricated conditions and will yield millions of maintenance free cycles.

**Factory Pre-Lubrication** - All valves are pre-lubricated at assembly with Sunaplex 781 or equivalent (Petroleum Base - Lithium Content) grease.

**In-Service Lubrication** - In-Service lubrication is not required; however, if lubrication is to be used, F442 oil is recommended. This oil is specially formulated to provide peak performance and maximum service life from all air operated equipment. Otherwise, use a straight paraffin base mineral oil of viscosity 100-200 SSU @ 100°F and aniline point greater than 200°F.

**WARNING**

**FAILURE OR IMPROPER SELECTION OR IMPROPER USE OF THE PRODUCTS AND/OR SYSTEMS DESCRIBED HEREIN OR RELATED ITEMS CAN CAUSE DEATH, PERSONAL INJURY AND PROPERTY DAMAGE.**

This document and other information from Parker Hannifin Corporation, its subsidiaries and authorized distributors provide product and/or system options for further investigation by users having technical expertise. It is important that you analyze all aspects of your application, including consequences of any failure and review the information concerning the product or systems in the current product catalog. Due to the variety of operating conditions and applications for these products or systems, the user, through its own analysis and testing, is solely responsible for making the final selection of the products and systems and assuring that all performance, safety and warning requirements of the application are met.

The products described herein, including without limitation, product features, specifications, designs, availability and pricing, are subject to change by Parker Hannifin Corporation and its subsidiaries at any time without notice.

**EXTRA COPIES OF THESE INSTRUCTIONS ARE AVAILABLE FOR INCLUSION IN EQUIPMENT / MAINTENANCE MANUALS THAT UTILIZE THESE PRODUCTS. CONTACT YOUR LOCAL REPRESENTATIVE.**

**Direct Acting Solenoid Valve**

**Wiring Instructions:**

Connect the two wires to suitable supply voltage. Either may be "Hot".

**⚠ Earth Ground** - When an earth ground is required for a two wire system, connect a copper ground wire to one of the mounting holes located on the valve body. This ground connection must be secure, and must be identified as a grounding connection. The installer must ensure minimum impedance of this ground circuit.

**⚠ CAUTION: An interruption of 10 milliseconds or greater to the power supplied to the solenoid of a solenoid operated valve may cause the valve to shift. Provision must be made to prevent power interruption of this duration to avoid unintended, potentially hazardous, consequences.**

**NOTE:** In addition to above instructions, follow all requirements for local and national electrical codes.

**Service Procedures**

**NOTE:** All cleaning of parts to be done with mineral spirits or equivalent cleaning solution. Grease should be a mineral based lubricant (Sunaplex 781).

**General Service** - Remove exhaust adapter (A) - where applicable and hex nut (B) on top of valve or operator. Separate the housing and coil assembly from the plunger guide (D). Remove the flux washer (C) - where applicable. Remove the plunger guide (D), spring (E), o-ring (F) and plunger (G). Use spanner wrench No. 740007100. Clean all parts taking special care to remove all foreign matter from seat areas.

**Coil Replacement (Conduit or Grommet)** - Remove coil (H) through bottom of housing and replace with new coil.

**Coil Replacement (Hazardous Duty)** - Remove cap (J) and spacer (K). Remove coil (H) through top of housing and replace with new coil. Assemble in reverse order of disassembly.

**V-641P**

**Coil Replacement (J.I.C.)** - Loosen cover screws (L) and remove cover assembly. Remove flux washer (C), coil (H) and wave washers (M). Replace with new one. Assemble in reverse order of disassembly.

Replace plunger and guide (See Kit Selection), or entire operator. Assemble parts in reverse order of disassembly. Tighten hex nut 2.3 to 2.8 Nm (20 to 25 in-lb). Assemble exhaust adaptor and tighten 2.3 to 2.8 Nm (20 to 25 in-lb) for Hazardous Duty Enclosures (hand tight is sufficient with other enclosures).

**Indicator Light Replacement**

Indicator Lights

120V 60 Hz/ 110V 50 Hz .....	H19109
24VDC .....	H19110

1. Remove dome nut (B), loosen cover screws (L) and remove cover assembly (N).

2. **Units with Flying Leads** - Snap open splice connectors and pry out of splice. Slide wires out of splice.

**Units with 3-Pin or 5-Pin Connectors** - Twist off two wire nuts (P) connected to lamp leads.

3. Crush lens of indicator light (Q), pull out of cover and retain o-ring (R).

4. Strip insulation off of indicator light lead wires 1/2". Slide o-ring onto new lamp and slide thru hole in cover.

5. **Units with Flying Leads** - Slide one indicator light wire into each splice. Connect red coil lead with red lamp lead and white coil lead with white lamp lead. Place clip into splice and press until flush with top of splice (vice or long-handled pliers required). Snap splice housing shut.

**Units with 3-Pin or 5-Pin Connectors** - Reconnect leads with wire nuts per wiring diagram found on cover assembly.

6. Reassemble junction box cover and tighten screws 2.3 to 2.8 Nm (20 to 25 in-lb). Screw on dome nut.

**Repair Kits:**

Function	Stop Orifice				
	1/32"	3/64"	1/16"	3/32"	None
3-Way, N.C.	744008031	744008046	744008062	744008093	—
3-Way, N.O.	742008031	742008046	742008062	742008093	—
3-Way, Multi-Purpose	745008031	745008046	745008062	745008093	—
2-Way, N.O. & 3-Way, Directional Control	746008031	746008046	746008062	746008093	—
2-Way, N.C.	—	—	—	—	741008000

**NOTE:** For Viton seals, change the 7th digit in part number from "0" to "6".

**EXAMPLE:** 744008031 would be 744008631 for Viton seals.

Exhaust Adapter (Includes O-ring)	1/8" Pipe	1/4" Pipe
	744008000 (Buna)	744108000 (Buna)
	744008600 (Viton)	744108600 (Viton)

**Coils:**

Voltage / Hertz	Class "B"	Class "H"	Class "B" Spade
6V/60Hz	740007141	740007291	780007141
12V/60Hz	740007142	740007292	780007142
24V/60Hz; 6VDC	740007143	740007293	780007143
48V/60Hz	740007152	740007202	780007152
120V/60Hz	740007145	740007295	780007145
240V/60Hz	740007146	740007296	780007146
480V/60Hz	740007147	740007297	780007147
12VDC	740007152	740007202	780007152
24VDC	740007153	740007203	780007153
120VDC	740007155	740007205	780007155
230VDC	740007156	740007206	780007156
120V/50Hz	740007165	—	—
240V/50Hz	740007166	—	—
440V/50Hz	740007167	—	—

**Conduit**

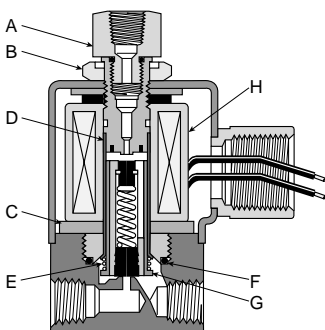

**Hazardous Duty**

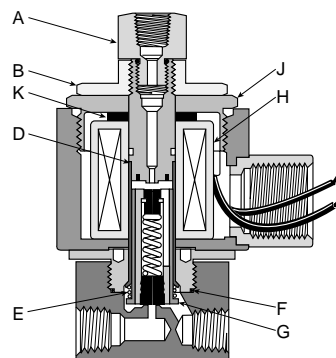

**J.I.C.**

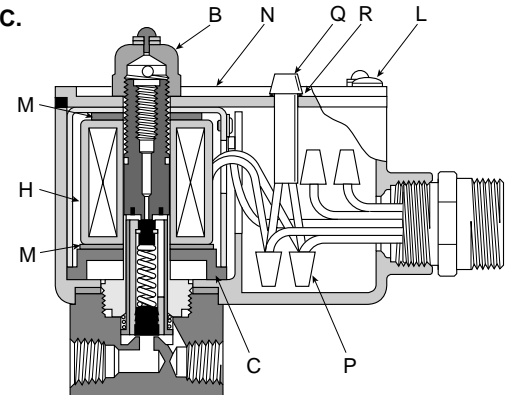



**Pneumatic Division**  
Richland, Michigan 49083

**Installation & Service Instructions**  
**V642P**

**Direct Acting Solenoid Valve**

**ISSUED: April, 2003**  
**Supersedes: February, 2002**

**Doc.# V-642, ECN# 030310, Rev. 4**

**⚠ WARNING**

To avoid unpredictable system behavior that can cause personal injury and property damage:

- Disconnect electrical supply (when necessary) before installation, servicing, or conversion.
- Disconnect air supply and depressurize all air lines connected to this product before installation, servicing, or conversion.
- Operate within the manufacturer's specified pressure, temperature, and other conditions listed in these instructions.
- Medium must be moisture-free if ambient temperature is below freezing.
- Service according to procedures listed in these instructions.
- Installation, service, and conversion of these products must be performed by knowledgeable personnel who understand how pneumatic products are to be applied.
- After installation, servicing, or conversion, air and electrical supplies (when necessary) should be connected and the product tested for proper function and leakage. If audible leakage is present, or the product does not operate properly, do not put into use.
- Warnings and specifications on the product should not be covered by paint, etc. If masking is not possible, contact your local representative for replacement labels.

**Application Limits:**

**Operating Pressure Range** – Vacuum to the maximum operating pressure differential (M.O.P.D.) assigned to the orifice structure chosen from chart below. M.O.P.D. is the maximum allowable difference between pressures recorded at any two working ports of the valve. If the M.O.P.D. is not known, regard the M.O.P.D. as the supply pressure.

Stop Orifice (Cv)	Body Orifice (Cv)										
	1/32" (.02)	3/64" (.06)	3/64" (.06)	1/16" (.10)	1/16" (.10)	3/32" (.20)	1/8" (.32)	1/8" (.32)	5/32" (.42)	3/16" (.52)	7/32" (.73)
1/32" (.02)	•										
3/64" (.06)		•		•							
1/16" (.12)			•		•		•				
3/32" (.21)						•		•	•	•	•
Function	M.O.P.D. AC / DC (PSIG)										
2-Way, Normally Closed*	500	250	250	200	200	125	100	100	75/50	50/25	25/10
2-Way, Normally Open**	300	200	200	150	200	125	—	—	—	—	—
3-Way, Normally Closed	250	175	175	—	125	90	65	65	40	20	10
3-Way, Normally Open	200	—	100	150	100	75	100	75	50	25	10
3-Way, Multi-Purpose	250	150	100	—	100	75	65	50	30	10	10
3-Way, Directional Control	300	200	150	—	150	125	100	100	75	50	10

\* On 2-Way, Normally Closed Valves, the Stop Orifice is blank.  
\*\* On 2-Way, Normally Open Valves, the Body Orifice is blank.

**Operating Temperature Range (Ambient):**

**Continuous Duty**

- Class "F" Coils -7°C to 52°C (20°F to 125°F)
- Class "H" Coils, Viton Seals -7°C to 82°C (20°F to 180°F)

**Intermittent Duty**

- Class "F" Coils -7°C to 82°C (20°F to 180°F)
- Class "H" Coils, Viton Seals -7°C to 132°C (20°F to 270°F)

**Voltage Range:** +10% to -15% of rating.

**ANSI Symbols:**

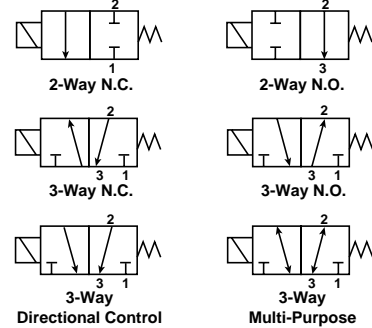

**Installation & Operating Instructions:**

Valve should be installed with reasonable accessibility for service whenever possible — repair service kits are available. Keep pipe or tubing lengths to a minimum with inside clean and free of dirt and chips. Pipe joint compound should be used sparingly and applied only to the male pipe — never into the female port. Do not use PTFE tape to seal pipe joints — pieces have a tendency to break off and lodge inside the unit, possibly causing malfunction.

Air applied to the valve must be filtered to realize maximum component life.

**Life Expectancy** – Normal multi-million cycle life expectancy of these valves is based on the use of properly filtered and lubricated air at room temperature. These valves are also designed to operate under non-lubricated conditions and will yield millions of maintenance free cycles.

**Factory Pre-Lubrication** – All valves are pre-lubricated at assembly with Accrolube or equivalent (Petroleum Base - Lithium Content) grease.

**In-Service Lubrication** – In-Service lubrication is not required; however, if lubrication is to be used, F442 oil is recommended. This oil is specially formulated to provide peak performance and maximum service life from all air operated equipment. Otherwise, use a straight paraffin base mineral oil of viscosity 100-200 SSU @ 100°F and aniline point greater than 200°F.

**⚠ WARNING**

**FAILURE OR IMPROPER SELECTION OR IMPROPER USE OF THE PRODUCTS AND/OR SYSTEMS DESCRIBED HEREIN OR RELATED ITEMS CAN CAUSE DEATH, PERSONAL INJURY AND PROPERTY DAMAGE.**

This document and other information from Parker Hannifin Corporation, its subsidiaries and authorized distributors provide product and/or system options for further investigation by users having technical expertise. It is important that you analyze all aspects of your application, including consequences of any failure and review the information concerning the product or systems in the current product catalog. Due to the variety of operating conditions and applications for these products or systems, the user, through its own analysis and testing, is solely responsible for making the final selection of the products and systems and assuring that all performance, safety and warning requirements of the application are met.

The products described herein, including without limitation, product features, specifications, designs, availability and pricing, are subject to change by Parker Hannifin Corporation and its subsidiaries at any time without notice.

**EXTRA COPIES OF THESE INSTRUCTIONS ARE AVAILABLE FOR INCLUSION IN EQUIPMENT / MAINTENANCE MANUALS THAT UTILIZE THESE PRODUCTS. CONTACT YOUR LOCAL REPRESENTATIVE.**

**Wiring Instructions:**

Connect the two wires to suitable supply voltage. Either may be "Hot".

**⚠ Earth Ground** – When an earth ground is required for a two wire system, connect a copper ground wire to one of the mounting holes located on the valve body. This ground connection must be secure, and must be identified as a grounding connection. The installer must ensure minimum impedance of this ground circuit.

**⚠ CAUTION: An interruption of 10 milliseconds or greater to the power supplied to the solenoid of a solenoid operated valve may cause the valve to shift. Provision must be made to prevent power interruption of this duration to avoid unintended, potentially hazardous, consequences.**

**NOTE:** In addition to above instructions, follow all requirements for local and national electrical codes.

**Service Procedures**

**NOTE:** All cleaning of parts to be done with mineral spirits or equivalent cleaning solution. Grease should be a mineral based lubricant (Sunaplex 781).

**General Service** – Remove Exhaust Adapter (A), O-ring (K) - where applicable, Hex Nut (B) and Washer (C) on top of Solenoid. Separate the Solenoid Assembly (D) from the Valve Body (E) and Plunger Guide (F). Remove the Plunger Guide (F), Spring (G), O-ring (H) and Plunger (J). Use spanner wrench No. 740007100B. Clean all parts taking special care to remove all foreign matter from seat areas.

**Solenoid Replacement** – Remove Exhaust Adapter (A), O-ring (K) - where applicable, Hex Nut (B) and Washer (C) on top of Solenoid. Separate the Solenoid Assembly (D) from the Valve Body (E) and Plunger Guide (F). Place new Solenoid Assembly (D) onto Plunger Guide (F). Replace Washer (C). Replace Nut (B) and tighten to 2.3 to 2.8 Nm (20 to 25 in. lb.). Where applicable, replace O-ring (K), Exhaust Adapter (A) and hand tighten. The Plunger Guide (F) must be torqued to 6.7 to 9.0 Nm (60 to 80 in. lb.).

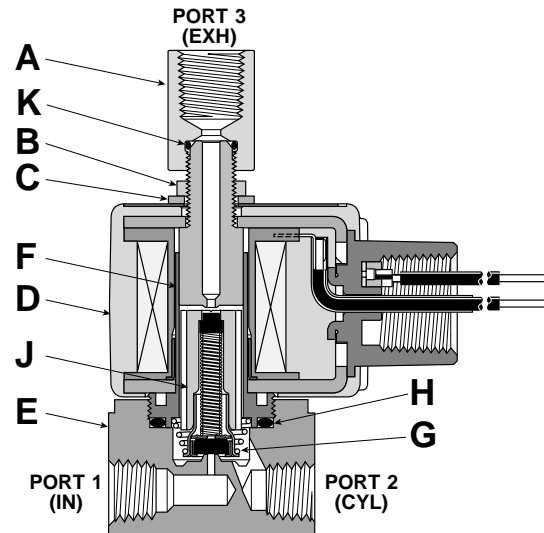

**Service Kits**

In addition to the kits configurable from the matrix below, the following kits are also provided.

Kit Number	Description	Included Items
PS3901P	1/8" Connector Kit	A & K
PS3902P	1/4" Connector Kit	A & K
740007100B	Assembly Wrench	Not Shown

Basic Series	Kit Type	Solenoid Type	Valve Type	Orifice Diameter	Seals	Coil Class	Voltage	Parker																																						
<b>PS39</b>	<b>1</b>	<b>4</b>	<b>X</b>	<b>X</b>	<b>X</b>	<b>1</b>	<b>5</b>	<b>P</b>																																						
<b>Basic Series</b> PS39 Direct Solenoid Valve	<b>Kit Type (See Below)</b> 1 Solenoid Only* 2 Plunger / Stop Assy Only** 3 1 + 2 (Solenoid with Plunger & Stop Assy)	<b>Solenoid Type</b> 4 Conduit 5 Grommet X Plunger & Stop Assy Only Select only 4 or 5 when Kit Type is 1 or 3. Select X for Kit Type 2.	<b>Valve Type</b> 0 2-Way Normally Open 1 2-Way Normally Closed 2 3-Way Normally Open 3 3-Way Normally Closed, Free Vent 4 3-Way Normally Closed, Piped Exhaust 5 3-Way Multi-Purpose 6 3-Way Directional Control X Solenoid Only Select only 0 thru 6 when Kit Type is 2 or 3. Select X for Kit Type 1.	<b>Orifice Diameter</b> <table border="1"> <thead> <tr> <th>Body</th> <th>Stop</th> </tr> </thead> <tbody> <tr><td>0</td><td>1/32 1/32</td></tr> <tr><td>1</td><td>3/64 3/64</td></tr> <tr><td>1*</td><td>1/16 3/64</td></tr> <tr><td>2</td><td>3/64 1/16</td></tr> <tr><td>3</td><td>1/16 1/16</td></tr> <tr><td>4</td><td>3/32 3/32</td></tr> <tr><td>5</td><td>1/8 1/16</td></tr> <tr><td>6</td><td>1/8 3/32</td></tr> <tr><td>7</td><td>5/32 3/32</td></tr> <tr><td>8</td><td>3/16 3/32</td></tr> <tr><td>9</td><td>7/32 3/32</td></tr> <tr><td>X</td><td>Solenoid Only</td></tr> </tbody> </table> * Used on Valve Type 2, Normally Open, 3-Way valves only. Select X when Kit Type is 1. Select 0 thru 9 when Kit Type is 2 or 3.	Body	Stop	0	1/32 1/32	1	3/64 3/64	1*	1/16 3/64	2	3/64 1/16	3	1/16 1/16	4	3/32 3/32	5	1/8 1/16	6	1/8 3/32	7	5/32 3/32	8	3/16 3/32	9	7/32 3/32	X	Solenoid Only	<b>Seals</b> 1 Buna N 2 Viton X Solenoid Only Select X when Kit Type is 1. Select 1 or 2 when Kit Type is 2 or 3.	<b>Coil Class</b> <table border="1"> <thead> <tr> <th>Class</th> <th>Hertz</th> </tr> </thead> <tbody> <tr><td>1</td><td>F 60</td></tr> <tr><td>2</td><td>F DC</td></tr> <tr><td>9</td><td>H 60</td></tr> <tr><td>0</td><td>H DC</td></tr> <tr><td>X</td><td>Plunger &amp; Stop Assy Only</td></tr> </tbody> </table> Select X when Kit Type is 2. Select the other Options when Kit Type is 1 or 3.	Class	Hertz	1	F 60	2	F DC	9	H 60	0	H DC	X	Plunger & Stop Assy Only	<b>Voltage</b> 2* 12 3 24 5** 120 (110) 6** 240 (220) X Plunger & Stop Assy Only * Not available with Coil Class 1 or 9. ** Not available with Coil Class 2 or 0. Select X when Kit Type is 2. Select the other Options when Kit Type is 1 or 3.	
Body	Stop																																													
0	1/32 1/32																																													
1	3/64 3/64																																													
1*	1/16 3/64																																													
2	3/64 1/16																																													
3	1/16 1/16																																													
4	3/32 3/32																																													
5	1/8 1/16																																													
6	1/8 3/32																																													
7	5/32 3/32																																													
8	3/16 3/32																																													
9	7/32 3/32																																													
X	Solenoid Only																																													
Class	Hertz																																													
1	F 60																																													
2	F DC																																													
9	H 60																																													
0	H DC																																													
X	Plunger & Stop Assy Only																																													

**Engineering Level "B" valves can use Kit Types: 1, 2, or 3.**  
**All other valves ONLY use Kit Type 3.**  
**Example:**  
 For Valve Model Number 745030115:  
**The Only Kit Is PS393453115P**  
**Example:**  
 For Valve Model Number 745030115B:  
 The Solenoid Assy. No. Is **PS3914XXX15P**  
 The Plunger Stop Assy. No. Is **PS392X531XXP**

**⚠ WARNING**

To avoid unpredictable system behavior that can cause personal injury and property damage:

- Disconnect electrical supply (when necessary) before installation, servicing, or conversion.
- Disconnect air supply and depressurize all air lines connected to this product before installation, servicing, or conversion.
- Operate within the manufacturer's specified pressure, temperature, and other conditions listed in these instructions.
- Medium must be moisture-free if ambient temperature is below freezing.
- Service according to procedures listed in these instructions.
- Installation, service, and conversion of these products must be performed by knowledgeable personnel who understand how pneumatic products are to be applied.
- After installation, servicing, or conversion, air and electrical supplies (when necessary) should be connected and the product tested for proper function and leakage. If audible leakage is present, or the product does not operate properly, do not put into use.
- Warnings and specifications on the product should not be covered by paint, etc. If masking is not possible, contact your local representative for replacement labels.

**Safety Guide**

For more complete information on recommended application guidelines, see the Safety Guide section of Pneumatic Division catalogs or you can download the **Pneumatic Division Safety Guide** at: [www.parker.com/safety](http://www.parker.com/safety)

**Application Limits:**

**Operating Pressure Range** – Vacuum to the maximum operating pressure differential (M.O.P.D.) assigned to the orifice structure chosen from chart below. M.O.P.D. is the maximum allowable difference between pressures recorded at any two working ports of the valve. If the M.O.P.D. is not known, regard the M.O.P.D. as the supply pressure.

Stop Orifice (Cv)	Body Orifice (Cv)									
	1/32" (.02)	3/64" (.06)	3/64" (.06)	1/16" (.10)	1/16" (.10)	3/32" (.20)	1/8" (.32)	1/8" (.32)	5/32" (.42)	3/16" (.52)
1/32" (.02)	•									
3/64" (.06)		•		•						
1/16" (.12)			•		•		•			
3/32" (.21)						•		•	•	•
Function	M.O.P.D. AC / DC (PSIG)									
2-Way, Normally Closed*	—	250	—	200	200	125	100	100	75/50	50/25
2-Way, Normally Open**	—	200	200	150	150	125	—	—	—	—
3-Way, Normally Closed	—	—	175	—	125	90	—	65	40	20
3-Way, Normally Open	—	150	—	—	—	—	100	75	—	—
3-Way, Multi-Purpose	250	150	—	—	100	75	—	—	—	—
3-Way, Directional Control	—	—	—	—	150	125	—	100	—	—

\* On 2-Way, Normally Closed Valves, the Stop Orifice is blank.

\*\*On 2-Way, Normally Open Valves, the Body Orifice is blank.

**Operating Temperature Range (Ambient):**  
**Continuous Duty**

- Class "F" Coils -7°C to 52°C (20°F to 125°F)
- Class "H" Coils, Viton Seals -7°C to 82°C (20°F to 180°F)

**Intermittent Duty**

- Class "F" Coils -7°C to 82°C (20°F to 180°F)
- Class "H" Coils, Viton Seals -7°C to 132°C (20°F to 270°F)

**Voltage Range:** +10% to -15% of rating.

**ANSI Symbols:**

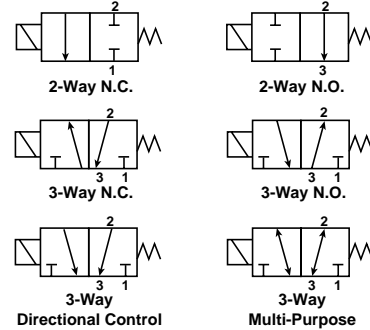

**Installation & Operating Instructions:**

Valve should be installed with reasonable accessibility for service whenever possible — repair service kits are available. Keep pipe or tubing lengths to a minimum with inside clean and free of dirt and chips. Pipe joint compound should be used sparingly and applied only to the male pipe — never into the female port. Do not use PTFE tape to seal pipe joints — pieces have a tendency to break off and lodge inside the unit, possibly causing malfunction.

Air applied to the valve must be filtered to realize maximum component life.

**Life Expectancy** – Normal multi-million cycle life expectancy of these valves is based on the use of properly filtered and lubricated air at room temperature. These valves are also designed to operate under non-lubricated conditions and will yield millions of maintenance free cycles.

**Factory Pre-Lubrication** – All valves are pre-lubricated at assembly with Accrolube or equivalent (Petroleum Base - Lithium Content) grease.

**In-Service Lubrication** – In-Service lubrication is not required; however, if lubrication is to be used, F442 oil is recommended. This oil is specially formulated to provide peak performance and maximum service life from all air operated equipment. Otherwise, use a straight paraffin base mineral oil of viscosity 100-200 SSU @ 100°F and aniline point greater than 200°F.

**⚠ WARNING**

**FAILURE OR IMPROPER SELECTION OR IMPROPER USE OF THE PRODUCTS AND/OR SYSTEMS DESCRIBED HEREIN OR RELATED ITEMS CAN CAUSE DEATH, PERSONAL INJURY AND PROPERTY DAMAGE.**

This document and other information from Parker Hannifin Corporation, its subsidiaries and authorized distributors provide product and/or system options for further investigation by users having technical expertise. It is important that you analyze all aspects of your application, including consequences of any failure and review the information concerning the product or systems in the current product catalog. Due to the variety of operating conditions and applications for these products or systems, the user, through its own analysis and testing, is solely responsible for making the final selection of the products and systems and assuring that all performance, safety and warning requirements of the application are met.

The products described herein, including without limitation, product features, specifications, designs, availability and pricing, are subject to change by Parker Hannifin Corporation and its subsidiaries at any time without notice.

**EXTRA COPIES OF THESE INSTRUCTIONS ARE AVAILABLE FOR INCLUSION IN EQUIPMENT / MAINTENANCE MANUALS THAT UTILIZE THESE PRODUCTS. CONTACT YOUR LOCAL REPRESENTATIVE.**

### Wiring Instructions:

Connect the two wires to suitable supply voltage. Either may be "Hot".

**⚠ Caution: Prevent igniting haz. ATM. Keep tightly closed when alive & disconnect circuit before opening case.**

**ATTN: Garder Le Couverde bein ferme Lorsque Les circuits sont sous tension.**

**General purpose valve for use in haz. locations. Cl. I, GR. C & D, Cl. II, GR. E, F & G, OP. TEMP. CODE T4A.**

**⚠ Earth Ground** – When an earth ground is required for a two wire system, connect a copper ground wire to one of the mounting holes located on the valve body. This ground connection must be secure, and must be identified as a grounding connection. The installer must ensure minimum impedance of this ground circuit.

**⚠ CAUTION: An interruption of 10 milliseconds or greater to the power supplied to the solenoid of a solenoid operated valve may cause the valve to shift. Provision must be made to prevent power interruption of this duration to avoid unintended, potentially hazardous, consequences.**

**NOTE:** In addition to above instructions, follow all requirements for local and national electrical codes.

### Hazardous Duty Qualification

- Class I Groups A, B, C, D
- Class II Groups E, F, G
- Temperature: T3A
- UL Listed File # E40014

### Service Kits

In addition to the kits configurable from the matrix below, the following kits are also provided.

Kit Number	Description	Included Items
PS3901P	1/8" Connector Kit	A & K
PS3902P	1/4" Connector Kit	A & K
740007100B	Assembly Wrench	Not Shown

### Service Procedures

**NOTE:** All cleaning of parts to be done with mineral spirits or equivalent cleaning solution. Grease should be a mineral based lubricant (Sunplex 781).

**General Service** – Remove Exhaust Adapter (A), O-ring (K) - where applicable, Hex Nut (B) and Washer (C) on top of Solenoid. Separate the Solenoid Assembly (D) from the Valve Body (E) and Plunger Guide (F). Remove the Plunger Guide (F), Spring (G), O-ring (H) and Plunger (J). Use spanner wrench No. 740007100B. Clean all parts taking special care to remove all foreign matter from seat areas.

**Solenoid Replacement** – Remove Exhaust Adapter (A), O-ring (K) - where applicable, Hex Nut (B) and Washer (C) on top of Solenoid. Separate the Solenoid Assembly (D) from the Valve Body (E) and Plunger Guide (F). Place new Solenoid Assembly (D) onto Plunger Guide (F). Replace Washer (C). Replace Nut (B) and tighten to 2.3 to 2.8 Nm (20 to 25 in. lb.). Where applicable, replace O-ring (K), Exhaust Adapter (A) and tighten to 2.3 to 2.8 Nm (20 to 25 in. lb.). The Plunger Guide (F) must be torqued to 6.7 to 9.0 Nm (60 to 80 in. lb.).

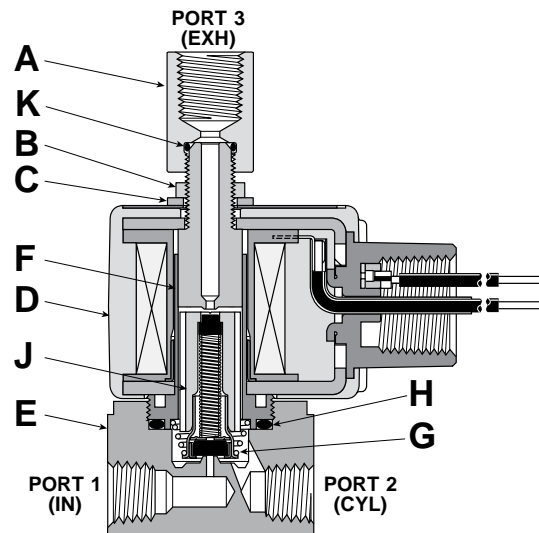

Basic Series	Kit Type	Solenoid Type	Valve Type	Orifice Diameter	Seals	Coil Class	Voltage	Parker																																												
<b>PS19</b>	<b>1</b>	<b>6</b>	<b>X</b>	<b>X</b>	<b>X</b>	<b>1</b>	<b>5</b>	<b>P</b>																																												
<b>Basic Series</b> PS19 Direct Solenoid Valve	<b>Kit Type (See Below)</b> 1 Solenoid Only* 2 Plunger / Stop Assy Only** 3 1 + 2 (Solenoid with Plunger & Stop Assy)	<b>Solenoid Type</b> 6 Hazardous Duty X Plunger & Stop Assy Only Select only 6 when Kit Type is 1 or 3. Select X for Kit Type 2.	<b>Valve Type</b> 0 2-Way Normally Open 1 2-Way Normally Closed 2 3-Way Normally Open 3 3-Way Normally Closed, Free Vent 4 3-Way Normally Closed, Piped Exhaust 5 3-Way Multi-Purpose 6 3-Way Directional Control X Solenoid Only Select only 0 thru 6 when Kit Type is 2 or 3. Select X for Kit Type 1.	<b>Orifice Diameter</b> <table border="1"> <thead> <tr> <th>Body</th> <th>Stop</th> <th>Only Available with Valve Type</th> </tr> </thead> <tbody> <tr><td>0</td><td>1/32</td><td>1/32</td></tr> <tr><td>1</td><td>3/64</td><td>3/64</td></tr> <tr><td>1</td><td>3/64</td><td>1/16</td></tr> <tr><td>3</td><td>1/8</td><td>1/16</td></tr> <tr><td>3</td><td>1/16</td><td>1/16</td></tr> <tr><td>4</td><td>1/8</td><td>3/32</td></tr> <tr><td>4</td><td>3/32</td><td>3/32</td></tr> <tr><td>6</td><td>1/8</td><td>3/32</td></tr> <tr><td>7</td><td>5/32</td><td>3/32</td></tr> <tr><td>8</td><td>3/16</td><td>3/32</td></tr> <tr><td>X</td><td>Solenoid Only</td><td></td></tr> </tbody> </table> Select X when Kit Type is 1. Select 0, 1, 3, 4, 6, 7, 8 when Kit Type is 2 or 3.	Body	Stop	Only Available with Valve Type	0	1/32	1/32	1	3/64	3/64	1	3/64	1/16	3	1/8	1/16	3	1/16	1/16	4	1/8	3/32	4	3/32	3/32	6	1/8	3/32	7	5/32	3/32	8	3/16	3/32	X	Solenoid Only		<b>Seals</b> 1 Buna N X Solenoid Only Select X when Kit Type is 1. Select 1 when Kit Type is 2 or 3.	<b>Coil Class</b> <table border="1"> <thead> <tr> <th>Class</th> <th>Hertz</th> </tr> </thead> <tbody> <tr><td>1</td><td>F 60</td></tr> <tr><td>2</td><td>F DC</td></tr> <tr><td>X</td><td>Plunger &amp; Stop Assy Only</td></tr> </tbody> </table> Select X when Kit Type is 2. Select the other Options when Kit Type is 1 or 3.	Class	Hertz	1	F 60	2	F DC	X	Plunger & Stop Assy Only	<b>Voltage</b> 2* 12 3 24 5** 120 (110) 6** 240 (220) X Plunger & Stop Assy Only * Not available with Coil Class 1. ** Not available with Coil Class 2. Select X when Kit Type is 2. Select the other Options when Kit Type is 1 or 3.	
Body	Stop	Only Available with Valve Type																																																		
0	1/32	1/32																																																		
1	3/64	3/64																																																		
1	3/64	1/16																																																		
3	1/8	1/16																																																		
3	1/16	1/16																																																		
4	1/8	3/32																																																		
4	3/32	3/32																																																		
6	1/8	3/32																																																		
7	5/32	3/32																																																		
8	3/16	3/32																																																		
X	Solenoid Only																																																			
Class	Hertz																																																			
1	F 60																																																			
2	F DC																																																			
X	Plunger & Stop Assy Only																																																			

**Engineering Level "B" valves can use Kit Types: 1, 2, or 3.**  
**All other valves ONLY use Kit Type 3.**  
**Example:**  
 For Valve Model Number 765030115:  
 The Only Kit Is PS193653115P  
**Example:**  
 For Valve Model Number 765030115B:  
 The Solenoid Assy. No. Is PS1916XXX15P  
 The Plunger Stop Assy. No. Is PS192X531XXP





**Pneumatic Division**  
Richland, Michigan 49083  
269-629-5000

**PDNSG-1**

**Pneumatic Division Safety Guide**

**ISSUED: August 1, 2006**

**Supersedes: June 1, 2006**

## **Safety Guide For Selecting And Using Pneumatic Division Products And Related Accessories**

### **⚠ WARNING:**

**FAILURE OR IMPROPER SELECTION OR IMPROPER USE OF PNEUMATIC DIVISION PRODUCTS, ASSEMBLIES OR RELATED ITEMS ("PRODUCTS") CAN CAUSE DEATH, PERSONAL INJURY, AND PROPERTY DAMAGE. POSSIBLE CONSEQUENCES OF FAILURE OR IMPROPER SELECTION OR IMPROPER USE OF THESE PRODUCTS INCLUDE BUT ARE NOT LIMITED TO:**

- Unintended or mistimed cycling or motion of machine members or failure to cycle
- Work pieces or component parts being thrown off at high speeds.
- Failure of a device to function properly for example, failure to clamp or unclamp an associated item or device.
- Explosion
- Suddenly moving or falling objects.
- Release of toxic or otherwise injurious liquids or gasses.

Before selecting or using any of these Products, it is important that you read and follow the instructions below.

### **1. GENERAL INSTRUCTIONS**

- 1.1. Scope:** This safety guide is designed to cover general guidelines on the installation, use, and maintenance of Pneumatic Division Valves, FRLs (Filters, Pressure Regulators, and Lubricators), Vacuum products and related accessory components.
- 1.2. Fail-Safe:** Valves, FRLs, Vacuum products and their related components can and do fail without warning for many reasons. Design all systems and equipment in a fail-safe mode, so that failure of associated valves, FRLs or Vacuum products will not endanger persons or property.
- 1.3. Relevant International Standards:** For a good guide to the application of a broad spectrum of pneumatic fluid power devices see: ISO 4414:1998, Pneumatic Fluid Power – General Rules Relating to Systems. See [www.iso.org](http://www.iso.org) for ordering information.
- 1.4. Distribution:** Provide a copy of this safety guide to each person that is responsible for selection, installation, or use of Valves, FRLs or Vacuum products. Do not select, or use Parker valves, FRLs or vacuum products without thoroughly reading and understanding this safety guide as well as the specific Parker publications for the products considered or selected.
- 1.5. User Responsibility:** Due to the wide variety of operating conditions and applications for valves, FRLs, and vacuum products Parker and its distributors do not represent or warrant that any particular valve, FRL or vacuum product is suitable for any specific end use system. This safety guide does not analyze all technical parameters that must be considered in selecting a product. The user, through its own analysis and testing, is solely responsible for:
  - Making the final selection of the appropriate valve, FRL, Vacuum component, or accessory.
  - Assuring that all user's performance, endurance, maintenance, safety, and warning requirements are met and that the application presents no health or safety hazards.
  - Complying with all existing warning labels and / or providing all appropriate health and safety warnings on the equipment on which the valves, FRLs or Vacuum products are used; and,
  - Assuring compliance with all applicable government and industry standards.
- 1.6. Safety Devices:** Safety devices should not be removed, or defeated.
- 1.7. Warning Labels:** Warning labels should not be removed, painted over or otherwise obscured.
- 1.8. Additional Questions:** Call the appropriate Parker technical service department if you have any questions or require any additional information. See the Parker publication for the product being considered or used, or call 1-800-CPARKER, or go to [www.parker.com](http://www.parker.com), for telephone numbers of the appropriate technical service department.

### **2. PRODUCT SELECTION INSTRUCTIONS**

- 2.1. Flow Rate:** The flow rate requirements of a system are frequently the primary consideration when designing any pneumatic system. System components need to be able to provide adequate flow and pressure for the desired application.
- 2.2. Pressure Rating:** Never exceed the rated pressure of a product. Consult product labeling, Pneumatic Division catalogs or the instruction sheets supplied for maximum pressure ratings.
- 2.3. Temperature Rating:** Never exceed the temperature rating of a product. Excessive heat can shorten the life expectancy of a product and result in complete product failure.
- 2.4. Environment:** Many environmental conditions can affect the integrity and suitability of a product for a given application. Pneumatic Division products are designed for use in general purpose industrial applications. If these products are to be used in unusual circumstances such as direct sunlight and/or corrosive or caustic environments, such use can shorten the useful life and lead to premature failure of a product.
- 2.5. Lubrication and Compressor Carryover:** Some modern synthetic oils can and will attack nitrile seals. If there is any possibility of synthetic oils or greases migrating into the pneumatic components check for compatibility with the seal materials used. Consult the factory or product literature for materials of construction.
- 2.6. Polycarbonate Bowls and Sight Glasses:** To avoid potential polycarbonate bowl failures:
  - Do not locate polycarbonate bowls or sight glasses in areas where they could be subject to direct sunlight, impact blow, or temperatures outside of the rated range.
  - Do not expose or clean polycarbonate bowls with detergents, chlorinated hydro-carbons, ketones, esters or certain alcohols.
  - Do not use polycarbonate bowls or sight glasses in air systems where compressors are lubricated with fire resistant fluids such as phosphate ester and di-ester lubricants.

## Pneumatic Division Safety Guide

- 2.7. Chemical Compatibility:** For more information on plastic component chemical compatibility see Pneumatic Division technical bulletins Tec-3, Tec-4, and Tec-5
- 2.8. Product Rupture:** Product rupture can cause death, serious personal injury, and property damage.
- Do not connect pressure regulators or other Pneumatic Division products to bottled gas cylinders.
  - Do not exceed the maximum primary pressure rating of any pressure regulator or any system component.
  - Consult product labeling or product literature for pressure rating limitations.

### 3. PRODUCT ASSEMBLY AND INSTALLATION INSTRUCTIONS

- 3.1. Component Inspection:** Prior to assembly or installation a careful examination of the valves, FRLs or vacuum products must be performed. All components must be checked for correct style, size, and catalog number. DO NOT use any component that displays any signs of nonconformance.
- 3.2. Installation Instructions:** Parker published Installation Instructions must be followed for installation of Parker valves, FRLs and vacuum components. These instructions are provided with every Parker valve or FRL sold, or by calling 1-800-CPARKER, or at [www.parker.com](http://www.parker.com).
- 3.3. Air Supply:** The air supply or control medium supplied to Valves, FRLs and Vacuum components must be moisture-free if ambient temperature can drop below freezing

### 4. VALVE AND FRL MAINTENANCE AND REPLACEMENT INSTRUCTIONS

- 4.1. Maintenance:** Even with proper selection and installation, valve, FRL and vacuum products service life may be significantly reduced without a continuing maintenance program. The severity of the application, risk potential from a component failure, and experience with any known failures in the application or in similar applications should determine the frequency of inspections and the servicing or replacement of Pneumatic Division products so that products are replaced before any failure occurs. A maintenance program must be established and followed by the user and, at minimum, must include instructions 4.2 through 4.10.
- 4.2. Installation and Service Instructions:** Before attempting to service or replace any worn or damaged parts consult the appropriate Service Bulletin for the valve or FRL in question for the appropriate practices to service the unit in question. These Service and Installation Instructions are provided with every Parker valve and FRL sold, or are available by calling 1-800-CPARKER, or by accessing the Parker web site at [www.parker.com](http://www.parker.com).
- 4.3. Lockout / Tagout Procedures:** Be sure to follow all required lockout and tagout procedures when servicing equipment. For more information see: OSHA Standard – 29 CFR, Part 1910.147, Appendix A, The Control of Hazardous Energy – (Lockout / Tagout)
- 4.4. Visual Inspection:** Any of the following conditions requires immediate system shut down and replacement of worn or damaged components:
- Air leakage: Look and listen to see if there are any signs of visual damage to any of the components in the system. Leakage is an indication of worn or damaged components.
  - Damaged or degraded components: Look to see if there are any visible signs of wear or component degradation.
  - Kinked, crushed, or damaged hoses. Kinked hoses can result in restricted air flow and lead to unpredictable system behavior.
  - Any observed improper system or component function: Immediately shut down the system and correct malfunction.
  - Excessive dirt build-up: Dirt and clutter can mask potentially hazardous situations.
- Caution: Leak detection solutions should be rinsed off after use.**
- 4.5. Routine Maintenance Issues:**
- Remove excessive dirt, grime and clutter from work areas.
  - Make sure all required guards and shields are in place.
- 4.6. Functional Test:** Before initiating automatic operation, operate the system manually to make sure all required functions operate properly and safely.
- 4.7. Service or Replacement Intervals:** It is the user's responsibility to establish appropriate service intervals. Valves, FRLs and vacuum products contain components that age, harden, wear, and otherwise deteriorate over time. Environmental conditions can significantly accelerate this process. Valves, FRLs and vacuum components need to be serviced or replaced on routine intervals. Service intervals need to be established based on:
- Previous performance experiences.
  - Government and / or industrial standards.
  - When failures could result in unacceptable down time, equipment damage or personal injury risk.
- 4.8. Servicing or Replacing of any Worn or Damaged Parts:** To avoid unpredictable system behavior that can cause death, personal injury and property damage:
- Follow all government, state and local safety and servicing practices prior to service including but not limited to all OSHA Lockout Tagout procedures (OSHA Standard – 29 CFR, Part 1910.147, Appendix A, The Control of Hazardous Energy – Lockout / Tagout).
  - Disconnect electrical supply (when necessary) before installation, servicing, or conversion.
  - Disconnect air supply and depressurize all air lines connected to system and Pneumatic Division products before installation, service, or conversion.
  - Installation, servicing, and / or conversion of these products must be performed by knowledgeable personnel who understand how pneumatic products are to be applied.
  - After installation, servicing, or conversions air and electrical supplies (when necessary) should be connected and the product tested for proper function and leakage. If audible leakage is present, or if the product does not operate properly, do not put product or system into use.
  - Warnings and specifications on the product should not be covered or painted over. If masking is not possible, contact your local representative for replacement labels.
- 4.9. Putting Serviced System Back into Operation:** Follow the guidelines above and all relevant Installation and Maintenance Instructions supplied with the valve FRL or vacuum component to insure proper function of the system.