

Pneumatic Division

Richland, Michigan USA

www.parker.com/pneumatics



SPEEDKING - 1/2 INCH

Bulletin Number		Bulletin Description
<input type="checkbox"/>	V539P	L-Pilot Valve, Installation & Service Instructions
<input type="checkbox"/>	V543P	Subbase & Manifolds, Installation Instructions
<input type="checkbox"/>	V550P Rev. 6	1/2" SK200 Single Operated Valve, Installation Instructions
<input type="checkbox"/>	V551P Rev. 6	1/2" SK200 2-Position Double Operated Valve, Installation Instructions
<input type="checkbox"/>	V552P Rev. 6	1/2" SK200 3-Position Double Operated Valve, Installation Instructions
<input type="checkbox"/>	V553P Rev. 3	1/2" SK200 Single Operated Valve, Installation & Service Instructions
<input type="checkbox"/>	V554P Rev. 3	1/2" SK200 2-Position Double Operated Valve, Installation & Service Instructions
<input type="checkbox"/>	V555P Rev. 3	1/2" SK200 3-Position Double Operated Valve, Installation & Service Instructions
<input type="checkbox"/>	V556P Rev. 7	1/2" SK200 Single Poppet Valve, Installation Instructions
<input type="checkbox"/>	V557P	1/2" SK200 Single Solenoid Poppet Valve, Service Instructions
<input type="checkbox"/>	V664P	L-Pilot & Operators, Installation & Service Instructions
<input type="checkbox"/>	V648P	Time Delap Modules - K705 Series, Installation Instructions
<input type="checkbox"/>	Safety Guide	PDN Safety Guide



Pneumatic Division
 Richland, Michigan 49083

Installation & Service Instructions
V539P

L-Pilot Series Valves

ISSUED: June, 2003

Supersedes: None

Doc.# V-539P, ECN030466

WARNING

To avoid unpredictable system behavior that can cause personal injury and property damage:

- Disconnect electrical supply (when necessary) before installation, servicing, or conversion.
- Disconnect air supply and depressurize all air lines connected to this product before installation, servicing, or conversion.
- Operate within the manufacturer's specified pressure, temperature, and other conditions listed in these instructions.
- Medium must be moisture-free if ambient temperature is below freezing.
- Service according to procedures listed in these instructions.
- Installation, service, and conversion of these products must be performed by knowledgeable personnel who understand how pneumatic products are to be applied.
- After installation, servicing, or conversion, air and electrical supplies (when necessary) should be connected and the product tested for proper function and leakage. If audible leakage is present, or the product does not operate properly, do not put into use.
- Warnings and specifications on the product should not be covered by paint, etc. If masking is not possible, contact your local representative for replacement labels.

Introduction

Follow these instructions when installing, operating, or servicing the product.

Service Kit O-Rings

Service Kits **K352166** and **K352366** will now have both the Small and Large O-ring. Use the one that is appropriate for your product and discard the other.

Top Seat O-rings supplied in this Service Kit:

As of September 2002 (Date Code 3702), the following series of Pilot Valves (Standard Service) have the Large O-ring.

K015	K175
K025	K185
K055	K225
K065	K235

As of June 2003 (Date Code 2503), the following series of Pilot Valves (Special Service) will have the Smaller O-ring.

K035	K085
K045	K245
K075	K255

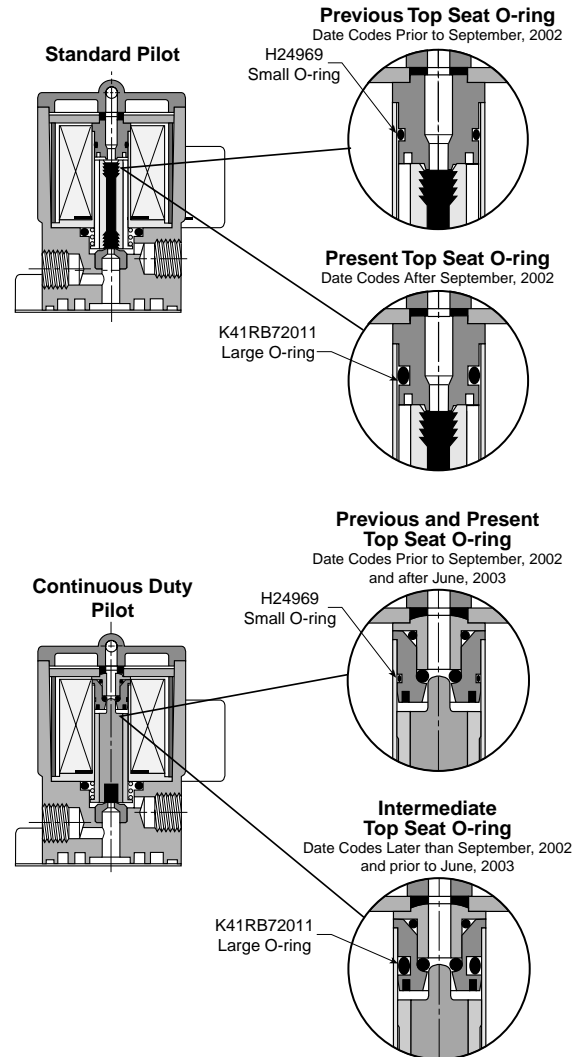

WARNING

FAILURE OR IMPROPER SELECTION OR IMPROPER USE OF THE PRODUCTS AND/OR SYSTEMS DESCRIBED HEREIN OR RELATED ITEMS CAN CAUSE DEATH, PERSONAL INJURY AND PROPERTY DAMAGE.

This document and other information from Parker Hannifin Corporation, its subsidiaries and authorized distributors provide product and/or system options for further investigation by users having technical expertise. It is important that you analyze all aspects of your application, including consequences of any failure and review the information concerning the product or systems in the current product catalog. Due to the variety of operating conditions and applications for these products or systems, the user, through its own analysis and testing, is solely responsible for making the final selection of the products and systems and assuring that all performance, safety and warning requirements of the application are met.

The products described herein, including without limitation, product features, specifications, designs, availability and pricing, are subject to change by Parker Hannifin Corporation and its subsidiaries at any time without notice.

EXTRA COPIES OF THESE INSTRUCTIONS ARE AVAILABLE FOR INCLUSION IN EQUIPMENT / MAINTENANCE MANUALS THAT UTILIZE THESE PRODUCTS. CONTACT YOUR LOCAL REPRESENTATIVE.



WARNING

To avoid unpredictable system behavior that can cause personal injury and property damage:

- Disconnect air supply and depressurize all air lines connected to this product before installation, servicing, or conversion.
- Disconnect electrical supply before installation, servicing or conversion.
- Operate within the manufacturer's specified pressure, temperature, voltage and other conditions listed in these instructions.
- Medium must be moisture-free if ambient temperature is below freezing.
- Service according to procedures listed on service instruction sheets.
- Installation, service and conversion of these products must be performed by knowledgeable personnel who understand how pneumatic products are to be applied.
- After installation, servicing, or conversion, air and electrical supplies should be connected and the product tested for proper function and leakage. If audible leakage is present, or the product does not operate properly, do not put into use.
- Warnings and specifications on the product should not be covered by paint, etc. If masking is not possible, contact your local representative for replacement labels.

APPLICATION LIMITS

These products are intended for use in general purpose compressed air systems only. Compliance with the rated pressure, temperature and voltage is necessary – see installation instructions packed with (or label on) valve.

WIRING INSTRUCTIONS

Single Solenoid: Use wires marked "2" and "3" for connection to the solenoid. For units with DC solenoids and indicator lights or arc suppression coils, wire marked "3" is positive.

Double Solenoid: Use wires marked "1" and "2" for Solenoid "A". Use wires marked "3" and "4" for Solenoid "B". For units with DC solenoids and indicator lights or arc suppression coils, wires marked "1" and "3" are positive.



CAUTION: DC solenoids with indicator lights and/or arc suppression coils are polarity sensitive. Observe polarities indicated above.

Earth ground: All electrically operated valves must be provided a proper earth ground. Remove the end cover of the manifold or subbase and connect a ground lead to the green ground screw.

NOTE: In addition to the above instructions, follow all requirements for local and national electrical codes.

VALVE MOUNTING PROCEDURES

(Applies to both subbases and manifolds)

- 1) Clean top surface of subbase or manifold and bottom surface of valve body of any dirt or dust.
- 2) Position gasket on top of subbase or manifold, lining up all four mounting holes.

VALVE MOUNTING PROCEDURES –CONTINUED

- 3) Place valve on top of gasket, lining up all four mounting holes. Electrically operated valves also require pressing down on valve to seat electrical plug.
- 3) Insert (4) valve mounting screws and torque to 80-90 in.-lbs in progressive steps with a crisscross pattern.

SUBBASE PORT CONNECTIONS

(See reverse for Manifold Port Connections)

- 1) Connect a single inlet air supply to port "P". (For dual pressure applications, connect inlet air supplies to ports "EA" and "EB".)
- 2) Connect mufflers (or plumb exhaust) from ports "EA" and "EB" for single air supply. (For dual pressure applications, connect to port "P".)
- 3) Connect cylinder ports "A" and "B" to ends of cylinder or other device to be supplied air.

SUBBASE EXTERNAL PILOT SUPPLY CONNECTION

(See reverse for Manifold External Pilot Supply Connections.)

Use an external pilot for dual inlet air supplies, for inlet pressures below minimum valve ratings, or any other application requiring pilot pressure different than main supply pressure.

- 1) Perform pilot supply conversion outlined on Installation Instructions packed with valve.
- 2) Connect pilot supply source to port "X".

3/8" Subbase

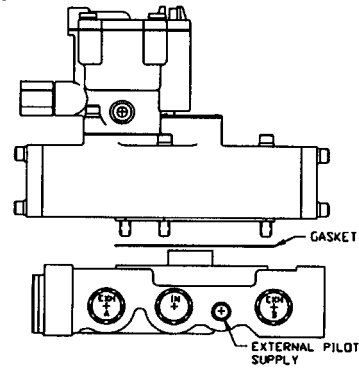

1/2" Subbase

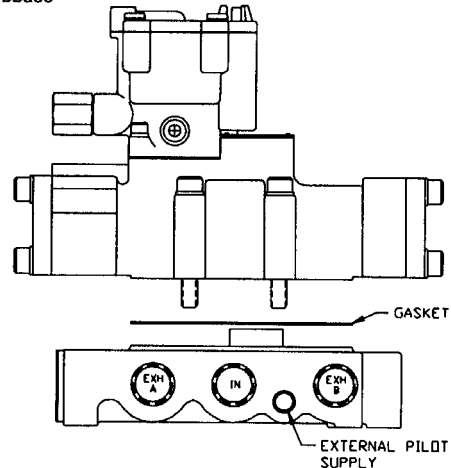

MANIFOLD APPLICATION

Valves may be gang manifolded up to any number of stations, providing that sufficient pressure is realized in the circuits down-stream of the valve outlets; and sufficient pressure is available for shifting the valves. Longer manifold gangs may require intermediate supports. Means to increase pressure levels include supply connections at both ends of the manifold gang, external pilot supplies and sequencing the valve operation to maximize time between different valve shifts.

CAUTION: Air exhausting from one valve into the exhaust gallery of the manifold may pressurize other valve circuits open to the same gallery. Design the circuit such that there is no hazard or damage consequence from this action.

MANIFOLD ASSEMBLY PROCEDURES

Manifolds may be assembled to one another either before or after assembling valves to manifolds. Inlet, exhaust or external pilot galleries are to be isolated from neighboring manifolds, be sure to follow **Manifold Isolation Procedures** before proceeding with this section.

- 1) If wiring is to be done in manifold junction boxes, rather than in an external junction box, loosen electrical cover mounting screws on end of manifolds, remove covers and pull wires out through cover openings.
- 2) Clean counterbores inside of manifold and mating surface of neighboring manifold.
- 3) Apply light coating of grease (in kit) to o-rings and place in counterbores.
- 4) Place manifold next to neighboring manifold. If wiring is to be done in an external junction box, pull wires through conduit gallery of neighboring manifold.
- 5) Insert hex head screws through clearance holes in one manifold and screw into neighboring manifold. Torque screws to 160-180 in.-lbs.
- 6) Connect a grounding wire to the green ground screw of a least one manifold and feed this wire through conduit gallery to either end of manifold.
- 7) Replace electrical covers and tighten cover screws.

MANIFOLD PORT CONNECTIONS

(See front for Subbase Port Connections)

- 1) Connect inlet air supply to manifold inlet gallery by one of the following methods:
All valves to be supplied with a common pressure: Connect air supply to port "P" on either end of manifold package and plug other end port "P" (or connect air supply to both ends for applications requiring a larger volume of air).
Two groups of valves each requiring a different pressure: Isolate valves into two groups using **Manifold Isolation Procedures**. Connect appropriate air supply to each end of manifold bank at port "P".
- 2) Connect mufflers (or plumb exhaust) at "E" ports.
- 3) Connect cylinder ports "A" and "B" to ends of cylinder or other device to be supplied air. Connections are commonly made to ports on end of manifold opposite wiring cavity. If bottom ports are more accessible to your application, plug end cylinder ports and remove plugs from bottom ports.

MANIFOLD EXTERNAL PILOT CONNECTIONS

(See front for Subbase External Pilot Supply Connections)

Use an external pilot for dual inlet air supplies, for inlet pressures below minimum valve ratings, or any other application requiring pilot pressure different than main supply pressure.

- 1) Perform pilot supply conversion outlined on Installation Instructions packed with valve.
- 2) Isolate external pilot supply gallery (designated by "X") to those valves requiring external pilot supply.
- 3) Connect pilot supply to the "X" port gallery, or to those stations requiring external pilot supply, at their alternate "X" port connection. Plug all open "X" ports.

MANIFOLD ISOLATION PROCEDURES

Inlet, exhaust and external pilot galleries may be isolated from those in neighboring manifolds through the use of flush pipe plugs.

- 1) Determine gallery and manifold position to be isolated.
- 2) Apply pipe sealant to threads of pipe plug.
- 3) Screw pipe plug into threaded end of gallery and tighten.

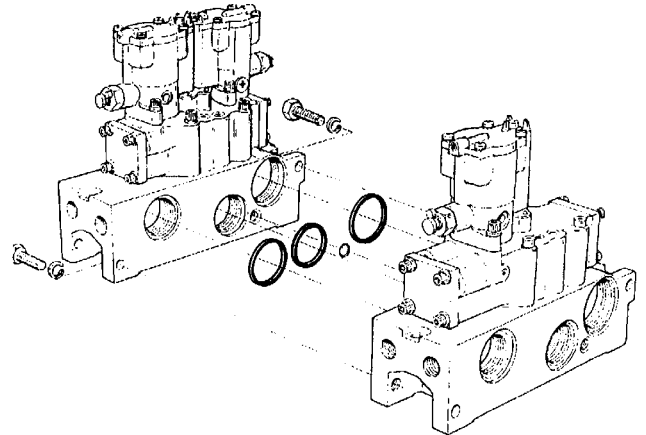
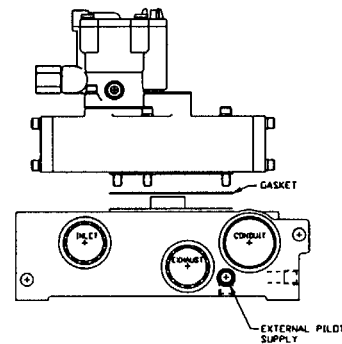

WARNING

FAILURE OR IMPROPER SELECTION OR IMPROPER USE OF THE PRODUCTS AND/OR SYSTEMS DESCRIBED HEREIN OR RELATED ITEMS CAN CAUSE DEATH, PERSONAL INJURY AND PROPERTY DAMAGE.

This document and other information from Parker Hannifin Corporation, its subsidiaries and authorized distributors provide product and/or system options for further investigation by users having technical expertise. It is important that you analyze all aspects of your application, including consequences of any failure, and review the information concerning the product or system in the current product catalog. Due to the variety of operating conditions and applications for these products or systems, the user, through its own analysis and testing, is solely responsible for making the final selection of the products and systems and assuring that all performance, safety and warning requirements of the application are met.

The products described herein, including without limitation, product features, specifications, designs, availability and pricing, are subject to change by Parker Hannifin Corporation and its subsidiaries at any time without notice.

EXTRA COPIES OF THESE INSTRUCTIONS ARE AVAILABLE FOR INCLUSION IN EQUIPMENT / MAINTENANCE INSTRUCTION MANUALS THAT UTILIZE THESE PRODUCTS. CONTACT YOUR LOCAL REPRESENTATIVE.



Pneumatic Division North America
 Richland, MI 49083

Installation Instructions: V-550P
 1/2" SK-200/A5 Single Operated Valves
 ISSUED: May, 2001
 Supersedes: November, 1998
 ECN #9369 Rev. 6

⚠ WARNING

To avoid unpredictable system behavior that can cause personal injury and property damage:

- Disconnect air supply and depressurize all air lines connected to this product before installation, servicing, or conversion.
- Disconnect electrical supply before installation, servicing or conversion.
- Operate within the manufacturer's specified pressure, temperature, voltage and other conditions listed in these instructions.
- Medium must be moisture-free if ambient temperature is below freezing.
- Service according to procedures listed on these instructions.
- Installation, service and conversion of these products must be performed by knowledgeable personnel who understand how pneumatic products are to be applied.
- After installation, servicing, or conversion, air and electrical supplies should be connected and the product tested for proper function and leakage. If audible leakage is present, or the product does not operate properly, do not put into use.
- Warnings and specifications on the product should not be covered by paint, etc. If masking is not possible, contact your local representative for replacement labels.

INSTALLATION / OPERATING INSTRUCTIONS

Valve should be installed with reasonable accessibility for service whenever possible -- repair service kits are available. Keep pipe or tubing lengths to a minimum with inside clean and free of dirt and chips. Pipe joint compound should be used sparingly and applied only to the male pipe -- never into the female port. Do not use PTFE tape to seal pipe joints -- pieces have a tendency to break off and lodge inside the unit, possibly causing malfunction. Mounting bolt torque 80-90 in-lb. for manifold and subbase mounting valves.

Air applied to the valve must be filtered to realize maximum component life.

Life Expectancy - Normal multi-million cycle life expectancy of these valves is based on the use of properly filtered and lubricated air at room temperature. However, these valves contain o-rings specially compounded with 12% molybdenum disulfide to assure long wear in applications where air line lubrication is undesirable.

Factory Pre-Lubrication - Valves are pre-lubricated at assembly with Sunplex 781 or equivalent (Petroleum Base - Lithium Content) grease. Valves specified for vacuum service are lubricated with Dow Corning Valve Seal A.

In-Service Lubrication - F442 oil is recommended for in-service lubrication. This oil is specially formulated to provide peak performance and maximum service life from all air operated equipment. Otherwise, use an air line lubricant (compatible with Nitrile & Polyurethane seals) which will readily atomize and be of the medium aniline type. Aniline point range must be between 180° and 220° F. Viscosity at 100° F: 140 - 170 SUS.

⚠ CAUTION: Do not use synthetic, reconstituted, or oils with an alcohol content or detergent additive.

Remote Pilot Operated Valves - Connect a 3-way normally open valve to the pilot signal port for normal valve logic (P → A, B → EB). Use of a 3-way normally closed pilot valve results in reverse logic (P → B; A → EA).

Override Operation - To operate override push and turn to a full stop (at least 90°).

APPLICATION LIMITS

These products are intended for use in general purpose compressed air systems only.

Pressure Range for Solenoid Operated Valves

Media	Solenoid Pilot Supply Source						
	Internal Pilot Supply			External Pilot Supply			
	PSIG	BAR	kPa	PSIG	BAR	kPa	
Air	Valve Inlet			Valve Inlet			
	Minimum	35	2.41	241	0	0	0
	Maximum	140*	9.65	965	250*	17.24	1724
	Pilot Supply Port			Pilot Supply Port			
	PLUGGED			Minimum 35 2.41 241			
				Maximum 140* 9.65 965			
Vacuum	DO NOT USE			Valve Inlet			
				Within 1" Hg of Perfect			
				Pilot Supply Port			
				Minimum 35 2.41 241			
				Maximum 140* 9.65 965			

* Unless valve is equipped with 200 PSIG pilot valve (9th digit of model number is a "3", i.e. L5455810353 SK-200 Series only).

Pressure Range for Remote Pilot Operated Valves

Media	PSIG BAR kPa			PSIG BAR kPa				
	Valve Inlet	Remote Pilot Signal						
Air	Minimum	35	2.41	241	Minimum	35	2.41	241
	Maximum	250	17.24	1724	Maximum	200	13.79	1379
	DO NOT USE							

Operating Temperature Range:

Operator Type	Duty Cycle	Minimum Ambient Temperature	Maximum Ambient Temperature
Standard Service Solenoid	Intermittent	0°F (-18°C)	125°F (52°C)
	Continuous	0°F (-18°C)	100°F (38°C)
Special Service Solenoid	Intermittent	0°F (-18°C)	125°F (52°C)
	Continuous	0°F (-18°C)	125°F (52°C)
Remote Pilot	Not Applicable	0°F (-18°C)	200°F (93°C)

Voltage Range: +10% to -15% of rating

WIRING INSTRUCTIONS

Units with flying leads

Either wire may be "Hot".

⚠ CAUTION: DC solenoids with indicator lights and/or arc suppression coils are polarity sensitive. Use red wire as positive.

Units with plug-in subbases or manifolds

Use wires marked "2" and "3" for connection to the solenoid. Either may be "Hot".

⚠ CAUTION: DC solenoids with indicator lights and/or arc suppression coils are polarity sensitive. Use wire number 3 for single solenoid valves as positive.

⚠ CAUTION: An interruption of 10 milliseconds or greater to the power supplied to the solenoid of a solenoid operated valve may cause the valve to shift. Provision must be made to prevent power interruption of this duration to avoid unintended, potentially hazardous, consequences.

Earth ground: All electrically operated valves must be provided a proper earth ground. Connect to green wire from valve.

NOTE: In addition to the above instructions, follow all requirements for local and national electrical codes.

ANSI SYMBOLS

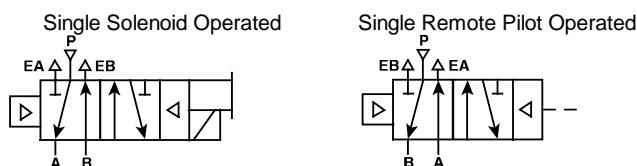

INSTALLATION

Manifold and Subbase Mounted

See *Installation Instructions V-543P 3/8" & 1/2" Series Subbases and Manifolds* packed with subbases and manifolds.

Direct Pipe Ported Valves

PORT CONNECTIONS

- 1) Connect a single inlet air supply to port "P". (For dual pressure applications, connect inlet air supplies to ports "EA" and "EB".)
- 2) Connect mufflers (or plumb exhaust) from ports "EA" and "EB" for single air supply. (For dual pressure applications, connect to port "P".)
- 3) Connect cylinder ports "A" and "B" to ends of cylinder or other device to be supplied air.

EXTERNAL PILOT SUPPLY CONNECTION

Use an external pilot for dual inlet air supplies, for inlet pressures below minimum valve ratings, or any other application requiring pilot pressure different than main supply pressure.

- 1) Perform **Conversion Procedure for External Pilot**.
- 2) Connect pilot supply source to port "X".

CONVERSION PROCEDURE FOR EXTERNAL PILOT

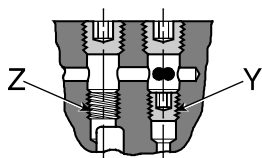

Base Mounted

For field conversion to external pilot supply, remove (2) 1/8" pipe plugs from top of valve body and move bottom plug from "Y" to "Z". Replace 1/8" pipe plugs and connect pilot pressure to the 1/4" pipe external pilot supply port "X" in subbase or manifold.

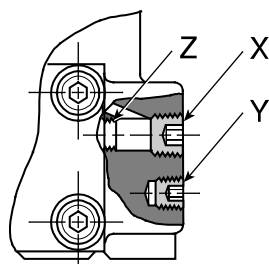

Direct Pipe Ported

For field conversion to external pilot supply, remove and discard 1/4" pipe plug in external pilot supply port "X". Move stored plug "Y" to location "Z" in bottom of pilot supply port "X". Then connect pilot pressure to port "X" in valve body.

SERVICE KITS / PARTS

Service Kit (Single Solenoid - Standard Service)	K352152
Service Kit (Single Solenoid - Special Service)	K352352
Service Kit (Single Remote Pilot Operated)	K352361
Pilot Valve / Remote Pilot Gasket	K183001
Body to Base Gasket	K183030
Indicator Light (24VDC - Line Mounting)	H19110
Indicator Light (24VDC - Base Mounting)	H19112
Indicator Light (120V / 60 HZ - Line Mounting)	H19102
Indicator Light (120V / 60 HZ - Base Mounting)	H19105

Direct Pipe Ported Valves

Voltage			Coil	
60 Hz	50 Hz	D. C.	19" Leads	72" Leads
12	--	--	K593007	K593178
24	--	6	K593003	K593179
--	24	--	K593015	K593181
--	36	--	K593016	K593183
--	--	12	K593010	K593182
--	--	24 (Standard)	K593014	K593184
--	--	24 (Arc Suppressed)	K593271	K593272
--	--	48	K593028	K593185
120	110	--	K593025	K593186
240	220	--	K593035	K593187
--	240	--	K593033	K593188
--	--	90	K593020	K593189
--	--	115	K593041	K593190
--	380	--	K593038	K593191

Base Mounting Valves

Voltage			Coil	
60 Hz	50 Hz	D. C.	No Light	With Light
12	--	--	K593052	--
24	--	6	K593048	--
--	24	--	K593061	--
--	36	--	K593062	--
--	--	12	K593055	--
--	--	24 (Standard)	K593060	K593274
--	--	24 (Arc Suppressed)	K593305	K593275
--	--	48	K593074	--
120	110	--	K593071	K593125
240	220	--	K593081	--
--	240	--	K593079	--

WARNING

FAILURE OR IMPROPER SELECTION OR IMPROPER USE OF THE PRODUCTS AND/OR SYSTEMS DESCRIBED HEREIN OR RELATED ITEMS CAN CAUSE DEATH, PERSONAL INJURY AND PROPERTY DAMAGE.

This document and other information from Parker Hannifin Corporation, its subsidiaries and authorized distributors provide product and/or system options for further investigation by users having technical expertise. It is important that you analyze all aspects of your application, including consequences of any failure, and review the information concerning the product or system in the current product catalog. Due to the variety of operating conditions and applications for these products or systems, the user, through its own analysis and testing, is solely responsible for making the final selection of the products and systems and assuring that all performance, safety and warning requirements of the application are met.

The products described herein, including without limitation, product features, specifications, designs, availability and pricing, are subject to change by Parker Hannifin Corporation and its subsidiaries at any time without notice.

EXTRA COPIES OF THESE INSTRUCTIONS ARE AVAILABLE FOR INCLUSION IN EQUIPMENT / MAINTENANCE INSTRUCTION MANUALS THAT UTILIZE THESE PRODUCTS. CONTACT YOUR LOCAL REPRESENTATIVE.



Pneumatic Division North America
8676 East M-89
Richland, MI 49083

Installation Instructions: V-551P

1/2" SK-200/A5 Double Operated Valves
2-Position

ISSUED: May, 2001

Supersedes: November, 1998

ECN #9369 Rev. 6

⚠ WARNING

To avoid unpredictable system behavior that can cause personal injury and property damage:

- Disconnect air supply and depressurize all air lines connected to this product before installation, servicing, or conversion.
- Disconnect electrical supply before installation, servicing or conversion.
- Operate within the manufacturer's specified pressure, temperature, voltage and other conditions listed in these instructions.
- Medium must be moisture-free if ambient temperature is below freezing.
- Service according to procedures listed on these instructions.
- Installation, service and conversion of these products must be performed by knowledgeable personnel who understand how pneumatic products are to be applied.
- After installation, servicing, or conversion, air and electrical supplies should be connected and the product tested for proper function and leakage. If audible leakage is present, or the product does not operate properly, do not put into use.
- Warnings and specifications on the product should not be covered by paint, etc. If masking is not possible, contact your local representative for replacement labels.

INSTALLATION / OPERATING INSTRUCTIONS

Valve should be installed with reasonable accessibility for service whenever possible -- repair service kits are available. Keep pipe or tubing lengths to a minimum with inside clean and free of dirt and chips. Pipe joint compound should be used sparingly and applied only to the male pipe -- never into the female port. Do not use PTFE tape to seal pipe joints -- pieces have a tendency to break off and lodge inside the unit, possibly causing malfunction. Mounting bolt torque 80-90 in-lb. for manifold and subbase mounting valves.

⚠ CAUTION: Mount the valve so that the main valve spool is horizontal. When the valve is depressurized the spool could shift due to the effects of gravity and/or vibration.

Air applied to the valve must be filtered to realize maximum component life.

Life Expectancy - Normal multi-million cycle life expectancy of these valves is based on the use of properly filtered and lubricated air at room temperature. However, these valves contain o-rings specially compounded with 12% molybdenum disulfide to assure long wear in applications where air line lubrication is undesirable.

Factory Pre-Lubrication - Valves are pre-lubricated at assembly with Sunaplex 781 or equivalent (Petroleum Base - Lithium Content) grease. Valves specified for vacuum service are lubricated with Dow Corning Valve Seal A.

In-Service Lubrication - F442 oil is recommended for in-service lubrication. This oil is specially formulated to provide peak performance and maximum service life from all air operated equipment. Otherwise, use an air line lubricant (compatible with Nitrile & Polyurethane seals) which will readily atomize and be of the medium aniline type. Aniline point range must be between 180° and 220° F. Viscosity at 100° F: 140 - 170 SUS.

⚠ CAUTION: Do not use synthetic, reconstituted, or oils with an alcohol content or detergent additive.

Override Operation - To operate override push and turn to a full stop (at least 90°).

APPLICATION LIMITS

These products are intended for use in general purpose compressed air systems only.

Pressure Range for Solenoid Operated Valves

Media	Solenoid Pilot Supply Source					
	Internal Pilot Supply			External Pilot Supply		
	PSIG	BAR	kPa	PSIG	BAR	kPa
Air	Valve Inlet			Valve Inlet		
	Minimum	35	2.41	241	Minimum	0 0 0
	Maximum	140*	9.65	965	Maximum	250* 17.24 1724
	Pilot Supply Port			Pilot Supply Port		
	PLUGGED			Minimum 35 2.41 241		
				Maximum 140* 9.65 965		
Vacuum	DO NOT USE			Valve Inlet		
				Within 1" Hg of Perfect		
				Pilot Supply Port		
				Minimum 35 2.41 241		
				Maximum 140* 9.65 965		

* Unless valve is equipped with 200 PSIG pilot valve (9th digit of model number is a "3", i.e. L5155810353 SK-200 Series only).

Pressure Range for Remote Pilot Operated Valves

Media	PSIG BAR kPa			PSIG BAR kPa		
	Air	Valve Inlet			Remote Pilot Signal	
Minimum		0 0 0	0	Minimum	35 2.41 241	
Maximum		250 17.24 1724		Maximum	200 13.79 1379	
Vacuum	Valve Inlet			Remote Pilot Signal		
	Within 1" Hg of Perfect			Minimum 35 2.41 241		
				Maximum 200 13.79 1379		

Operating Temperature Range:

Operator Type	Duty Cycle	Minimum Ambient Temperature	Maximum Ambient Temperature
Standard Service Solenoid	Intermittent	0°F (-18°C)	125°F (52°C)
	Continuous	0°F (-18°C)	100°F (38°C)
Special Service Solenoid	Intermittent	0°F (-18°C)	125°F (52°C)
	Continuous	0°F (-18°C)	125°F (52°C)
Remote Pilot	Not Applicable	0°F (-18°C)	200°F (93°C)

Voltage Range: +10% to -15% of rating

WIRING INSTRUCTIONS

Units with flying leads

Either wire may be "Hot".

⚠ CAUTION: DC solenoids with indicator lights and/or arc suppression coils are polarity sensitive. Use red wire as positive.

Units with plug-in subbases or manifolds

Use wires marked "1" and "2" for Solenoid "A". Use wires marked "3" and "4" for solenoid "B". For units with DC solenoids and indicator lights or arc suppression coils, wires marked "1" and "3" are positive.

⚠ CAUTION: DC solenoids with indicator lights or arc suppression coils are polarity sensitive. Observe polarities indicated above.

⚠ CAUTION: An interruption of 10 milliseconds or greater to the power supplied to the solenoid of a solenoid operated valve may cause the valve to shift. Provision must be made to prevent power interruption of this duration to avoid unintended, potentially hazardous, consequences.

Earth ground: All electrically operated valves must be provided a proper earth ground. Connect to green wire from valve.

NOTE: In addition to the above instructions, follow all requirements for local and national electrical codes.

ANSI SYMBOLS

Double Solenoid Operated Double Remote Pilot Operated

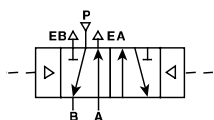
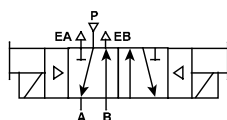

INSTALLATION

Manifold and Subbase Mounted Valves

See *Installation Instructions V-543P 3/8" & 1/2" Series Subbases and Manifolds* packed with subbases and manifolds.

Direct Pipe Ported Valves

PORT CONNECTIONS

- 1) Connect a single inlet air supply to port "P". (For dual pressure applications, connect inlet air supplies to ports "EA" and "EB".)
- 2) Connect mufflers (or plumb exhaust) from ports "EA" and "EB" for single air supply. (For dual pressure applications, connect to port "P".)
- 3) Connect cylinder ports "A" and "B" to ends of cylinder or other device to be supplied air.

EXTERNAL PILOT SUPPLY CONNECTION

Use an external pilot for dual inlet air supplies, for inlet pressures below minimum valve ratings, or any other application requiring pilot pressure different than main supply pressure.

- 1) Perform **Conversion Procedure for External Pilot**.
- 2) Connect pilot supply source to port "X".

CONVERSION PROCEDURE FOR EXTERNAL PILOT

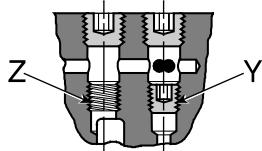

Base Mounted

For field conversion to external pilot supply, remove (2) 1/8" pipe plugs from top of valve body and move bottom plug from "Y" to "Z". Replace 1/8" pipe plugs and connect pilot pressure to the 1/4" pipe external pilot supply port "X" in subbase or manifold.

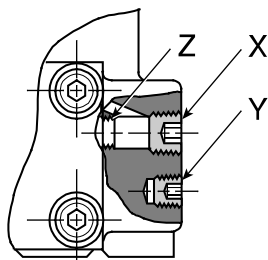

Direct Pipe Ported

For field conversion to external pilot supply, remove and discard 1/4" pipe plug in external pilot supply port "X". Move stored plug "Y" to location "Z" in bottom of pilot supply port "X". Then connect pilot pressure to port "X" in valve body.

SERVICE KITS / PARTS

Service Kit (Double Solenoid - Standard Service)	K352153
Service Kit (Double Solenoid - Special Service)	K352353
Service Kit (Double Remote Pilot Operated)	K352358
Pilot Valve / Remote Pilot Gasket	K183001
Body to Base Gasket	K183030
Indicator Light (24VDC - Line Mounting)	H19110
Indicator Light (24VDC - Base Mounting)	H19112
Indicator Light (120V / 60 HZ - Line Mounting)	H19102
Indicator Light (120V / 60 HZ - Base Mounting)	H19105

Direct Pipe Ported Valves

Voltage			Coil	
60 Hz	50 Hz	D. C.	19" Leads	72" Leads
12	--	--	K593007	K593178
24	--	6	K593003	K593179
--	24	--	K593015	K593181
--	36	--	K593016	K593183
--	--	12	K593010	K593182
--	--	24 (Standard)	K593014	K593184
--	--	24 (Arc Suppressed)	K593271	K593272
--	--	48	K593028	K593185
120	110	--	K593025	K593186
240	220	--	K593035	K593187
--	240	--	K593033	K593188
--	--	90	K593020	K593189
--	--	115	K593041	K593190
--	380	--	K593038	K593191

Base Mounting Valves

Voltage			Coil	
60 Hz	50 Hz	D. C.	No Light	With Light
12	--	--	K593052	--
24	--	6	K593048	--
--	24	--	K593061	--
--	36	--	K593062	--
--	--	12	K593055	--
--	--	24 (Standard)	K593060	K593274
--	--	24 (Arc Suppressed)	K593305	K593275
--	--	48	K593074	--
120	110	--	K593071	K593125
240	220	--	K593081	--
--	240	--	K593079	--

WARNING

FAILURE OR IMPROPER SELECTION OR IMPROPER USE OF THE PRODUCTS AND/OR SYSTEMS DESCRIBED HEREIN OR RELATED ITEMS CAN CAUSE DEATH, PERSONAL INJURY AND PROPERTY DAMAGE.

This document and other information from Parker Hannifin Corporation, its subsidiaries and authorized distributors provide product and/or system options for further investigation by users having technical expertise. It is important that you analyze all aspects of your application, including consequences of any failure, and review the information concerning the product or system in the current product catalog. Due to the variety of operating conditions and applications for these products or systems, the user, through its own analysis and testing, is solely responsible for making the final selection of the products and systems and assuring that all performance, safety and warning requirements of the application are met.

The products described herein, including without limitation, product features, specifications, designs, availability and pricing, are subject to change by Parker Hannifin Corporation and its subsidiaries at any time without notice.

EXTRA COPIES OF THESE INSTRUCTIONS ARE AVAILABLE FOR INCLUSION IN EQUIPMENT / MAINTENANCE INSTRUCTION MANUALS THAT UTILIZE THESE PRODUCTS. CONTACT YOUR LOCAL REPRESENTATIVE.



Pneumatic Division North America
Richland, MI 49083

Installation Instructions: V-552P

1/2" SK-200 Double Operated Valves
3-Position

ISSUED: May, 2001

Supersedes: November, 1998

ECN #9369 Rev. 6

WARNING

To avoid unpredictable system behavior that can cause personal injury and property damage:

- Disconnect air supply and depressurize all air lines connected to this product before installation, servicing, or conversion.
- Disconnect electrical supply before installation, servicing or conversion.
- Operate within the manufacturer's specified pressure, temperature, voltage and other conditions listed in these instructions.
- Medium must be moisture-free if ambient temperature is below freezing.
- Service according to procedures listed on these instructions.
- Installation, service and conversion of these products must be performed by knowledgeable personnel who understand how pneumatic products are to be applied.
- After installation, servicing, or conversion, air and electrical supplies should be connected and the product tested for proper function and leakage. If audible leakage is present, or the product does not operate properly, do not put into use.
- Warnings and specifications on the product should not be covered by paint, etc. If masking is not possible, contact your local representative for replacement label.

INSTALLATION / OPERATING INSTRUCTIONS

Valve should be installed with reasonable accessibility for service whenever possible -- repair service kits are available. Keep pipe or tubing lengths to a minimum with inside clean and free of dirt and chips. Pipe joint compound should be used sparingly and applied only to the male pipe -- never into the female port. Do not use PTFE tape to seal pipe joints -- pieces have a tendency to break off and lodge inside the unit, possibly causing malfunction. Mounting bolt torque 80-90 in-lb. for manifold and subbase mounting valves.

Air applied to the valve must be filtered to realize maximum component life.

Life Expectancy - Normal multi-million cycle life expectancy of these valves is based on the use of properly filtered and lubricated air at room temperature. However, these valves contain o-rings specially compounded with 12% molybdenum disulfide to assure long wear in applications where air line lubrication is undesirable.

Factory Pre-Lubrication - Valves are pre-lubricated at assembly with Sunaplex 781 or equivalent (Petroleum Base - Lithium Content) grease. Valves specified for vacuum service are lubricated with Dow Corning Valve Seal A.

In-Service Lubrication - F442 oil is recommended for in-service lubrication. This oil is specially formulated to provide peak performance and maximum service life from all air operated equipment. Otherwise, use an air line lubricant (compatible with Nitrile & Polyurethane seals) which will readily atomize and be of the medium aniline type. Aniline point range must be between 180° and 220° F. Viscosity at 100° F: 140 - 170 SUS.

CAUTION: Do not use synthetic, reconstituted, or oils with an alcohol content or detergent additive.

Override Operation - To operate override push and turn to a full stop (at least 90°).

3-Position Valves are available in the following three classes of neutral or centered position (7th & 8th digits of model number):

- "Class 21" - All ports blocked
- "Class 22" - Pressure to cylinder ports (Exhaust ports blocked)
- "Class 23" - Cylinder to exhaust ports (Inlet port blocked)

See the associated ANSI symbols on back.

APPLICATION LIMITS

These products are intended for use in general purpose compressed air systems only.

Pressure Range for Solenoid Operated Valves

Media	Solenoid Pilot Supply Source					
	Internal Pilot Supply			External Pilot Supply		
	PSIG	BAR	kPa	PSIG	BAR	kPa
Air	Valve Inlet			Valve Inlet		
	Minimum	35	2.41	241	Minimum	0 0 0
	Maximum	140*	9.65	965	Maximum	250* 17.24 1724
	Pilot Supply Port			Pilot Supply Port		
	PLUGGED			Minimum 35 2.41 241		
				Maximum 140* 9.65 965		
Vacuum	DO NOT USE			Valve Inlet		
				Within 1" Hg of Perfect		
				Pilot Supply Port		
				Minimum 35 2.41 241		
				Maximum 140* 9.65 965		

* Unless valve is equipped with 200 PSIG pilot valve (9th digit of model number is a "3", i.e. L5255810353 SK-200 Series only).

Pressure Range for Remote Pilot Operated Valves

Media	PSIG BAR kPa			PSIG BAR kPa		
	Air	Valve Inlet			Remote Pilot Signal	
Minimum		0 0 0	0	Minimum	35 2.41 241	
Maximum		250 17.24 1724		Maximum	200 13.79 1379	
Vacuum	Valve Inlet			Remote Pilot Signal		
	Within 1" Hg of Perfect			Minimum 35 2.41 241		
				Maximum 200 13.79 1379		

Operating Temperature Range:

Operator Type	Duty Cycle	Minimum Ambient Temperature	Maximum Ambient Temperature
Standard Service Solenoid	Intermittent	0°F (-18°C)	125°F (52°C)
	Continuous	0°F (-18°C)	100°F (38°C)
Special Service Solenoid	Intermittent	0°F (-18°C)	125°F (52°C)
	Continuous	0°F (-18°C)	125°F (52°C)
Remote Pilot	Not Applicable	0°F (-18°C)	200°F (93°C)

Voltage Range: +10% to -15% of rating

WIRING INSTRUCTIONS

Units with flying leads

Either wire may be "Hot".

CAUTION: DC solenoids with indicator lights and/or arc suppression coils are polarity sensitive. Use red wire as positive.

Units with plug-in subbases or manifolds

Use wires marked "1" and "2" for Solenoid "A". Use wires marked "3" and "4" for solenoid "B". For units with DC solenoids and indicator lights or arc suppression coils, wires marked "1" and "3" are positive.

CAUTION: DC solenoids with indicator lights or arc suppression coils are polarity sensitive. Observe polarities indicated above.

CAUTION: An interruption of 10 milliseconds or greater to the power supplied to the solenoid of a solenoid operated valve may cause the valve to shift. Provision must be made to prevent power interruption of this duration to avoid unintended, potentially hazardous, consequences.

Earth ground: All electrically operated valves must be provided a proper earth ground. Connect to green wire from valve.

NOTE: In addition to the above instructions, follow all requirements for local and national electrical codes.

Remote Pilot Operated Valves require the use of two normally open pilot signal valves to ensure that the spool returns to the center position upon removal of electrical power from both pilot signal valves. This is because the valve is designed to use pressure instead of springs to perform this function.

CAUTION: Failure to use two normally open pilot signal valves could result in the valve remaining in some position other than

ANSI SYMBOLS

Double Solenoid Operated

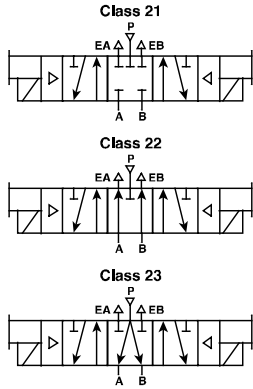

Double Remote Pilot Operated

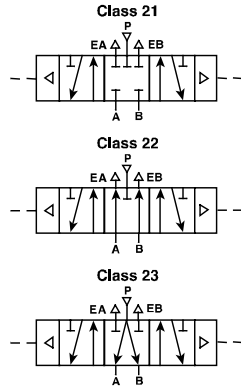

INSTALLATION

Manifold and Subbase Mounted Valves

See *Installation Instructions V-543P 3/8" & 1/2" Series Subbases and Manifolds* packed with subbases and manifolds.

Direct Pipe Ported Valves

PORT CONNECTIONS

- 1) Connect a single inlet air supply to port "P". (For dual pressure applications, connect inlet air supplies to ports "EA" and "EB".)
- 2) Connect mufflers (or plumb exhaust) from ports "EA" and "EB" for single air supply. (For dual pressure applications, connect to port "P".)
- 3) Connect cylinder ports "A" and "B" to ends of cylinder or other device to be supplied air.

CONVERSION PROCEDURE FOR EXTERNAL PILOT

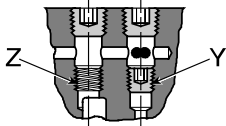

Base Mounted

For field conversion to external pilot supply, remove (2) 1/8" pipe plugs from top of valve body and move bottom plug from "Y" to "Z". Replace 1/8" pipe plugs and connect pilot pressure to the 1/4" pipe external pilot supply port "X" in subbase or manifold.

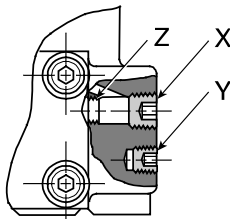

Direct Pipe Ported

For field conversion to external pilot supply, remove and discard 1/4" pipe plug in external pilot supply port "X". Move stored plug "Y" to location "Z" in bottom of pilot supply port "X". Then connect pilot pressure to port "X" in valve body.

EXTERNAL PILOT SUPPLY CONNECTION

Use an external pilot for dual inlet air supplies, for inlet pressures below minimum valve ratings, or any other application requiring pilot pressure different than main supply pressure.

- 1) Perform **Conversion Procedure for External Pilot**.
- 2) Connect pilot supply source to port "X".

SERVICE KITS / PARTS

Service Kit (Double Solenoid - Standard Service)	K352153
Service Kit (Double Solenoid - Special Service)	K352353
Service Kit (Double Remote Pilot Operated)	K352358
Pilot Valve / Remote Pilot Gasket	K183001
Body to Base Gasket	K183030
Indicator Light (24VDC - Line Mounting)	H19110
Indicator Light (24VDC - Base Mounting)	H19112
Indicator Light (120V / 60 HZ - Line Mounting)	H19102
Indicator Light (120V / 60 HZ - Base Mounting)	H19105

Direct Pipe Ported Valves

Voltage			Coil	
60 Hz	50 Hz	D. C.	19" Leads	72" Leads
12	--	--	K593007	K593178
24	--	6	K593003	K593179
--	24	--	K593015	K593181
--	36	--	K593016	K593183
--	--	12	K593010	K593182
--	--	24	K593014	K593184
--	--	(Standard)		
--	--	24	K593271	K593272
--	--	(Arc Suppressed)		
--	--	48	K593028	K593185
120	110	--	K593025	K593186
240	220	--	K593035	K593187
--	240	--	K593033	K593188
--	--	90	K593020	K593189
--	--	115	K593041	K593190
--	380	--	K593038	K593191

Base Mounting Valves

Voltage			Coil	
60 Hz	50 Hz	D. C.	No Light	With Light
12	--	--	K593052	--
24	--	6	K593048	--
--	24	--	K593061	--
--	36	--	K593062	--
--	--	12	K593055	--
--	--	24	K593060	K593274
--	--	(Standard)		
--	--	24	K593305	K593275
--	--	(Arc Suppressed)		
--	--	48	K593074	--
120	110	--	K593071	K593125
240	220	--	K593081	--
--	240	--	K593079	--

WARNING

FAILURE OR IMPROPER SELECTION OR IMPROPER USE OF THE PRODUCTS AND/OR SYSTEMS DESCRIBED HEREIN OR RELATED ITEMS CAN CAUSE DEATH, PERSONAL INJURY AND PROPERTY DAMAGE.

This document and other information from Parker Hannifin Corporation, its subsidiaries and authorized distributors provide product and/or system options for further investigation by users having technical expertise. It is important that you analyze all aspects of your application, including consequences of any failure, and review the information concerning the product or system in the current product catalog. Due to the variety of operating conditions and applications for these products or systems, the user, through its own analysis and testing, is solely responsible for making the final selection of the products and systems and assuring that all performance, safety and warning requirements of the application are met.

The products described herein, including without limitation, product features, specifications, designs, availability and pricing, are subject to change by Parker Hannifin Corporation and its subsidiaries at any time without notice.

EXTRA COPIES OF THESE INSTRUCTIONS ARE AVAILABLE FOR INCLUSION IN EQUIPMENT / MAINTENANCE INSTRUCTION MANUALS THAT UTILIZE THESE PRODUCTS. CONTACT YOUR LOCAL REPRESENTATIVE.



Pneumatic Division
Richland, Michigan 49083

Installation & Service Instructions
V553P

1/2" SK-200 / A5
Single Operated Valves

ISSUED: February, 2002
Supersedes: November, 2001
Doc.# V-553P, ECN# P28822, Rev. 3

⚠ WARNING

To avoid unpredictable system behavior that can cause personal injury and property damage:

- Disconnect electrical supply (when necessary) before installation, servicing, or conversion.
- Disconnect air supply and depressurize all air lines connected to this product before installation, servicing, or conversion.
- Operate within the manufacturer's specified pressure, temperature, and other conditions listed in these instructions.
- Medium must be moisture-free if ambient temperature is below freezing.
- Service according to procedures listed in these instructions.
- Installation, service, and conversion of these products must be performed by knowledgeable personnel who understand how pneumatic products are to be applied.
- After installation, servicing, or conversion, air and electrical supplies (when necessary) should be connected and the product tested for proper function and leakage. If audible leakage is present, or the product does not operate properly, do not put into use.
- Warnings and specifications on the product should not be covered by paint, etc. If masking is not possible, contact your local representative for replacement labels.

Introduction

Follow these instructions when installing, operating, or servicing the product.

Application Limits

These products are intended for use in general purpose compressed air systems only.

Pressure Range for Solenoid Operated Valves

Media	Solenoid Pilot Supply Source							
	Internal Pilot Supply			External Pilot Supply				
	PSIG	bar	kPa	PSIG	bar	kPa		
Air	Valve Inlet			Valve Inlet				
	Minimum	35	2.41	241	Minimum	0	0	0
	Maximum	140*	9.65	965	Maximum	250*	17.24	1724
Air	Pilot Supply Port PLUGGED			Pilot Supply Port				
	Minimum	35	2.41	241	Maximum	140*	9.65	965
Vacuum	DO NOT USE			Valve Inlet				
				Within 1" Hg of Perfect				
Vacuum	DO NOT USE			Pilot Supply Port				
				Minimum	35	2.41	241	Maximum

* Unless valve is equipped with 200 PSIG pilot valve (9th digit of model number is a "3", i.e. L5155810353 SK-200 Series only).

Pressure Range for Remote Pilot Operated Valves

Media	PSIG	bar	kPa	PSIG	bar	kPa		
Air	Valve Inlet			Remote Pilot Signal				
	Minimum	0	0	0	Minimum	35	2.41	241
	Maximum	250	17.24	1724	Maximum	200	13.79	1379
Vacuum	DO NOT USE							

Operating Temperature Range:

Operator Type	Duty Cycle	Minimum Ambient Temperature	Maximum Ambient Temperature
Standard Service Solenoid	Intermittent	0°F (-18°C)	125°F (52°C)
	Continuous	0°F (-18°C)	100°F (38°C)
Special Service Solenoid	Intermittent	0°F (-18°C)	125°F (52°C)
	Continuous	0°F (-18°C)	125°F (52°C)
Remote Pilot	Not Applicable	0°F (-18°C)	200°F (93°C)

Voltage Range: +10% to -15% of rating

Wiring Instructions

Units With Flying Leads

Either wire may be "Hot".

⚠ CAUTION: DC solenoids with indicator lights and / or arc suppression coils are polarity sensitive. Use red wire as positive.

Units With Plug-in Subbases or Manifolds

Use wires marked "2" and "3" for connection to the solenoid. Either may be "Hot".

⚠ CAUTION: DC solenoids with indicator lights and / or arc suppression coils are polarity sensitive. Use wire number 3 for single solenoid valves as positive.

Earth ground: All electrically operated valves must be provided a proper earth ground. Connect to green wire from valve.

NOTE: In addition to the above instructions, follow all requirements for local and national electrical codes.

Service Procedures

NOTE: All cleaning of parts to be done with mineral spirits or equivalent cleaning solution. Grease should be a mineral based lubricant (Magnalube G). All parts showing nicks, scratches or other signs of wear or damage should be replaced.

⚠ WARNING

FAILURE OR IMPROPER SELECTION OR IMPROPER USE OF THE PRODUCTS AND/OR SYSTEMS DESCRIBED HEREIN OR RELATED ITEMS CAN CAUSE DEATH, PERSONAL INJURY AND PROPERTY DAMAGE.

This document and other information from Parker Hannifin Corporation, its subsidiaries and authorized distributors provide product and/or system options for further investigation by users having technical expertise. It is important that you analyze all aspects of your application, including consequences of any failure and review the information concerning the product or systems in the current product catalog. Due to the variety of operating conditions and applications for these products or systems, the user, through its own analysis and testing, is solely responsible for making the final selection of the products and systems and assuring that all performance, safety and warning requirements of the application are met.

The products described herein, including without limitation, product features, specifications, designs, availability and pricing, are subject to change by Parker Hannifin Corporation and its subsidiaries at any time without notice.

EXTRA COPIES OF THESE INSTRUCTIONS ARE AVAILABLE FOR INCLUSION IN EQUIPMENT / MAINTENANCE MANUALS THAT UTILIZE THESE PRODUCTS. CONTACT YOUR LOCAL REPRESENTATIVE.

Valve Service

1. Orient valve with Solenoid "B" on the left hand side. (Letters "A" and "B" are cast into the sides of the body near each end.)
2. Loosen (4) socket head cap screws (A) on each end of valve until they disengage from body.
3. Remove end caps (B), bumpers (C) and seal (D). Discard seal.
4. Insert finger into right end of body and push spool assembly (E) out left end.
5. Remove and discard u-cup (F) from spool assembly. Clean spool assembly. Apply grease to new u-cup from kit and assemble to spool assembly (open end toward spool).
6. Remove long end spacer (G), o-rings (H), spacers (J) and short spacer ring (K). Discard o-rings. Clean spacers.
7. Apply lubricant (tube in kit) to o-rings (H).
8. Reassemble short spacer ring (K), an o-ring (H) and one spacer (J). Alternatively assemble an o-ring and a spacer until all o-rings and spacers are used. Press each set firmly into place.
9. Reassemble long end spacer (G).
10. On right end of valve, assemble bumper (C) and end cap (B). Tighten (4) socket head screws (A) to 150-190 in-lb.
11. Slide spool assembly (E) into left end of valve.
12. On left end of valve, assemble seal (D), bumper (C), end cap (B), and tighten (4) socket head screws (A) to 150-190 in-lb.

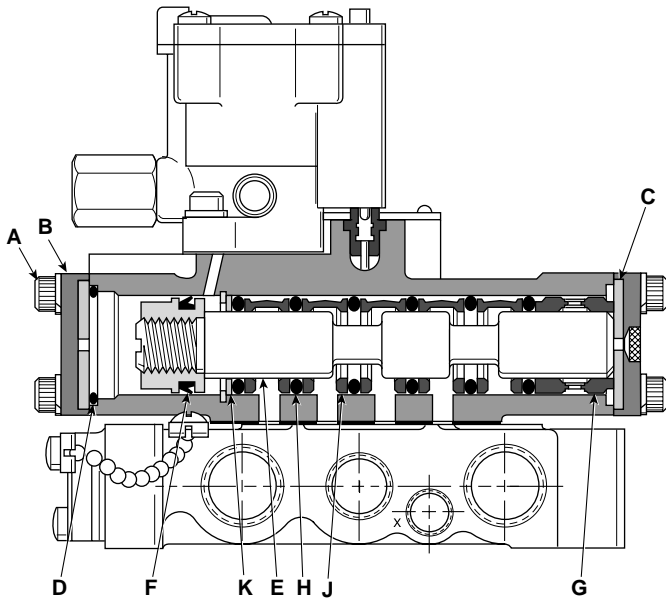

Pilot Valve Service

See *Service Instructions V-644P L-Pilot Valves and Operators* packed with **Pilot Valve Service Kit K352166** included in this kit.

Coil / Indicator Light Replacement

See *Service Instructions V-644P L-Pilot Valves and Operators* packed with replacement coils and lights.

Manual Override Replacement Or Conversion

The following override assemblies are interchangeable and can be replaced or field converted:

- Non-locking override K162001
- Locking override K152003
- Extended locking override K152006

Remove override and clean internal threads in housing. Apply pipe sealant sparingly to threads of override housing and assemble override to pilot valve housing.

NOTE: Overrides are held out by air pressure and may not extend until pressure is reapplied to the valve.

Conversion Procedure For External Pilot

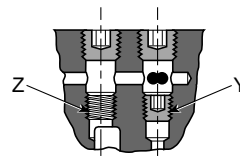

Base Mounted

For field conversion to external pilot supply, remove (2) 1/8" pipe plugs from top of valve body and move bottom plug from "Y" to "Z". Replace 1/8" pipe plugs and connect pilot pressure to the 1/4" pipe external pilot supply port "X" in subbase or manifold.

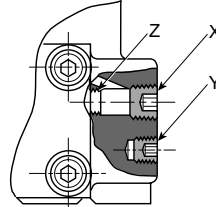

Direct Pipe Ported

For field conversion to external pilot supply, remove and discard 1/4" pipe plug in external pilot supply port "X". Move stored plug "Y" to location "Z" in bottom of pilot supply port "X". Then connect pilot pressure to port "X" in valve body.

Service Kits / Parts

Service Kit (Single Solenoid - Standard Service)	K352152
Service Kit (Single Solenoid - Special Service)	K352352
Service Kit (Single Remote - Pilot Operated)	K352361
Pilot Valve / Remote Pilot Gasket.	K183001
Body to Base Gasket.....	K183030
Indicator Light (24VDC - Line Mounting)	H19110
Indicator Light (24VDC - Base Mounting)	H19112
Indicator Light (120V / 60 HZ - Line Mounting)	H19102
Indicator Light (120V / 60 HZ - Base Mounting)	H19105

Direct Pipe Ported Valves

Voltage			Coil	
60 Hz	50 Hz	D. C.	19" Leads	72" Leads
12	—	—	K593007	K593178
24	—	6	K593003	K593179
—	24	—	K593015	K593181
—	36	—	K593016	K593183
—	—	12	K593010	K593182
—	—	24	K593014	K593184
—	—	(Standard)		
—	—	24	K593271	K593272
—	—	(Arc Suppressed)	K593028	K593185
—	—	48	K593025	K593186
120	110	—	K593035	K593187
240	220	—	K593033	K593188
—	240	—	K593020	K593189
—	—	90	K593041	K593190
—	—	115	K593038	K593191
—	380	—		

Base Mounting Valves

Voltage			Coil	
60 Hz	50 Hz	D. C.	No Light	With Light
12	—	—	K593052	—
24	—	6	K593048	—
—	24	—	K593061	—
—	36	—	K593062	—
—	—	12	K593055	—
—	—	24	K593060	K593274
—	—	(Standard)		
—	—	24	K593305	K593275
—	—	(Arc Suppressed)		
—	—	48	K593074	—
120	110	—	K593071	K593125
240	220	—	K593081	—
—	240	—	K593079	—



Pneumatic Division
Richland, Michigan 49083

Installation & Service Instructions
V554P
1/2" SK-200 / A5
Double Operated Valves, 2-Position
ISSUED: February, 2002
Supersedes: November, 2001
Doc.# V-554P, ECN# P28822, Rev. 3

! WARNING

To avoid unpredictable system behavior that can cause personal injury and property damage:

- Disconnect electrical supply (when necessary) before installation, servicing, or conversion.
- Disconnect air supply and depressurize all air lines connected to this product before installation, servicing, or conversion.
- Operate within the manufacturer's specified pressure, temperature, and other conditions listed in these instructions.
- Medium must be moisture-free if ambient temperature is below freezing.
- Service according to procedures listed in these instructions.
- Installation, service, and conversion of these products must be performed by knowledgeable personnel who understand how pneumatic products are to be applied.
- After installation, servicing, or conversion, air and electrical supplies (when necessary) should be connected and the product tested for proper function and leakage. If audible leakage is present, or the product does not operate properly, do not put into use.
- Warnings and specifications on the product should not be covered by paint, etc. If masking is not possible, contact your local representative for replacement labels.

Introduction

Follow these instructions when installing, operating, or servicing the product.

Application Limits

These products are intended for use in general purpose compressed air systems only.

Pressure Range for Solenoid Operated Valves

Media	Solenoid Pilot Supply Source							
	Internal Pilot Supply			External Pilot Supply				
	PSIG	bar	kPa	PSIG	bar	kPa		
Air	Valve Inlet			Valve Inlet				
	Minimum	35	2.41	241	Minimum	0	0	0
	Maximum	140*	9.65	965	Maximum	250*	17.24	1724
	Pilot Supply Port PLUGGED			Pilot Supply Port				
				Minimum	35	2.41	241	
				Maximum	140*	9.65	965	
Vacuum	DO NOT USE			Valve Inlet				
				Within 1" Hg of Perfect				
				Pilot Supply Port				
				Minimum	35	2.41	241	
				Maximum	140*	9.65	965	

* Unless valve is equipped with 200 PSIG pilot valve (9th digit of model number is a "3", i.e. L5155810353 SK-200 Series only).

Pressure Range for Remote Pilot Operated Valves

Media	PSIG bar kPa			PSIG bar kPa				
	PSIG	bar	kPa	PSIG	bar	kPa		
Air	Valve Inlet			Remote Pilot Signal				
	Minimum	0	0	0	Minimum	35	2.41	241
	Maximum	250	17.24	1724	Maximum	200	13.79	1379
Vacuum	Valve Inlet			Remote Pilot Signal				
	Within 1" Hg of Perfect			Minimum	35	2.41	241	
				Maximum	200	13.79	1379	

Operating Temperature Range:

Operator Type	Duty Cycle	Minimum Ambient Temperature	Maximum Ambient Temperature
Standard Service Solenoid	Intermittent	0°F (-18°C)	125°F (52°C)
	Continuous	0°F (-18°C)	100°F (38°C)
Special Service Solenoid	Intermittent	0°F (-18°C)	125°F (52°C)
	Continuous	0°F (-18°C)	125°F (52°C)
Remote Pilot	Not Applicable	0°F (-18°C)	200°F (93°C)

Voltage Range: +10% to -15% of rating

Wiring Instructions

Units With Flying Leads

Either wire may be "Hot".

! CAUTION: DC solenoids with indicator lights and / or arc suppression coils are polarity sensitive. Use red wire as positive.

Units With Plug-in Subbases or Manifolds

Use wires marked "1" and "2" for Solenoid "A". Use wires marked "3" and "4" for solenoid "B". For units with DC solenoids and indicator lights or arc suppression coils, wires marked "1" and "3" are positive.

! CAUTION: DC solenoids with indicator lights or arc suppression coils are polarity sensitive. Observe polarities indicated above.

Earth ground: All electrically operated valves must be provided a proper earth ground. Connect to green wire from valve.

NOTE: In addition to the above instructions, follow all requirements for local and national electrical codes.

Service Procedures

NOTE: All cleaning of parts to be done with mineral spirits or equivalent cleaning solution. Grease should be a mineral based lubricant (Magnalube G). All parts showing nicks, scratches or other signs of wear or damage should be replaced.

! WARNING

FAILURE OR IMPROPER SELECTION OR IMPROPER USE OF THE PRODUCTS AND/OR SYSTEMS DESCRIBED HEREIN OR RELATED ITEMS CAN CAUSE DEATH, PERSONAL INJURY AND PROPERTY DAMAGE.

This document and other information from Parker Hannifin Corporation, its subsidiaries and authorized distributors provide product and/or system options for further investigation by users having technical expertise. It is important that you analyze all aspects of your application, including consequences of any failure and review the information concerning the product or systems in the current product catalog. Due to the variety of operating conditions and applications for these products or systems, the user, through its own analysis and testing, is solely responsible for making the final selection of the products and systems and assuring that all performance, safety and warning requirements of the application are met.

The products described herein, including without limitation, product features, specifications, designs, availability and pricing, are subject to change by Parker Hannifin Corporation and its subsidiaries at any time without notice.

EXTRA COPIES OF THESE INSTRUCTIONS ARE AVAILABLE FOR INCLUSION IN EQUIPMENT / MAINTENANCE MANUALS THAT UTILIZE THESE PRODUCTS. CONTACT YOUR LOCAL REPRESENTATIVE.

Valve Service

1. Loosen (4) socket head cap screws (A) on each end of valve until they disengage from body.
2. Remove end caps (B), bumpers (C) and seals (D). Discard seals.
3. Insert finger into one end of body and push spool assembly (E) out other end. Clean spool.
4. Remove end spacers (F), o-rings (G), spacers (H) . Discard o-rings. Clean spacers.
5. Apply lubricant (tube in kit) to inner and outer o-rings (G).
6. Reassemble one end spacer (F), an o-ring (G) and one spacer (H). Alternatively assemble a set of o-ring and a spacer until all o-rings and spacers are used. Press each set firmly into place.
7. Reassemble other end spacer (F). Apply lubricant to seals (D) and place in ends of body.
8. On one end of valve, assemble bumper (C) and end cap (B). Tighten (4) socket head screws (A) to 150-190 in-lb.
9. Slide spool assembly (E) into open end of valve.
10. On other end of valve, assemble seal (D), bumper (C), end cap (B), and tighten (4) socket head screws (A) to 150-190 in-lb.

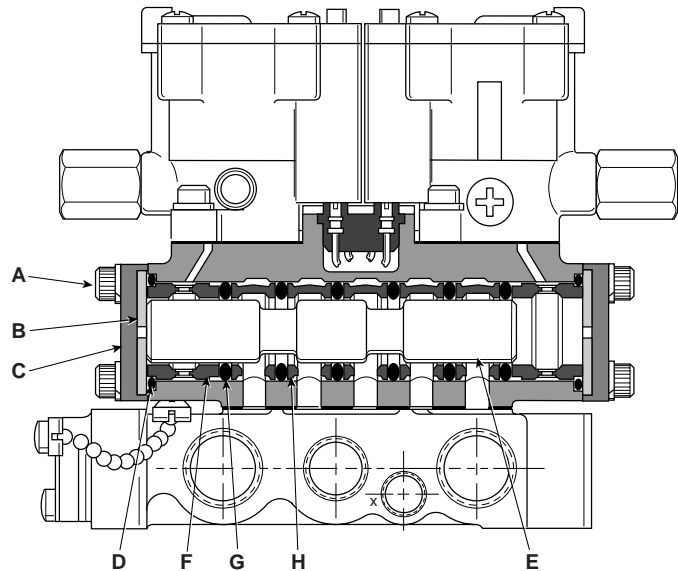

Pilot Valve Service

See *Service Instructions V-644P L-Pilot Valves and Operators* packed with **Pilot Valve Service Kit K352166** included in this kit.

Coil / Indicator Light Replacement

See *Service Instructions V-644P L-Pilot Valves and Operators* packed with replacement coils and lights.

Manual Override Replacement Or Conversion

The following override assemblies are interchangeable and can be replaced or field converted:

- Non-locking override K162001
- Locking override K152003
- Extended locking override K152006

Remove override and clean internal threads in housing. Apply pipe sealant sparingly to threads of override housing and assemble override to pilot valve housing.

NOTE: Overrides are held out by air pressure and may not extend until pressure is reapplied to the valve.

Conversion Procedure For External Pilot

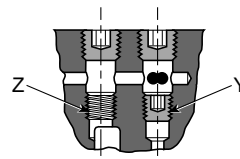

Base Mounted

For field conversion to external pilot supply, remove (2) 1/8" pipe plugs from top of valve body and move bottom plug from "Y" to "Z". Replace 1/8" pipe plugs and connect pilot pressure to the 1/4" pipe external pilot supply port "X" in subbase or manifold.

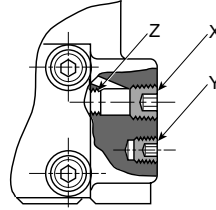

Direct Pipe Ported

For field conversion to external pilot supply, remove and discard 1/4" pipe plug in external pilot supply port "X". Move stored plug "Y" to location "Z" in bottom of pilot supply port "X". Then connect pilot pressure to port "X" in valve body.

Service Kits / Parts

- Service Kit (Single Solenoid - Standard Service) K352153
- Service Kit (Single Solenoid - Special Service) K352353
- Service Kit (Single Remote - Pilot Operated) K352358
- Pilot Valve / Remote Pilot Gasket. K183001
- Body to Base Gasket..... K183030
- Indicator Light (24VDC - Line Mounting) H19110
- Indicator Light (24VDC - Base Mounting) H19112
- Indicator Light (120V / 60 HZ - Line Mounting) H19102
- Indicator Light (120V / 60 HZ - Base Mounting) H19105

Direct Pipe Ported Valves

Voltage			Coil	
60 Hz	50 Hz	D. C.	19" Leads	72" Leads
12	—	—	K593007	K593178
24	—	6	K593003	K593179
—	24	—	K593015	K593181
—	36	—	K593016	K593183
—	—	12	K593010	K593182
—	—	24	K593014	K593184
—	—	24	K593271	K593272
—	—	(Arc Suppressed)	K593271	K593272
—	—	48	K593028	K593185
120	110	—	K593025	K593186
240	220	—	K593035	K593187
—	240	—	K593033	K593188
—	—	90	K593020	K593189
—	—	115	K593041	K593190
—	380	—	K593038	K593191

Base Mounting Valves

Voltage			Coil	
60 Hz	50 Hz	D. C.	No Light	With Light
12	—	—	K593052	—
24	—	6	K593048	—
—	24	—	K593061	—
—	36	—	K593062	—
—	—	12	K593055	—
—	—	24	K593060	K593274
—	—	24	K593305	K593275
—	—	(Arc Suppressed)	K593305	K593275
—	—	48	K593074	—
120	110	—	K593071	K593125
240	220	—	K593081	—
—	240	—	K593079	—



Pneumatic Division
Richland, Michigan 49083

Installation & Service Instructions
V555P
1/2" SK-200 / A5
Double Operated Valves, 3-Position
ISSUED: February, 2002
Supersedes: November, 2001
Doc.# V-555P, ECN# P28822, Rev. 3

! WARNING

To avoid unpredictable system behavior that can cause personal injury and property damage:

- Disconnect electrical supply (when necessary) before installation, servicing, or conversion.
- Disconnect air supply and depressurize all air lines connected to this product before installation, servicing, or conversion.
- Operate within the manufacturer's specified pressure, temperature, and other conditions listed in these instructions.
- Medium must be moisture-free if ambient temperature is below freezing.
- Service according to procedures listed in these instructions.
- Installation, service, and conversion of these products must be performed by knowledgeable personnel who understand how pneumatic products are to be applied.
- After installation, servicing, or conversion, air and electrical supplies (when necessary) should be connected and the product tested for proper function and leakage. If audible leakage is present, or the product does not operate properly, do not put into use.
- Warnings and specifications on the product should not be covered by paint, etc. If masking is not possible, contact your local representative for replacement labels.

Introduction

Follow these instructions when installing, operating, or servicing the product.

Application Limits

These products are intended for use in general purpose compressed air systems only.

Pressure Range for Solenoid Operated Valves

Media	Solenoid Pilot Supply Source							
	Internal Pilot Supply			External Pilot Supply				
	PSIG	bar	kPa	PSIG	bar	kPa		
Air	Valve Inlet			Valve Inlet				
	Minimum	35	2.41	241	Minimum	0	0	0
	Maximum	140*	9.65	965	Maximum	250*	17.24	1724
	Pilot Supply Port PLUGGED			Pilot Supply Port				
				Minimum	35	2.41	241	
				Maximum	140*	9.65	965	
Vacuum	DO NOT USE			Valve Inlet				
				Within 1" Hg of Perfect				
				Pilot Supply Port				
				Minimum	35	2.41	241	
				Maximum	140*	9.65	965	

* Unless valve is equipped with 200 PSIG pilot valve (9th digit of model number is a "3", i.e. L5255810353 SK-200 only).

Pressure Range for Remote Pilot Operated Valves

Media	PSIG	bar	kPa	PSIG	bar	kPa		
Air	Valve Inlet			Remote Pilot Signal				
	Minimum	0	0	0	Minimum	35	2.41	241
	Maximum	250	17.24	1724	Maximum	200	13.79	1379
Vacuum	Valve Inlet			Remote Pilot Signal				
	Within 1" Hg of Perfect			Minimum	35	2.41	241	
				Maximum	200	13.79	1379	

Operating Temperature Range:

Operator Type	Duty Cycle	Minimum Ambient Temperature	Maximum Ambient Temperature
Standard Service Solenoid	Intermittent	0°F (-18°C)	125°F (52°C)
	Continuous	0°F (-18°C)	100°F (38°C)
Special Service Solenoid	Intermittent	0°F (-18°C)	125°F (52°C)
	Continuous	0°F (-18°C)	125°F (52°C)
Remote Pilot	Not Applicable	0°F (-18°C)	200°F (93°C)

Voltage Range: +10% to -15% of rating

Wiring Instructions

Units With Flying Leads

Either wire may be "Hot".

! CAUTION: DC solenoids with indicator lights and / or arc suppression coils are polarity sensitive. Use red wire as positive.

Units With Plug-in Subbases or Manifolds

Use wires marked "1" and "2" for Solenoid "A". Use wires marked "3" and "4" for solenoid "B". For units with DC solenoids and indicator lights or arc suppression coils, wires marked "1" and "3" are positive.

! CAUTION: DC solenoids with indicator lights or arc suppression coils are polarity sensitive. Observe polarities indicated above.

Earth ground: All electrically operated valves must be provided a proper earth ground. Connect to green wire from valve.

NOTE: In addition to the above instructions, follow all requirements for local and national electrical codes.

Service Procedures

NOTE: All cleaning of parts to be done with mineral spirits or equivalent cleaning solution. Grease should be a mineral based lubricant (Magnalube G). All parts showing nicks, scratches or other signs of wear or damage should be replaced.

! WARNING

FAILURE OR IMPROPER SELECTION OR IMPROPER USE OF THE PRODUCTS AND/OR SYSTEMS DESCRIBED HEREIN OR RELATED ITEMS CAN CAUSE DEATH, PERSONAL INJURY AND PROPERTY DAMAGE.

This document and other information from Parker Hannifin Corporation, its subsidiaries and authorized distributors provide product and/or system options for further investigation by users having technical expertise. It is important that you analyze all aspects of your application, including consequences of any failure and review the information concerning the product or systems in the current product catalog. Due to the variety of operating conditions and applications for these products or systems, the user, through its own analysis and testing, is solely responsible for making the final selection of the products and systems and assuring that all performance, safety and warning requirements of the application are met.

The products described herein, including without limitation, product features, specifications, designs, availability and pricing, are subject to change by Parker Hannifin Corporation and its subsidiaries at any time without notice.

EXTRA COPIES OF THESE INSTRUCTIONS ARE AVAILABLE FOR INCLUSION IN EQUIPMENT / MAINTENANCE MANUALS THAT UTILIZE THESE PRODUCTS. CONTACT YOUR LOCAL REPRESENTATIVE.

Valve Service

- Loosen (4) socket head cap screws (A) on each end of valve until they detach end sections from body.
- End Section Disassembly** - Detach housing (B) from end section. Remove and discard seal (C). Push piston (D) out of housing. Remove and discard v-seals (E & F). Clean piston and housing.
- End Section Reassembly** - Apply lubricant (tube in kit) to v-seals (E & F) and piston bore in housing (B). Install v-seal (E) onto piston (D) with grooved end facing large diameter end of piston (D). Install v-seal (F) into housing with grooved end facing away from piston bore. Assemble piston (D) and seal (C) into housing. Place bumper (G) back into end cap (H) if it has become dislodged. Slide housing back over screws.
- Insert finger into one end of body and push spool (J) out other end. Clean spool.
- Remove seals (K), end spacers (L), o-rings (M), and spacers (N). Discard o-rings. Clean spacers and body bore.
- Apply lubricant (tube in kit) to o-rings (M).
- Reassemble one end spacer (L), an o-ring (M) and one spacer (N). Alternatively assemble an o-ring and a spacer until all o-rings and spacers are used. Press each set firmly into place.
- Reassemble left end spacer (L). Apply lubricant to seals (K) and place in ends of body.
- On one end of valve, assemble end section and tighten (4) socket head screws (A) to 150-190 in-lb.
- Slide spool (J) into open end of valve.
- On other end of valve, assemble end section and tighten (4) socket head screws (A) to 150-190 in-lb.

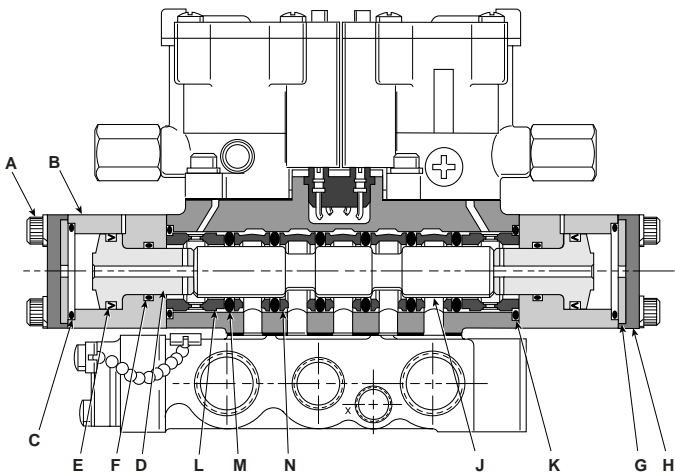

Pilot Valve Service

See *Service Instructions V-644P L-Pilot Valves and Operators* packed with **Pilot Valve Service Kit K352166** included in this kit.

Coil / Indicator Light Replacement

See *Service Instructions V-644P L-Pilot Valves and Operators* packed with replacement coils and lights.

Manual Override Replacement Or Conversion

The following override assemblies are interchangeable and can be replaced or field converted:

- Non-locking override K162001
- Locking override K152003
- Extended locking override K152006

Remove override and clean internal threads in housing. Apply pipe sealant sparingly to threads of override housing and assemble override to pilot valve housing.

NOTE: Overrides are held out by air pressure and may not extend until pressure is reapplied to the valve.

Conversion Procedure For External Pilot

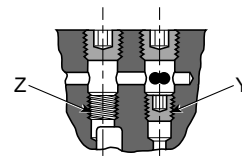

Base Mounted

For field conversion to external pilot supply, remove (2) 1/8" pipe plugs from top of valve body and move bottom plug from "Y" to "Z". Replace 1/8" pipe plugs and connect pilot pressure to the 1/4" pipe external pilot supply port "X" in subbase or manifold.

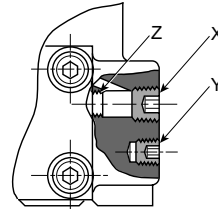

Direct Pipe Ported

For field conversion to external pilot supply, remove and discard 1/4" pipe plug in external pilot supply port "X". Move stored plug "Y" to location "Z" in bottom of pilot supply port "X". Then connect pilot pressure to port "X" in valve body.

Service Kits / Parts

Service Kit (Single Solenoid - Standard Service)	K352153
Service Kit (Single Solenoid - Special Service)	K352353
Service Kit (Single Remote - Pilot Operated)	K352358
Pilot Valve / Remote Pilot Gasket.	K183001
Body to Base Gasket.....	K183030
Indicator Light (24VDC - Line Mounting)	H19110
Indicator Light (24VDC - Base Mounting)	H19112
Indicator Light (120V / 60 HZ - Line Mounting)	H19102
Indicator Light (120V / 60 HZ - Base Mounting)	H19105

Direct Pipe Ported Valves

Voltage			Coil	
60 Hz	50 Hz	D. C.	19" Leads	72" Leads
12	—	—	K593007	K593178
24	—	6	K593003	K593179
—	24	—	K593015	K593181
—	36	—	K593016	K593183
—	—	12	K593010	K593182
—	—	24	K593014	K593184
—	—	(Standard)		
—	—	24	K593271	K593272
—	—	(Arc Suppressed)		
—	—	48	K593028	K593185
120	110	—	K593025	K593186
240	220	—	K593035	K593187
—	240	—	K593033	K593188
—	—	90	K593020	K593189
—	—	115	K593041	K593190
—	380	—	K593038	K593191

Base Mounting Valves

Voltage			Coil	
60 Hz	50 Hz	D. C.	No Light	With Light
12	—	—	K593052	—
24	—	6	K593048	—
—	24	—	K593061	—
—	36	—	K593062	—
—	—	12	K593055	—
—	—	24	K593060	K593274
—	—	(Standard)		
—	—	24	K593305	K593275
—	—	(Arc Suppressed)		
—	—	48	K593074	—
120	110	—	K593071	K593125
240	220	—	K593081	—
—	240	—	K593079	—



Pneumatic Division North America
 Richland, MI 49083

Installation Instructions: V-556P

1/2" SK-200 Single Solenoid Poppet Valves

ISSUED: May, 2001

Supersedes: November, 1998

ECN #9369 Rev. 7

WARNING

To avoid unpredictable system behavior that can cause personal injury and property damage:

- Disconnect air supply and depressurize all air lines connected to this product before installation, servicing, or conversion.
- Disconnect electrical supply before installation, servicing or conversion.
- Operate within the manufacturer's specified pressure, temperature, voltage and other conditions listed in these instructions.
- Medium must be moisture-free if ambient temperature is below freezing.
- Service according to procedures listed on these instructions.
- Installation, service and conversion of these products must be performed by knowledgeable personnel who understand how pneumatic products are to be applied.
- After installation, servicing, or conversion, air and electrical supplies should be connected and the product tested for proper function and leakage. If audible leakage is present, or the product does not operate properly, do not put into use.
- Warnings and specifications on the product should not be covered by paint, etc. If masking is not possible, contact your local representative for replacement labels.

INSTALLATION / OPERATING INSTRUCTIONS

Valve should be installed with reasonable accessibility for service whenever possible -- repair service kits are available. Keep pipe or tubing lengths to a minimum with inside clean and free of dirt and chips. Pipe joint compound should be used sparingly and applied only to the male pipe -- never into the female port. Do not use PTFE tape to seal pipe joints -- pieces have a tendency to break off and lodge inside the unit, possibly causing malfunction. Mounting bolt torque 80-90 in-lb. for manifold and subbase mounting valves.

Air applied to the valve must be filtered to realize maximum component life.

Life Expectancy - Normal multi-million cycle life expectancy of these valves is based on the use of properly filtered and lubricated air at room temperature. However, these valves contain o-rings specially compounded with 12% molybdenum disulfide to assure long wear in applications where air line lubrication is undesirable.

Factory Pre-Lubrication - Valves are pre-lubricated at assembly with Sunaplex 781 or equivalent (Petroleum Base - Lithium Content) grease. Valves specified for vacuum service are lubricated with Dow Corning Valve Seal A.

In-Service Lubrication - F442 oil is recommended for in-service lubrication. This oil is specially formulated to provide peak performance and maximum service life from all air operated equipment. Otherwise, use an air line lubricant (compatible with Nitrile seals) which will readily atomize and be of the medium aniline type. Aniline point range must be between 180° and 220° F. Viscosity at 100° F: 140 - 170 SUS.

CAUTION: Do not use synthetic, reconstituted, or oils with an alcohol content or detergent additive.

Override Operation - To operate override push and turn to a full stop (at least 90°).

ANSI SYMBOL

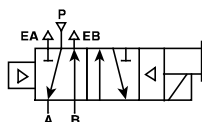

APPLICATION

LIMITS

These products are intended for use in general purpose compressed air systems only.

Media	Solenoid Pilot Supply Source					
	Internal Pilot Supply			External Pilot Supply		
	PSIG	BAR	kPa	PSIG	BAR	kPa
Air	Valve Inlet			Valve Inlet		
	Minimum	35	2.41	241	Minimum	0 0 0
	Maximum	140*	9.65	965	Maximum	250* 17.24 1724
	Pilot Supply Port			Pilot Supply Port		
	PLUGGED			Minimum 35 2.41 241		
				Maximum 140* 9.65 965		
Vacuum	DO NOT USE			Valve Inlet		
				Within 1" Hg of Perfect		
				Pilot Supply Port		
				Minimum 35 2.41 241		
				Maximum 140* 9.65 965		

* Unless valve is equipped with 200 PSIG pilot valve (9th digit of model number is a "3", i.e. L3854810353).

Operating Temperature Range:

Operator Type	Duty Cycle	Minimum Ambient Temperature	Maximum Ambient Temperature
Standard Service Solenoid	Intermittent	0°F (-18°C)	125° F (52° C)
	Continuous	0°F (-18°C)	100° F (38° C)
Special Service Solenoid	Intermittent	0°F (-18°C)	125° F (52° C)
	Continuous	0°F (-18°C)	125° F (52° C)

Voltage Range:

+10% to -15% of rating

WIRING INSTRUCTIONS

Use wires marked "2" and "3" for connection to the solenoid. Either may be "Hot".

CAUTION: DC solenoids with indicator lights and/or arc suppression coils are polarity sensitive. Use wire number 3 for single solenoid valves as positive.

CAUTION: An interruption of 10 milliseconds or greater to the power supplied to the solenoid of a solenoid operated valve may cause the valve to shift. Provision must be made to prevent power interruption of this duration to avoid unintended, potentially hazardous, consequences.

Earth ground: All electrically operated valves must be provided a proper earth ground. Connect to green wire from valve.

NOTE: In addition to the above instructions, follow all requirements for local and national electrical codes.

INSTALLATION

VALVE MOUNTING PROCEDURES

- 1) Clean top surface of subbase or manifold and bottom surface of valve body of any dirt or dust.
- 2) Position gasket on top of subbase or manifold, lining up all four mounting holes.
- 3) Place valve on top of gasket, lining up all four mounting holes. Electrically operated valves also require pressing down on valve to seat electrical plug.
- 4) Insert (4) valve mounting screws and torque to 80 - 90 in-lb. in progressive steps with a criss-cross pattern.

SUBBASE PORT CONNECTIONS

(See reverse for Manifold Port Connections)

- 1) Connect a single inlet air supply to port "P". (For dual pressure applications, connect inlet air supplies to ports "EA" and "EB".)
- 2) Connect mufflers (or plumb exhaust) from ports "EA" and "EB" for single air supply. (For dual pressure applications, connect to port "P".)
- 3) Connect cylinders ports "A" and "B" to ends of cylinder or other device to be supplied air.

INSTALLATION

MANIFOLD APPLICATION

Valves may be gang manifolded up to any number of stations, providing that sufficient pressure is realized in the circuits down-stream of the valve outlets; and sufficient pressure is available for shifting the valves. Longer manifold gangs may require intermediate supports. Means to increase pressure levels include supply connections at both ends of the manifold gang, external pilot supplies and sequencing the valve operation to maximize time between different valve shifts.

WARNING: Air exhausting from one valve into the exhaust gallery of the manifold may pressurize other valve circuits open to the same gallery. Design the circuit such that there is no hazard or damage consequence from this action.

MANIFOLD ASSEMBLY PROCEDURES

Manifolds may be assembled to one another either before or after assembling valves to manifolds. If inlet, exhaust or external pilot galleries are to be isolated from neighboring manifolds, be sure to follow **Manifold Isolation Procedures** before proceeding with this section.

- 1) If wiring is to be done in manifold junction boxes, rather than in an external junction box, loosen electrical cover mounting screws on end of manifolds, remove covers and pull wires out through cover openings.
- 2) Clean counterbores inside of manifold and mating surface of neighboring manifold.
- 3) Apply light coating of grease (in kit) to o-rings and place in counterbores.
- 4) Place manifold next to neighboring manifold. If wiring is to be done in an external junction box, pull wires through conduit gallery of neighboring manifold.
- 5) Insert hex head screws through clearance holes in one manifold and screw into neighboring manifold. Torque screws to 160-180 in-lb.
- 6) Connect a grounding wire to the green ground screw of at least one manifold and feed this wire through conduit gallery to either end of manifold.
- 7) Replace electrical covers and tighten cover screws.

MANIFOLD PORT CONNECTIONS

(See front for Subbase Port Connections)

- 1) Connect inlet air supply to manifold inlet gallery by one of the following methods:
All valves to be supplied with a common pressure: Connect air supply to port "P" on either end of manifold package and plug other end port "P" (or connect air supply to both ends for applications requiring a larger volume of air).
Two groups of valves each requiring a different pressure: Isolate valves into two groups using **Manifold Isolation Procedures**. Connect appropriate air supply to each end of manifold bank at port "P".
- 2) Connect mufflers (or plumb exhaust) at "E" ports.
- 3) Connect cylinder ports "A" and "B" to ends of cylinder or other device to be supplied air. Connections are commonly made to ports on end of manifold opposite wiring cavity. If bottom ports are more accessible to your application, plug end cylinder ports and remove plugs from bottom ports.

MANIFOLD EXTERNAL PILOT CONNECTIONS

(See front for Subbase External Pilot Supply Connections)

Use an external pilot for dual inlet air supplies, for inlet pressures below minimum valve ratings, or any other application requiring pilot pressure different than main supply pressure.

- 1) Perform pilot supply conversion outlined on Installation Instructions packed with valve.
- 2) Isolate external pilot supply gallery (designate by "X") to those valves requiring external pilot supply.
- 3) Connect pilot supply to the "X" port gallery, or to those stations requiring external pilot supply, at their alternate "X" port connection. Plug all open "X" ports.

MANIFOLD ISOLATION PROCEDURES

Inlet and exhaust galleries may be isolated from those in neighboring manifolds through the use of flush pipe plugs.

- 1) Determine gallery and manifold position to be isolated.
- 2) Apply pipe sealant to threads of pipe plug.
- 3) Screw pipe plug into threaded end of gallery and tighten.

CONVERSION PROCEDURE FOR EXTERNAL PILOT

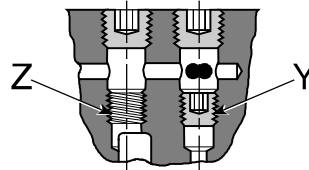

For field conversion to external pilot supply, remove (2) 1/8" pipe plugs from top of valve body and move bottom plug from "Y" to "Z". Replace 1/8" pipe plugs and connect pilot pressure to the 1/4" pipe external pilot supply port "X" in subbase or manifold.

SERVICE KITS / PARTS

- Service Kit (Single Solenoid - Standard Service) K352088
- Service Kit (Single Solenoid - Special Service) K352089
- Pilot Valve / Remote Pilot Gasket K183001
- Body to Base Gasket K183030
- Indicator Light (24VDC - Base Mounting) H19112
- Indicator Light (120V / 60 HZ - Base Mounting) H19105

Voltage			Coil	
60 Hz	50 Hz	D. C.	No Light	With Light
12	--	--	K593052	--
24	--	6	K593048	--
--	24	--	K593061	--
--	36	--	K593062	--
--	--	12	K593055	--
--	--	24 (Standard)	K593060	K593274
--	--	24 (Arc Suppressed)	K593305	K593275
--	--	48	K593074	--
120	110	--	K593071	K593125
240	220	--	K593081	--
--	240	--	K593079	--

WARNING

FAILURE OR IMPROPER SELECTION OR IMPROPER USE OF THE PRODUCTS AND/OR SYSTEMS DESCRIBED HEREIN OR RELATED ITEMS CAN CAUSE DEATH, PERSONAL INJURY AND PROPERTY DAMAGE.

This document and other information from The Parker Hannifin Corporation, its subsidiaries and authorized distributors provide product and/or system options for further investigation by users having technical expertise. It is important that you analyze all aspects of your application, including consequences of any failure, and review the information concerning the product or system in the current product catalog. Due to the variety of operating conditions and applications for these products or systems, the user, through its own analysis and testing, is solely responsible for making the final selection of the products and systems and assuring that all performance, safety and warning requirements of the application are met.

The products described herein, including without limitation, product features, specifications, designs, availability and pricing, are subject to change by Parker Hannifin Corporation and its subsidiaries at any time without notice.



Pneumatic Division North America
Richland, MI 49083

Service Instructions: V-557P

1/2" SK-200 Single Solenoid Poppet Valves

ISSUED: November, 1998

Supersedes: K583-392, March, 1996

ECN #8910

WARNING

To avoid unpredictable system behavior that can cause personal injury and property damage:

- Disconnect air supply and depressurize all air lines connected to this product before installation, servicing, or conversion.
- Disconnect electrical supply before installation, servicing or conversion.
- Operate within the manufacturer's specified pressure, temperature, voltage and other conditions listed in these instructions.
- Medium must be moisture-free if ambient temperature is below freezing.
- Service according to procedures listed on these instructions.
- Installation, service and conversion of these products must be performed by knowledgeable personnel who understand how pneumatic products are to be applied.
- After installation, servicing, or conversion, air and electrical supplies should be connected and the product tested for proper function and leakage. If audible leakage is present, or the product does not operate properly, do not put into use.
- Warnings and specifications on the product should not be covered by paint, etc. If masking is not possible, contact your local representative for replacement labels.

APPLICATION LIMITS

These products are intended for use in general purpose compressed air systems only.

Media	Solenoid Pilot Supply Source			External Pilot Supply				
	PSIG	BAR	kPa	PSIG	BAR	kPa		
Air	Valve Inlet			Valve Inlet				
	Minimum	35	2.41	241	Minimum	0	0	0
	Maximum	140*	9.65	965	Maximum	250*	17.24	1724
	Pilot Supply Port PLUGGED			Pilot Supply Port				
	Minimum	35	2.41	241	Maximum	140*	9.65	965
Vacuum	DO NOT USE			Valve Inlet				
				Within 1" Hg of Perfect				
				Pilot Supply Port				
	Minimum	35	2.41	241	Maximum	140*	9.65	965

* Unless valve is equipped with 200 PSIG pilot valve (9th digit of model number is a "3", i.e. L3854810353).

Operating Temperature Range:

Operator Type	Duty Cycle	Minimum Ambient Temperature	Maximum Ambient Temperature
Standard Service Solenoid	Intermittent	0°F (-18°C)	125°F (52°C)
	Continuous	0°F (-18°C)	100°F (38°C)
Special Service Solenoid	Intermittent	0°F (-18°C)	125°F (52°C)
	Continuous	0°F (-18°C)	125°F (52°C)

Voltage Range: +10% to -15% of rating

WIRING INSTRUCTIONS

Use wires marked "2" and "3" for connection to the solenoid. Either may be "Hot".



CAUTION: DC solenoids with indicator lights and/or arc suppression coils are polarity sensitive. Use wire number 3 for single solenoid valves as positive.

Earth ground: All electrically operated valves must be provided a proper earth ground. Connect to green wire from valve.

NOTE: In addition to the above instructions, follow all requirements for local and national electrical codes.

SERVICE PROCEDURES

NOTE: All cleaning of parts to be done with mineral spirits or equivalent cleaning solution. Grease should be a mineral based lubricant (Sunaplex 781). All parts showing nicks, scratches or other signs of wear or damage should be replaced.

Valve Service

DISASSEMBLY

- 1) Orient valve with Solenoid 'B' on the right hand side. (Letters 'A' and 'B' are cast into the sides of the body near each end.)
- 2) Remove end cap assembly (A) from left end of valve and end cap (B) from right end of valve.
- 3) Remove socket head cap screws (C & D) and washers (E) from each end of valve.
- 4) Remove piston assembly (F) from right end of valve.
- 5) Pull piston (G), stem (H), end spacer (J), poppet assembly (K), spring (L), spacer (M), and poppet assembly (K) from left end of valve.
- 6) Push remaining end spacer (J) and piston (G) out left end of valve.
- 7) Remove retaining ring (N) from piston assembly (F) with retaining ring pliers. Separate inner piston (P) from outer piston (R).
- 8) Remove and discard all o-rings from parts removed. Clean parts and examine for signs of wear.

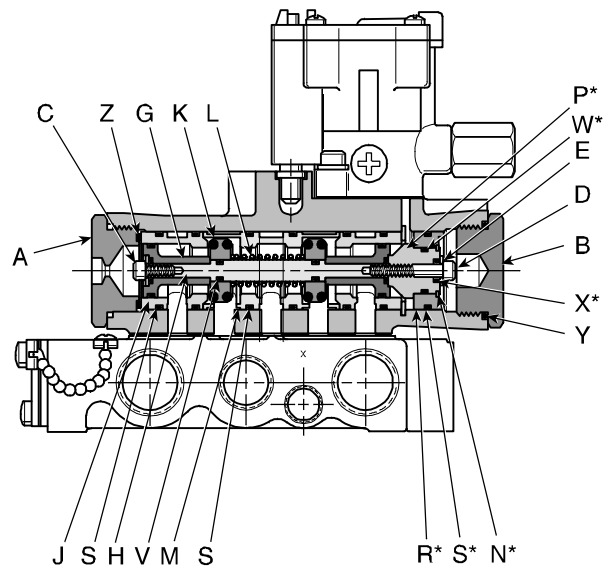

* Contained in (F).

ITEM	QUAN	DESCRIPTION	ITEM	QUAN	DESCRIPTION
A	1	End Cap Assembly	N	1	Retaining Ring
B	1	End Cap	P	1	Inner Piston
C	1	#10-32 X 3/8 LG SHCS	R	1	Outer Piston
D	1	#10-32 X 1-1/4 LG SHCS	S	7	1.174 ID X .103 W O'ring
E	2	#10 Washer	T	2	.737 ID X .103 W O'ring
F	1	Piston Assembly	U	2	.301 ID X .070 W O'ring
G	2	Piston	V	2	.239 ID X .070 W O'ring
H	1	Stem	W	1	.549 ID X .103 W O'ring
J	2	End Spacer	X	1	.176 ID X .070 W O'ring
K	2	Poppet Assembly	Y	1	1.414 ID X .103 W O'ring
L	1	Spring	Z	1	1.049 ID X .099 W Seal
M	1	Spacer			

SERVICE PROCEDURES (CONTINUED)

REASSEMBLY

- 1) Apply lubricant to all o-rings from kit, the main valve bore and stem (H).
- 2) Assemble o-rings (S) to spacer (M), end spacers (J) and outer piston (R). Assemble o-rings (T & U) to pistons (G). Assemble o-rings (V) to stem (H). Assemble o-rings (W & X) to inner piston (P).
- 3) Push inner piston (P) into outer piston (R). Reinstall retaining ring (N).
- 4) Slide one piston (G) onto stem (H).
- 5) Take the sub assemblies created in steps 3) and 4) and assemble using cap screw (D) and washer (E).
- 6) Slide one end spacer (J) into left end of valve until it stops on the retaining ring.
- 7) Slide the sub assembly created in step 5) into the right end of the valve.
- 8) From the left end of the valve - Slide one poppet assembly (K) and spring (L) onto stem (H). Next push spacer (M) into main valve bore. Slide other poppet assembly (K) onto stem (H). Push end spacer (J) into main valve bore. Slide piston (G) onto stem (H) and secure with cap screw (C) and washer (E).
- 9) Assemble o-ring (Y) to end cap (B). Screw end cap (B) into right end of valve and tighten to 30-40 ft.-lb.
- 10) Assemble seal (Z) to end cap (A). Screw end cap (A) into left end of valve and tighten to 30-40 ft.-lb.

Pilot Valve Service

See **Service Instructions V-644P L-Pilot Valves and Operators** packed with **Pilot Valve Service Kit K352166** included in this kit.

Coil / Indicator Light Replacement

See **Service Instructions V-644P L-Pilot Valves and Operators** packed with replacement coils and lights.

MANUAL OVERRIDE REPLACEMENT OR CONVERSION

The following override assemblies are interchangeable and can be replaced or field converted:

Non-locking override	K162001
Locking override	K152003
Extended locking override	K152006

Remove override and clean internal threads in housing. Apply pipe sealant sparingly to threads of override housing and assemble override to pilot valve housing.

NOTE: Overrides are held out by air pressure and may not extend until pressure is reapplied to the valve.

CONVERSION PROCEDURE FOR EXTERNAL PILOT

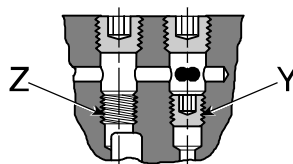

For field conversion to external pilot supply, remove (2) 1/8" pipe plugs from top of valve body and move bottom plug from "Y" to "Z". Replace 1/8" pipe plugs and connect pilot pressure to the 1/4" pipe external pilot supply port "X" in subbase or manifold.

SERVICE KITS / PARTS

Service Kit (Single Solenoid - Standard Service)	K352088
Service Kit (Single Solenoid - Special Service)	K352089
Poppet Assembly (2 required)	K242002
Pilot Valve / Remote Pilot Gasket	K183001
Body to Base Gasket	K183030
Indicator Light (24VDC - Base Mounting)	H19112
Indicator Light (120V / 60 HZ - Base Mounting)	H19105

Replacement Coils

Voltage			Coil	
60 Hz	50 Hz	D. C.	No Light	With Light
12	--	--	K593052	--
24	--	6	K593048	--
--	24	--	K593061	--
--	36	--	K593062	--
--	--	12	K593055	--
--	--	24 (Standard)	K593060	K593274
--	--	24 (Arc Suppressed)	K593305	K593275
--	--	48	K593074	--
120	110	--	K593071	K593125
240	220	--	K593081	--
--	240	--	K593079	--

⚠ WARNING

FAILURE OR IMPROPER SELECTION OR IMPROPER USE OF THE PRODUCTS AND/OR SYSTEMS DESCRIBED HEREIN OR RELATED ITEMS CAN CAUSE DEATH, PERSONAL INJURY AND PROPERTY DAMAGE.

This document and other information from Parker Hannifin Corporation, its subsidiaries and authorized distributors provide product and/or system options for further investigation by users having technical expertise. It is important that you analyze all aspects of your application, including consequences of any failure, and review the information concerning the product or system in the current product catalog. Due to the variety of operating conditions and applications for these products or systems, the user, through its own analysis and testing, is solely responsible for making the final selection of the products and systems and assuring that all performance, safety and warning requirements of the application are met.

The products described herein, including without limitation, product features, specifications, designs, availability and pricing, are subject to change by Parker Hannifin Corporation and its subsidiaries at any time without notice.

EXTRA COPIES OF THESE INSTRUCTIONS ARE AVAILABLE FOR INCLUSION IN EQUIPMENT / MAINTENANCE INSTRUCTION MANUALS THAT UTILIZE THESE PRODUCTS. CONTACT YOUR LOCAL REPRESENTATIVE.



Pneumatic Division North America
 Richland, Michigan 49083

Installation & Service Instructions:
 V-644P

L-Pilot and Operators

ISSUED: September, 1999
Supersedes: March, 1999

ECN# 9115

! WARNING

To avoid unpredictable system behavior that can cause personal injury and property damage:

- Disconnect electrical supply (when necessary) before installation, servicing, or conversion.
- Disconnect air supply and depressurize all air lines connected to this product before installation, servicing, or conversion.
- Operate within the manufacturer's specified pressure, temperature, and other conditions listed in these instructions.
- Medium must be moisture-free if ambient temperature is below freezing.
- Service according to procedures listed in these instructions.
- Installation, service, and conversion of these products must be performed by knowledgeable personnel who understand how pneumatic products are to be applied.
- After installation, servicing, or conversion, air and electrical supplies (when necessary) should be connected and the product tested for proper function and leakage. If audible leakage is present, or the product does not operate properly, do not put into use.
- Warnings and specifications on the product should not be covered by paint, etc. If masking is not possible, contact your local representative for replacement labels.

Application Limits

These products are intended for use in general purpose compressed air systems only.

0 PSIG Minimum/Maximum pressures vary with model. Take the 5th through 7th digits in the model number and then look up maximum rating in the following table.

Kxxx-xxxxx < Model Number
 "C"- (Orifice / Function Code)

C	psig	bar	kPa	C	psig	bar	kPa
001	250	17.24	1724	029	150	10.34	1034
003	200	13.79	1379	033	140	9.65	965
005	150	10.34	1034	035	140	9.65	965
007	200	13.79	1379	036	150	10.34	1034
009	200	13.79	1379	037	125	8.62	862
013	200	13.79	1379	039	90	6.21	621
014	200	13.79	1379	041	60	4.14	414
015	175	12.07	1207	043	90	6.21	621
017	140	9.65	965	045	90	6.21	621
019	90	6.21	621	054	90	6.21	621
021	90	6.21	621	056	90	6.21	621
023	130	8.96	896	080	150	10.34	1034
025	140	9.65	965				

Operating Temperature Range

Minimum*: -17°C (0°F)

Maximum (Standard Service): 37°C (100°F)

Maximum (Special Service): 52°C (125°F)

* In below-freezing ambient temperatures, it is important that a suitable lubricant be reasonably moisture-free .

Voltage Range: +10% to -15% of rating.

Wiring Instructions

(Units with flying leads)

Connect the two wires to suitable supply voltage. Either may be "Hot". (Plug-in valves are merely plugged into the mating power valve or manifold base.)

! CAUTION: An interruption of 10 milliseconds or greater to the power supplied to the solenoid of a solenoid operated valve may cause the valve to shift. Provision must be made to prevent power interruption of this duration to avoid unintended, potentially hazardous, consequences.

NOTE: In addition to above instructions, follow all requirements for local and national electrical codes.

Pilot Valve Replacement

1. Loosen and remove (2) socket head capscrews and lockwashers from mounting feet.
2. Remove pilot valve and gasket.
3. Place new gasket and pilot valve on top of power valve or base, aligning edges of gasket with footprint of pilot valve.
4. Screw capscrews (with lockwashers) into power valve or base. Tighten capscrews to 4.5 to 5.6 Nm (40 to 50 in. lbs.) torque by alternatively tightening screws in progressive steps.

Service Procedures

General Service (Conduit, JIC and Plug-In Style)

1. Loosen cover screws and remove cover and top plate. Remove and discard seals from top plate and underside of cover. Replace with new seals from kit.
2. Remove split sleeve and then pull up on coil while pushing lead wires toward center of housing.
3. Remove sleeve assembly, plunger and spring. Discard plunger (retain spring). Remove and replace tetraseal in bottom of housing with new one from kit.

! WARNING

FAILURE OR IMPROPER SELECTION OR IMPROPER USE OF THE PRODUCTS AND/OR SYSTEMS DESCRIBED HEREIN OR RELATED ITEMS CAN CAUSE DEATH, PERSONAL INJURY AND PROPERTY DAMAGE.

This document and other information from Parker Hannifin Corporation, its subsidiaries and authorized distributors provide product and/or system options for further investigation by users having technical expertise. It is important that you analyze all aspects of your application, including consequences of any failure and review the information concerning the product or systems in the current product catalog. Due to the variety of operating conditions and applications for these products or systems, the user, through its own analysis and testing, is solely responsible for making the final selection of the products and systems and assuring that all performance, safety and warning requirements of the application are met.

The products described herein, including without limitation, product features, specifications, designs, availability and pricing, are subject to change by Parker Hannifin Corporation and its subsidiaries at any time without notice.

EXTRA COPIES OF THESE INSTRUCTIONS ARE AVAILABLE FOR INCLUSION IN EQUIPMENT / MAINTENANCE MANUALS THAT UTILIZE THESE PRODUCTS. CONTACT YOUR LOCAL REPRESENTATIVE.

L-Pilot Valves and Operators Indicator Light Replacement

V-644P

Indicator Lights

Volts/Hertz	Plug-In Style	JIC Style(KIT)
120V 60 HZ/110V 50 HZ	H19105	K252050
24 VDC	H19112	K252051

Plug-In Style Valves

- Loosen cover screws and remove cover.
- Remove light from cover by pushing on lens. Discard light.
- Push new light into socket in housing. Be careful to align pins on bottom of light with connectors in socket.
- Reassemble cover and tighten screws to 2.3 to 2.8 Nm (20 to 25 in. lbs) torque.

JIC Valves (Without Multi-Pin Connector)

- Loosen screws and remove junction box cover.
- Snap open splice connectors and pry clip out of splice. Slide wires out of splice. Pull light out of housing and discard.
- Push new light into housing (be careful not to dislodge seal). Slide one indicator light wire into each splice. Place clip into splice and press until flush with top of splice (vice or long-handled pliers required). Snap splice housing shut. Reassemble junction box cover and tighten screws to 2.3 to 2.8 Nm (20 to 25 in. lbs) torque.

JIC Valves (with 3,4, or 5-pin connector)

NOTE: Refer to Decal placed on cover or Inside Junction Box of Pilot Operator for wiring configuration.

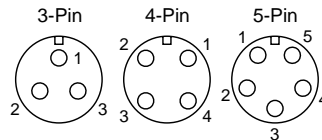

- Loosen screws and remove junction box cover.
- Unscrew wire nut from lamp leads and corresponding connector leads. Retain wire nuts.
- If lamp contains a spring clip, (24VDC) use needle nose pliers press together tangs on the spring clip holding the lamp to the cover. slide spring clip off lamp body and lamp leads.
- Gently pry up lamp and remove from cover. Discard lamp, o-ring seal, and spring clip.
- Slide new o-ring over lamp body if necessary, and reinstall lamp into cover, pressing firmly to seat.
- With needle nose pliers depress tangs on the spring clip and slip over lamp leads and down onto lamp body until firmly contacting inside of cover. Lamp should not be loose.
- If lamp does not contain a spring clip (120VAC) then pull light out of housing and discard.
- Push new light into housing (be careful not to dislodge seal).
- Reattach electrical lead wires from lamp and corresponding connector leads. Cap with wire nuts. Screw wire nuts down until all leads are secured and covered.
- Reassemble junction box cover and tighten screws to 2.3 to 2.8 Nm (20 to 25 in. lbs) torque.

For units with DC indicator lamps red wire is (+) positive white wire is (-) negative.

CAUTION: DC solenoids with indicator lamps are polarity sensitive. Observe polarities indicated above.

NOTE: In addition to the above instructions, follow all requirements for local and national electrical codes.

Manual Override Replacement

Manual overrides may be replaced or field converted. Overrides of various styles may be interchanged as long as they are of the same functional type (normally open or normally closed). (Normally closed overrides are color-coded gold).

Non-Locking Normally Open	K162001
Locking Normally Open	K152003
Extended Locking Normally Open	K152006
Non-Locking Normally Closed	K162004
Locking Normally Closed	K152005
Extended Locking Normally Closed	K152007
Spring Return Locking Override	K15020002

Remove override and clean internal threads in housing. Apply pipe sealant sparingly to threads of override housing and assemble override to pilot valve housing.

NOTE: Non-locking overrides are held out by air pressure and may not extend until pressure is reapplied to the valve.

Coil Chart

Voltage			Coil Number		
60 Hz	50 Hz	D.C.	Plug-In	19" Leads	72" Leads
12	-	-	K593052	K593007	K593178
24	-	6	K593048	K593003	K593179
-	24	-	K593061	K593015	K593181
-	-	12	K593055	K593010	K593182
-	36	-	K593062	K593016	K593183
-	-	24	K593060	K593014	K593184
-	-	48	K593074	K593028	K593185
120	110	-	K593125	K593025	K593186
240	220	-	K593081	K593035	K593187
-	230	-	K593079	-	-
-	240	-	-	K593033	K593188
-	-	90	-	K593020	K593189
-	-	115	-	K593041	K593190
-	380	-	-	K593038	K593191

NOTE: Units with multi-pin connectors should use 19" lead coils. These leads may be cut-to-length, using old coil for length measurements.



Pneumatic Division North America
 Richland, Michigan 49083

Installation & Service Instructions:
 V-644P

L-Pilot and Operators

ISSUED: September, 1999
Supersedes: March, 1999

ECN# 9115

! WARNING

To avoid unpredictable system behavior that can cause personal injury and property damage:

- Disconnect electrical supply (when necessary) before installation, servicing, or conversion.
- Disconnect air supply and depressurize all air lines connected to this product before installation, servicing, or conversion.
- Operate within the manufacturer's specified pressure, temperature, and other conditions listed in these instructions.
- Medium must be moisture-free if ambient temperature is below freezing.
- Service according to procedures listed in these instructions.
- Installation, service, and conversion of these products must be performed by knowledgeable personnel who understand how pneumatic products are to be applied.
- After installation, servicing, or conversion, air and electrical supplies (when necessary) should be connected and the product tested for proper function and leakage. If audible leakage is present, or the product does not operate properly, do not put into use.
- Warnings and specifications on the product should not be covered by paint, etc. If masking is not possible, contact your local representative for replacement labels.

Application Limits

These products are intended for use in general purpose compressed air systems only.

0 PSIG Minimum/Maximum pressures vary with model. Take the 5th through 7th digits in the model number and then look up maximum rating in the following table.

Kxxx-xxxxx < Model Number
 "C"- (Orifice / Function Code)

C	psig	bar	kPa	C	psig	bar	kPa
001	250	17.24	1724	029	150	10.34	1034
003	200	13.79	1379	033	140	9.65	965
005	150	10.34	1034	035	140	9.65	965
007	200	13.79	1379	036	150	10.34	1034
009	200	13.79	1379	037	125	8.62	862
013	200	13.79	1379	039	90	6.21	621
014	200	13.79	1379	041	60	4.14	414
015	175	12.07	1207	043	90	6.21	621
017	140	9.65	965	045	90	6.21	621
019	90	6.21	621	054	90	6.21	621
021	90	6.21	621	056	90	6.21	621
023	130	8.96	896	080	150	10.34	1034
025	140	9.65	965				

Operating Temperature Range

Minimum*: -17°C (0°F)

Maximum (Standard Service): 37°C (100°F)

Maximum (Special Service): 52°C (125°F)

* In below-freezing ambient temperatures, it is important that a suitable lubricant be reasonably moisture-free .

Voltage Range: +10% to -15% of rating.

Wiring Instructions

(Units with flying leads)

Connect the two wires to suitable supply voltage. Either may be "Hot". (Plug-in valves are merely plugged into the mating power valve or manifold base.)

! CAUTION: An interruption of 10 milliseconds or greater to the power supplied to the solenoid of a solenoid operated valve may cause the valve to shift. Provision must be made to prevent power interruption of this duration to avoid unintended, potentially hazardous, consequences.

NOTE: In addition to above instructions, follow all requirements for local and national electrical codes.

Pilot Valve Replacement

1. Loosen and remove (2) socket head capscrews and lockwashers from mounting feet.
2. Remove pilot valve and gasket.
3. Place new gasket and pilot valve on top of power valve or base, aligning edges of gasket with footprint of pilot valve.
4. Screw capscrews (with lockwashers) into power valve or base. Tighten capscrews to 4.5 to 5.6 Nm (40 to 50 in. lbs.) torque by alternatively tightening screws in progressive steps.

Service Procedures

General Service (Conduit, JIC and Plug-In Style)

1. Loosen cover screws and remove cover and top plate. Remove and discard seals from top plate and underside of cover. Replace with new seals from kit.
2. Remove split sleeve and then pull up on coil while pushing lead wires toward center of housing.
3. Remove sleeve assembly, plunger and spring. Discard plunger (retain spring). Remove and replace tetraseal in bottom of housing with new one from kit.

! WARNING

FAILURE OR IMPROPER SELECTION OR IMPROPER USE OF THE PRODUCTS AND/OR SYSTEMS DESCRIBED HEREIN OR RELATED ITEMS CAN CAUSE DEATH, PERSONAL INJURY AND PROPERTY DAMAGE.

This document and other information from Parker Hannifin Corporation, its subsidiaries and authorized distributors provide product and/or system options for further investigation by users having technical expertise. It is important that you analyze all aspects of your application, including consequences of any failure and review the information concerning the product or systems in the current product catalog. Due to the variety of operating conditions and applications for these products or systems, the user, through its own analysis and testing, is solely responsible for making the final selection of the products and systems and assuring that all performance, safety and warning requirements of the application are met.

The products described herein, including without limitation, product features, specifications, designs, availability and pricing, are subject to change by Parker Hannifin Corporation and its subsidiaries at any time without notice.

EXTRA COPIES OF THESE INSTRUCTIONS ARE AVAILABLE FOR INCLUSION IN EQUIPMENT / MAINTENANCE MANUALS THAT UTILIZE THESE PRODUCTS. CONTACT YOUR LOCAL REPRESENTATIVE.

L-Pilot Valves and Operators Indicator Light Replacement

V-644P

Indicator Lights

Volts/Hertz	Plug-In Style	JIC Style(KIT)
120V 60 HZ/110V 50 HZ	H19105	K252050
24 VDC	H19112	K252051

Plug-In Style Valves

- Loosen cover screws and remove cover.
- Remove light from cover by pushing on lens. Discard light.
- Push new light into socket in housing. Be careful to align pins on bottom of light with connectors in socket.
- Reassemble cover and tighten screws to 2.3 to 2.8 Nm (20 to 25 in. lbs) torque.

JIC Valves (Without Multi-Pin Connector)

- Loosen screws and remove junction box cover.
- Snap open splice connectors and pry clip out of splice. Slide wires out of splice. Pull light out of housing and discard.
- Push new light into housing (be careful not to dislodge seal). Slide one indicator light wire into each splice. Place clip into splice and press until flush with top of splice (vice or long-handled pliers required). Snap splice housing shut. Reassemble junction box cover and tighten screws to 2.3 to 2.8 Nm (20 to 25 in. lbs) torque.

JIC Valves (with 3,4, or 5-pin connector)

NOTE: Refer to Decal placed on cover or Inside Junction Box of Pilot Operator for wiring configuration.

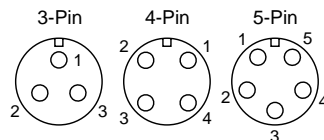

- Loosen screws and remove junction box cover.
- Unscrew wire nut from lamp leads and corresponding connector leads. Retain wire nuts.
- If lamp contains a spring clip, (24VDC) use needle nose pliers press together tangs on the spring clip holding the lamp to the cover. slide spring clip off lamp body and lamp leads.
- Gently pry up lamp and remove from cover. Discard lamp, o-ring seal, and spring clip.
- Slide new o-ring over lamp body if necessary, and reinstall lamp into cover, pressing firmly to seat.
- With needle nose pliers depress tangs on the spring clip and slip over lamp leads and down onto lamp body until firmly contacting inside of cover. Lamp should not be loose.
- If lamp does not contain a spring clip (120VAC) then pull light out of housing and discard.
- Push new light into housing (be careful not to dislodge seal).
- Reattach electrical lead wires from lamp and corresponding connector leads. Cap with wire nuts. Screw wire nuts down until all leads are secured and covered.
- Reassemble junction box cover and tighten screws to 2.3 to 2.8 Nm (20 to 25 in. lbs) torque.

For units with DC indicator lamps red wire is (+) positive white wire is (-) negative.

CAUTION: DC solenoids with indicator lamps are polarity sensitive. Observe polarities indicated above.

NOTE: In addition to the above instructions, follow all requirements for local and national electrical codes.

Manual Override Replacement

Manual overrides may be replaced or field converted. Overrides of various styles may be interchanged as long as they are of the same functional type (normally open or normally closed). (Normally closed overrides are color-coded gold).

Non-Locking Normally Open	K162001
Locking Normally Open	K152003
Extended Locking Normally Open	K152006
Non-Locking Normally Closed	K162004
Locking Normally Closed	K152005
Extended Locking Normally Closed	K152007
Spring Return Locking Override	K15020002

Remove override and clean internal threads in housing. Apply pipe sealant sparingly to threads of override housing and assemble override to pilot valve housing.

NOTE: Non-locking overrides are held out by air pressure and may not extend until pressure is reapplied to the valve.

Coil Chart

Voltage			Coil Number		
60 Hz	50 Hz	D.C.	Plug-In	19" Leads	72" Leads
12	-	-	K593052	K593007	K593178
24	-	6	K593048	K593003	K593179
-	24	-	K593061	K593015	K593181
-	-	12	K593055	K593010	K593182
-	36	-	K593062	K593016	K593183
-	-	24	K593060	K593014	K593184
-	-	48	K593074	K593028	K593185
120	110	-	K593125	K593025	K593186
240	220	-	K593081	K593035	K593187
-	230	-	K593079	-	-
-	240	-	-	K593033	K593188
-	-	90	-	K593020	K593189
-	-	115	-	K593041	K593190
-	380	-	-	K593038	K593191

NOTE: Units with multi-pin connectors should use 19" lead coils. These leads may be cut-to-length, using old coil for length measurements.



Pneumatic Division North America
8676 East M-89
Richland, MI 49083

Installation Instructions: V-648P
Time Delay Modules – K705 Series
ISSUED: November, 1998
Supersedes: K583-012, Jan., 1989
ECN #8980

INSTALLATION AND OPERATING INSTRUCTIONS FOR TIME DELAY MODULES

INSTALLATION

1. Remove pilot or remote adaptor from valve.
2. Place pilot valve gaskets (Item 1) on each side of brass plate (Item 2) and position on main valve. Align two small holes in main valve with holes in gaskets and plate. (Grease gaskets for best results.)
3. Place time delay module, open side down, on top of gaskets and plate. Position third gasket (Item 1) on top of time delay module with two small holes aligned with holes in gasket.
4. Replace pilot valve or remote adaptor on top of module and secure entire assembly using lock washers and cap screws provided. Tighten screws evenly (40-50 in.-lbs.).

SETTING DESIRED FUNCTION

1. First loosen locking screws (Item 6) about $\frac{1}{4}$ turn. If delay of valve action is desired after application of signal, set pointer on selector plate (Item 5) to "On-Delay". (Use pointer marked "Elect" when time delay module is used on solenoid-operated valve. Use pointer marked "Air" when time delay module is used with remote adaptor and normally closed remote pilot signal.)
2. To delay valve action after removal of signal, set pointer to "Off-Delay".
3. When pointer is set at "On-Off-Delay", valve action will be delayed after both application and removal of signal.
4. Be sure to lock the selector plate by retightening the two locking screws.

OPERATION

1. Check length of time delay by cycling valve with pilot and main valve supply set at desired operating pressures. If a longer delay is required, turn the metering screw (Item 7) in. To shorten delay, turn metering screw out.
2. To get accurate and repeatable timing cycles, the following conditions should be met:
 - (A) Use filtered air to the pilot valve or remote adaptor.
 - (B) All external leakage should be eliminated.
 - (C) Screws holding selector plate should be tight.
2. If extended time delay is required, remove the $\frac{1}{4}$ " N.P.T.F. pipe plug (Item 8) and pipe a small reservoir to the $\frac{1}{4}$ " N.P.T.F. port provided. A 2" long piece of $\frac{1}{4}$ " pipe installed in this port, with end capped, will approximately double the time range of the time delay module.

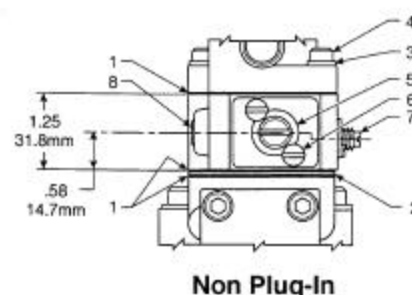
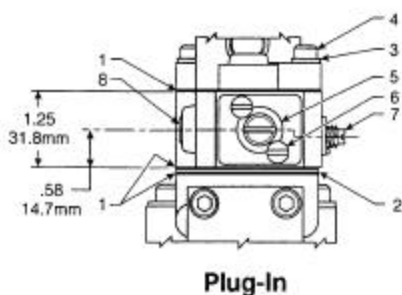



Pneumatic Division
Richland, Michigan 49083
269-629-5000

PDNSG-1

Pneumatic Division Safety Guide

ISSUED: August 1, 2006

Supersedes: June 1, 2006

Safety Guide For Selecting And Using Pneumatic Division Products And Related Accessories

⚠ WARNING:

FAILURE OR IMPROPER SELECTION OR IMPROPER USE OF PNEUMATIC DIVISION PRODUCTS, ASSEMBLIES OR RELATED ITEMS ("PRODUCTS") CAN CAUSE DEATH, PERSONAL INJURY, AND PROPERTY DAMAGE. POSSIBLE CONSEQUENCES OF FAILURE OR IMPROPER SELECTION OR IMPROPER USE OF THESE PRODUCTS INCLUDE BUT ARE NOT LIMITED TO:

- Unintended or mistimed cycling or motion of machine members or failure to cycle
- Work pieces or component parts being thrown off at high speeds.
- Failure of a device to function properly for example, failure to clamp or unclamp an associated item or device.
- Explosion
- Suddenly moving or falling objects.
- Release of toxic or otherwise injurious liquids or gasses.

Before selecting or using any of these Products, it is important that you read and follow the instructions below.

1. GENERAL INSTRUCTIONS

- 1.1. Scope:** This safety guide is designed to cover general guidelines on the installation, use, and maintenance of Pneumatic Division Valves, FRLs (Filters, Pressure Regulators, and Lubricators), Vacuum products and related accessory components.
- 1.2. Fail-Safe:** Valves, FRLs, Vacuum products and their related components can and do fail without warning for many reasons. Design all systems and equipment in a fail-safe mode, so that failure of associated valves, FRLs or Vacuum products will not endanger persons or property.
- 1.3. Relevant International Standards:** For a good guide to the application of a broad spectrum of pneumatic fluid power devices see: ISO 4414:1998, Pneumatic Fluid Power – General Rules Relating to Systems. See www.iso.org for ordering information.
- 1.4. Distribution:** Provide a copy of this safety guide to each person that is responsible for selection, installation, or use of Valves, FRLs or Vacuum products. Do not select, or use Parker valves, FRLs or vacuum products without thoroughly reading and understanding this safety guide as well as the specific Parker publications for the products considered or selected.
- 1.5. User Responsibility:** Due to the wide variety of operating conditions and applications for valves, FRLs, and vacuum products Parker and its distributors do not represent or warrant that any particular valve, FRL or vacuum product is suitable for any specific end use system. This safety guide does not analyze all technical parameters that must be considered in selecting a product. The user, through its own analysis and testing, is solely responsible for:
 - Making the final selection of the appropriate valve, FRL, Vacuum component, or accessory.
 - Assuring that all user's performance, endurance, maintenance, safety, and warning requirements are met and that the application presents no health or safety hazards.
 - Complying with all existing warning labels and / or providing all appropriate health and safety warnings on the equipment on which the valves, FRLs or Vacuum products are used; and,
 - Assuring compliance with all applicable government and industry standards.
- 1.6. Safety Devices:** Safety devices should not be removed, or defeated.
- 1.7. Warning Labels:** Warning labels should not be removed, painted over or otherwise obscured.
- 1.8. Additional Questions:** Call the appropriate Parker technical service department if you have any questions or require any additional information. See the Parker publication for the product being considered or used, or call 1-800-CPARKER, or go to www.parker.com, for telephone numbers of the appropriate technical service department.

2. PRODUCT SELECTION INSTRUCTIONS

- 2.1. Flow Rate:** The flow rate requirements of a system are frequently the primary consideration when designing any pneumatic system. System components need to be able to provide adequate flow and pressure for the desired application.
- 2.2. Pressure Rating:** Never exceed the rated pressure of a product. Consult product labeling, Pneumatic Division catalogs or the instruction sheets supplied for maximum pressure ratings.
- 2.3. Temperature Rating:** Never exceed the temperature rating of a product. Excessive heat can shorten the life expectancy of a product and result in complete product failure.
- 2.4. Environment:** Many environmental conditions can affect the integrity and suitability of a product for a given application. Pneumatic Division products are designed for use in general purpose industrial applications. If these products are to be used in unusual circumstances such as direct sunlight and/or corrosive or caustic environments, such use can shorten the useful life and lead to premature failure of a product.
- 2.5. Lubrication and Compressor Carryover:** Some modern synthetic oils can and will attack nitrile seals. If there is any possibility of synthetic oils or greases migrating into the pneumatic components check for compatibility with the seal materials used. Consult the factory or product literature for materials of construction.
- 2.6. Polycarbonate Bowls and Sight Glasses:** To avoid potential polycarbonate bowl failures:
 - Do not locate polycarbonate bowls or sight glasses in areas where they could be subject to direct sunlight, impact blow, or temperatures outside of the rated range.
 - Do not expose or clean polycarbonate bowls with detergents, chlorinated hydro-carbons, ketones, esters or certain alcohols.
 - Do not use polycarbonate bowls or sight glasses in air systems where compressors are lubricated with fire resistant fluids such as phosphate ester and di-ester lubricants.

Pneumatic Division Safety Guide

- 2.7. Chemical Compatibility:** For more information on plastic component chemical compatibility see Pneumatic Division technical bulletins Tec-3, Tec-4, and Tec-5
- 2.8. Product Rupture:** Product rupture can cause death, serious personal injury, and property damage.
- Do not connect pressure regulators or other Pneumatic Division products to bottled gas cylinders.
 - Do not exceed the maximum primary pressure rating of any pressure regulator or any system component.
 - Consult product labeling or product literature for pressure rating limitations.

3. PRODUCT ASSEMBLY AND INSTALLATION INSTRUCTIONS

- 3.1. Component Inspection:** Prior to assembly or installation a careful examination of the valves, FRLs or vacuum products must be performed. All components must be checked for correct style, size, and catalog number. DO NOT use any component that displays any signs of nonconformance.
- 3.2. Installation Instructions:** Parker published Installation Instructions must be followed for installation of Parker valves, FRLs and vacuum components. These instructions are provided with every Parker valve or FRL sold, or by calling 1-800-CPARKER, or at www.parker.com.
- 3.3. Air Supply:** The air supply or control medium supplied to Valves, FRLs and Vacuum components must be moisture-free if ambient temperature can drop below freezing

4. VALVE AND FRL MAINTENANCE AND REPLACEMENT INSTRUCTIONS

- 4.1. Maintenance:** Even with proper selection and installation, valve, FRL and vacuum products service life may be significantly reduced without a continuing maintenance program. The severity of the application, risk potential from a component failure, and experience with any known failures in the application or in similar applications should determine the frequency of inspections and the servicing or replacement of Pneumatic Division products so that products are replaced before any failure occurs. A maintenance program must be established and followed by the user and, at minimum, must include instructions 4.2 through 4.10.
- 4.2. Installation and Service Instructions:** Before attempting to service or replace any worn or damaged parts consult the appropriate Service Bulletin for the valve or FRL in question for the appropriate practices to service the unit in question. These Service and Installation Instructions are provided with every Parker valve and FRL sold, or are available by calling 1-800-CPARKER, or by accessing the Parker web site at www.parker.com.
- 4.3. Lockout / Tagout Procedures:** Be sure to follow all required lockout and tagout procedures when servicing equipment. For more information see: OSHA Standard – 29 CFR, Part 1910.147, Appendix A, The Control of Hazardous Energy – (Lockout / Tagout)
- 4.4. Visual Inspection:** Any of the following conditions requires immediate system shut down and replacement of worn or damaged components:
- Air leakage: Look and listen to see if there are any signs of visual damage to any of the components in the system. Leakage is an indication of worn or damaged components.
 - Damaged or degraded components: Look to see if there are any visible signs of wear or component degradation.
 - Kinked, crushed, or damaged hoses. Kinked hoses can result in restricted air flow and lead to unpredictable system behavior.
 - Any observed improper system or component function: Immediately shut down the system and correct malfunction.
 - Excessive dirt build-up: Dirt and clutter can mask potentially hazardous situations.

Caution: Leak detection solutions should be rinsed off after use.

- 4.5. Routine Maintenance Issues:**
- Remove excessive dirt, grime and clutter from work areas.
 - Make sure all required guards and shields are in place.
- 4.6. Functional Test:** Before initiating automatic operation, operate the system manually to make sure all required functions operate properly and safely.
- 4.7. Service or Replacement Intervals:** It is the user's responsibility to establish appropriate service intervals. Valves, FRLs and vacuum products contain components that age, harden, wear, and otherwise deteriorate over time. Environmental conditions can significantly accelerate this process. Valves, FRLs and vacuum components need to be serviced or replaced on routine intervals. Service intervals need to be established based on:
- Previous performance experiences.
 - Government and / or industrial standards.
 - When failures could result in unacceptable down time, equipment damage or personal injury risk.
- 4.8. Servicing or Replacing of any Worn or Damaged Parts:** To avoid unpredictable system behavior that can cause death, personal injury and property damage:
- Follow all government, state and local safety and servicing practices prior to service including but not limited to all OSHA Lockout Tagout procedures (OSHA Standard – 29 CFR, Part 1910.147, Appendix A, The Control of Hazardous Energy – Lockout / Tagout).
 - Disconnect electrical supply (when necessary) before installation, servicing, or conversion.
 - Disconnect air supply and depressurize all air lines connected to system and Pneumatic Division products before installation, service, or conversion.
 - Installation, servicing, and / or conversion of these products must be performed by knowledgeable personnel who understand how pneumatic products are to be applied.
 - After installation, servicing, or conversions air and electrical supplies (when necessary) should be connected and the product tested for proper function and leakage. If audible leakage is present, or if the product does not operate properly, do not put product or system into use.
 - Warnings and specifications on the product should not be covered or painted over. If masking is not possible, contact your local representative for replacement labels.
- 4.9. Putting Serviced System Back into Operation:** Follow the guidelines above and all relevant Installation and Maintenance Instructions supplied with the valve FRL or vacuum component to insure proper function of the system.