

# LSG, LGV, LGH-SERIES

Stainless Steel Pump Stand

# Liberty Pumps®

A Family and Employee Owned Company

## Part # K002012

- Stainless steel pump stand fits all 2hp LSG, LSGX, and 2.5hp LGV, LGH-Series grinder pumps
- Elevates grinder pump 4.9" off the bottom of the pit
- Helps reduce sediment or abrasives from entering the pump
- Made from 316 stainless steel
- Kit includes: stainless steel mounting hardware

## Dimensional Data

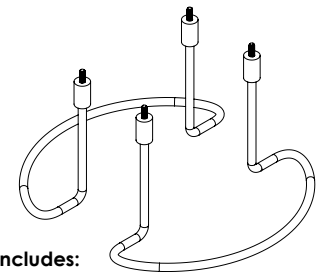
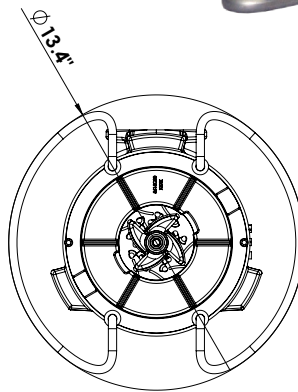
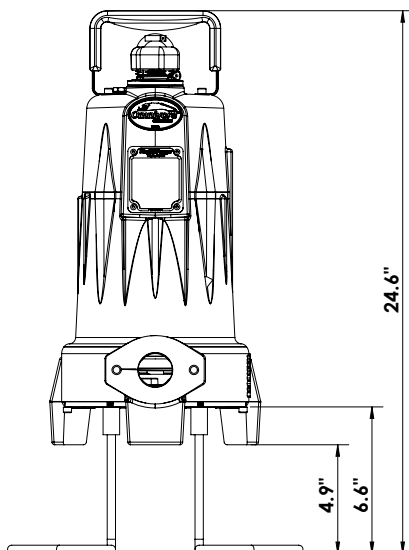

Kit Includes:

- 2X 3850000 STAND
- 4X 3775000 BUSHING
- 4X 1/4-20 SHCS, 18-8SS 7/8"
- 4X 10-32 CPSS, 18-8SS 3/16"

Specifications subject to change without notice.

Copyright © Liberty Pumps, Inc. 2023 All rights reserved. LLIT006832-R05/23

Liberty Pumps - 7000 Apple Tree Avenue - Bergen, New York 14416  
Phone 800-543-2550 - Fax 585-494-1839 - LibertyPumps.com